

D3FJ10

100V 3A

特長

- 小型SMD
- 低 $I_R=0.4\text{mA}$
- 熱暴走を起こしにくい

Feature

- Small SMD
- Low $I_R=0.4\text{mA}$
- Resistance for thermal run-away

用途

- スイッチング電源
- DC/DC コンバータ
- 家電、ゲーム、OA 機器
- 通信、ポータブル機器

Main Use

- Switching Regulator
- DC/DC Converter
- Home Appliance, Game, Office Automation
- Communication, Portable set

■外観図 OUTLINE

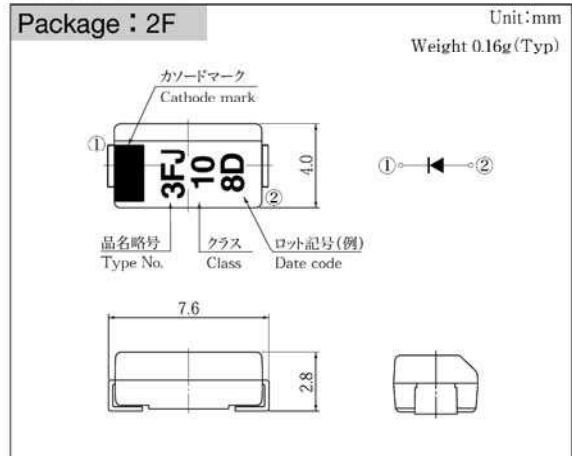

外形図については新電元Webサイト又は〈半導体製品一覧表〉をご参照下さい。捺印表示については捺印仕様をご確認下さい。

For details of the outline dimensions, refer to our web site or Semiconductor Short Form Catalog. As for the marking, refer to the specification "Marking, Terminal Connection".

■定格表 RATINGS

●絶対最大定格 Absolute Maximum Ratings (指定のない場合 $T_I=25^\circ\text{C}$)

項目 Item	記号 Symbol	条件 Conditions	品名 Type No.	D3FJ10	単位 Unit
保存温度 Storage Temperature	T_{stg}			-55~150	$^\circ\text{C}$
接合部温度 Operation Junction Temperature	T_j			150	$^\circ\text{C}$
せん頭逆電圧 Maximum Reverse Voltage	V_{RM}			100	V
出力電流 Average Rectified Forward Current	I_o	50Hz正弦波, 抵抗負荷 50Hz sine wave, Resistance load	$T_a=30^\circ\text{C}$ プリント基板実装 On glass-epoxy substrate	1.4	A
			$T_a=28^\circ\text{C}$ アルミナ基板実装 On alumina substrate	2.0	
			$T_I=92^\circ\text{C}$	3.0	
せん頭サージ順電流 Peak Surge Forward Current	I_{FSM}	50Hz正弦波, 非繰り返し1サイクルせん頭値, $T_j=25^\circ\text{C}$ 50Hz sine wave, Non-repetitive 1 cycle peak value, $T_j=25^\circ\text{C}$		100	A

●電氣的・熱的特性 Electrical Characteristics (指定のない場合 $T_I=25^\circ\text{C}$)

順電圧 Forward Voltage	V_F	$I_F=3.0\text{A}$, パルス測定 Pulse measurement		MAX 0.74	V
逆電流 Reverse Current	I_R	$V_R=V_{RM}$, パルス測定 Pulse measurement		MAX 0.4	mA
接合容量 Junction Capacitance	C_j	$f=1\text{MHz}$, $V_R=10\text{V}$		TYP 143	pF
熱抵抗 Thermal Resistance	θ_{jI}	接合部・リード間 Junction to lead		MAX 23	$^\circ\text{C/W}$
	θ_{ja}	接合部・周囲間 Junction to ambient	プリント基板実装 On glass-epoxy substrate アルミナ基板実装 On alumina substrate	MAX 115 MAX 80	

■特性図 CHARACTERISTIC DIAGRAMS

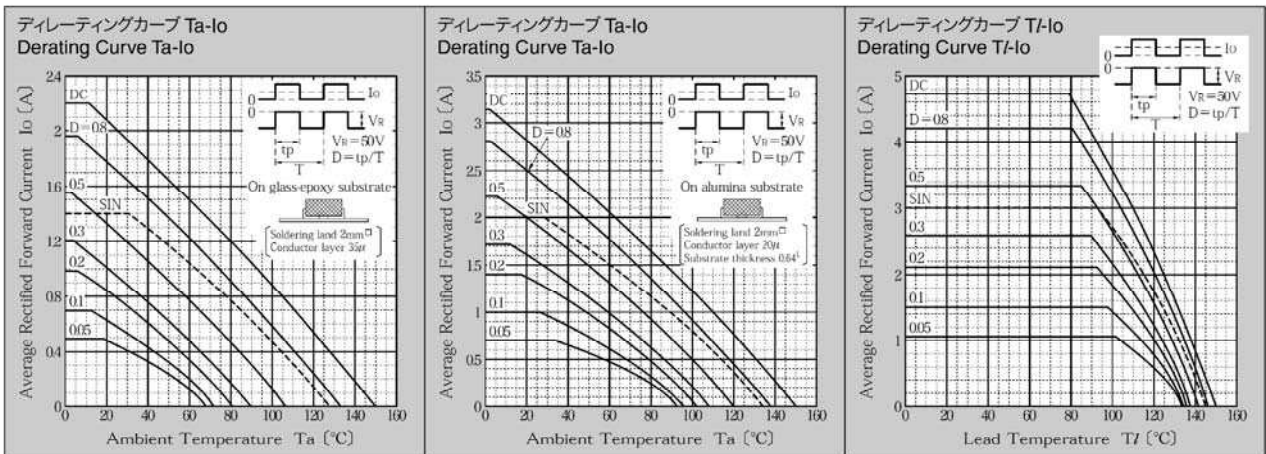
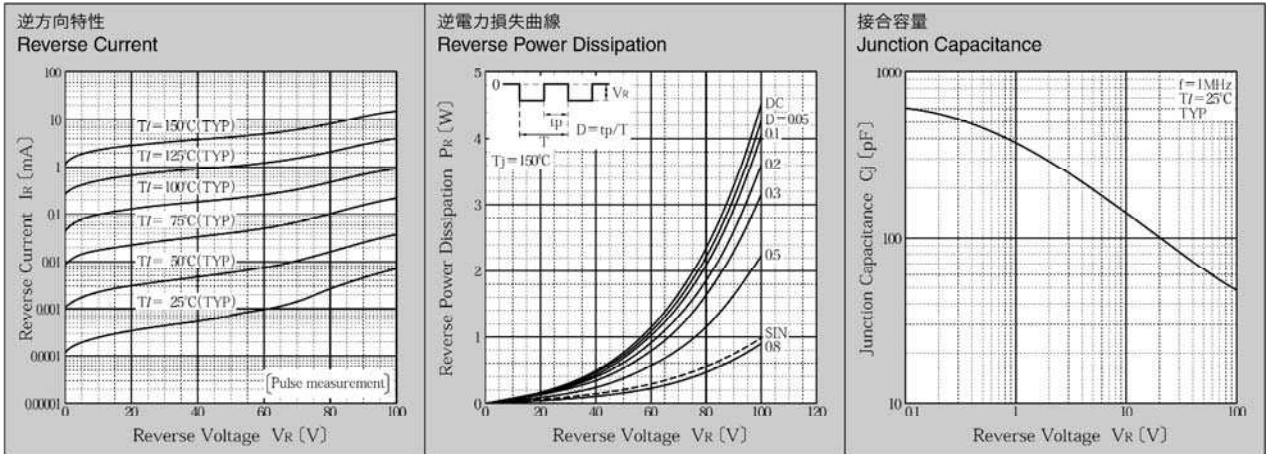
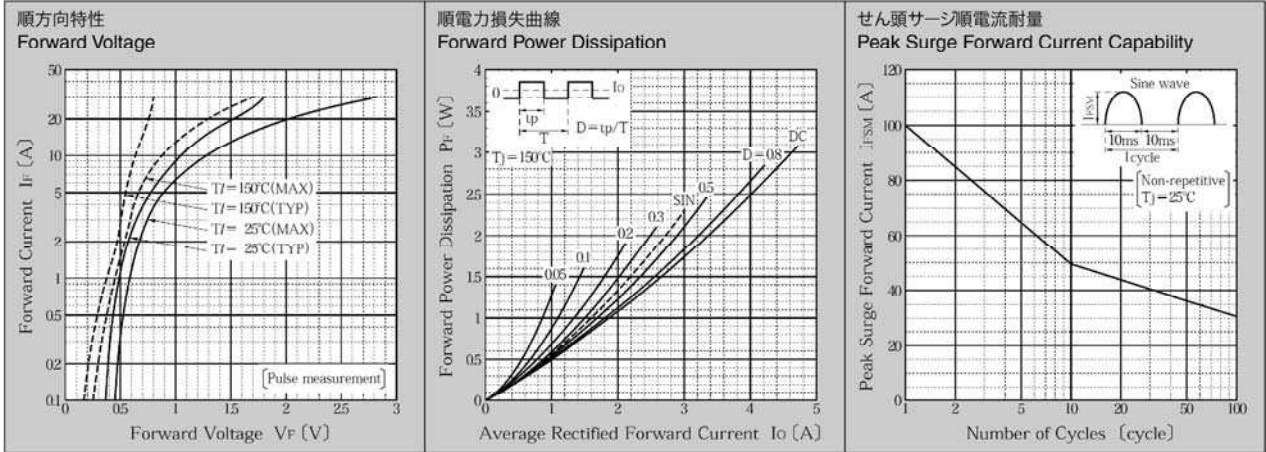

* Sine waveは50Hzで測定しています。
 * 50Hz sine wave is used for measurements.
 * 半導体製品の特性は一般的にバラツキを持っています。
 Typical is a statistical average of the device's ability.
 * Semiconductor products generally have characteristic variation.
 Typical is a statistical average of the device's ability.