

SF8L60USM

600V 8A

特長

- 低ノイズ
- $t_{rr}=25\text{ns}$
- フルモールド
- 絶縁耐圧 2kV保証

Feature

- Low Noise
- $t_{rr}=25\text{ns}$
- Full Molded
- Dielectric Strength 2kV

用途

- スイッチング電源
- 家電、OA
- 通信
- フライホール

Main Use

- Switching Regulator
- Home Appliance, Office Automation
- Communication
- Fly Wheel

■外観図 OUTLINE

Package : FTO-220A

Unit:mm

Weight 1.9g (Typ)

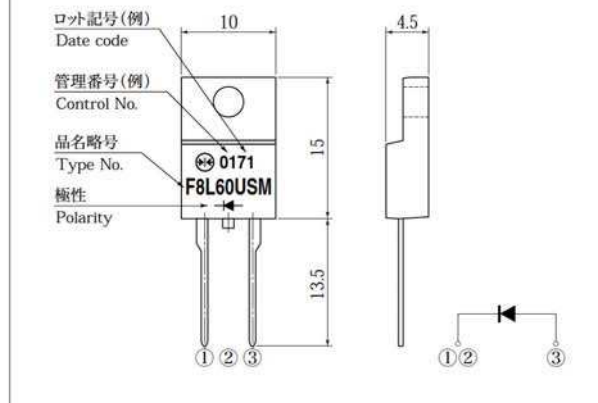

外形図については新電元Webサイトをご参照下さい。捺印表示については捺印仕様をご確認下さい。

For details of the outline dimensions, refer to our web site. As for the marking, refer to the specification "Marking, Terminal Connection".

■定格表 RATINGS

●絶対最大定格 Absolute Maximum Ratings (指定のない場合 $T_c = 25^\circ\text{C}$)

項目 Item	記号 Symbol	条件 Conditions	品名 Type No.	SF8L60USM	単位 Unit
保存温度 Storage Temperature	T_{stg}			-55~150	$^\circ\text{C}$
接合部温度 Operation Junction Temperature	T_j			150	$^\circ\text{C}$
せん頭逆電圧 Maximum Reverse Voltage	V_{RM}			600	V
最大順電流 Repetitive Peak Forward Current	I_{FM}	50Hz 正弦波, 抵抗負荷, $T_c = 58^\circ\text{C}$, フィン付き 50Hz sine wave, Resistance load, $T_c = 58^\circ\text{C}$, With heatsink		25	A
出力電流 Average Rectified Forward Current	I_o	50Hz 正弦波, 抵抗負荷, $T_c = 58^\circ\text{C}$, フィン付き 50Hz sine wave, Resistance load, $T_c = 58^\circ\text{C}$, With heatsink		8	A
せん頭サーージ順電流 Peak Surge Forward Current	I_{FSM}	50Hz 正弦波, 非繰り返し1サイクルせん頭値, $T_j = 25^\circ\text{C}$ 50Hz sine wave, Non-repetitive 1 cycle peak value, $T_j = 25^\circ\text{C}$		60	A
絶縁耐圧 Dielectric Strength	V_{dis}	一括端子・ケース間, AC 1分間印加 Terminals to case, AC 1 minute		2.0	kV
締め付けトルク Mounting Torque	TOR	(推奨値: $0.3\text{N}\cdot\text{m}$) (Recommended torque: $0.3\text{N}\cdot\text{m}$)		0.5	$\text{N}\cdot\text{m}$

●電氣的・熱的特性 Electrical Characteristics (指定のない場合 $T_c = 25^\circ\text{C}$)

項目 Item	記号 Symbol	条件 Conditions	品名 Type No.	SF8L60USM	単位 Unit
順電圧 Forward Voltage	V_F	$I_F = 8\text{A}$, パルス測定 Pulse measurement		MAX 3.6	V
逆電流 Reverse Current	I_R	$V_R = 600\text{V}$, パルス測定 Pulse measurement		MAX 50	μA
逆回復時間 Reverse Recovery Time	t_{rr}	$I_F = 0.5\text{A}$, $I_R = 1.0\text{A}$		MAX 25	ns
接合容量 Junction Capacitance	C_j	$f = 1\text{MHz}$, $V_R = 10\text{V}$		TYP 24	pF
熱抵抗 Thermal Resistance	θ_{jc}	接合部・ケース間 Junction to case		MAX 2.5	$^\circ\text{C}/\text{W}$

Two Terminal Type

■特性図 CHARACTERISTIC DIAGRAMS

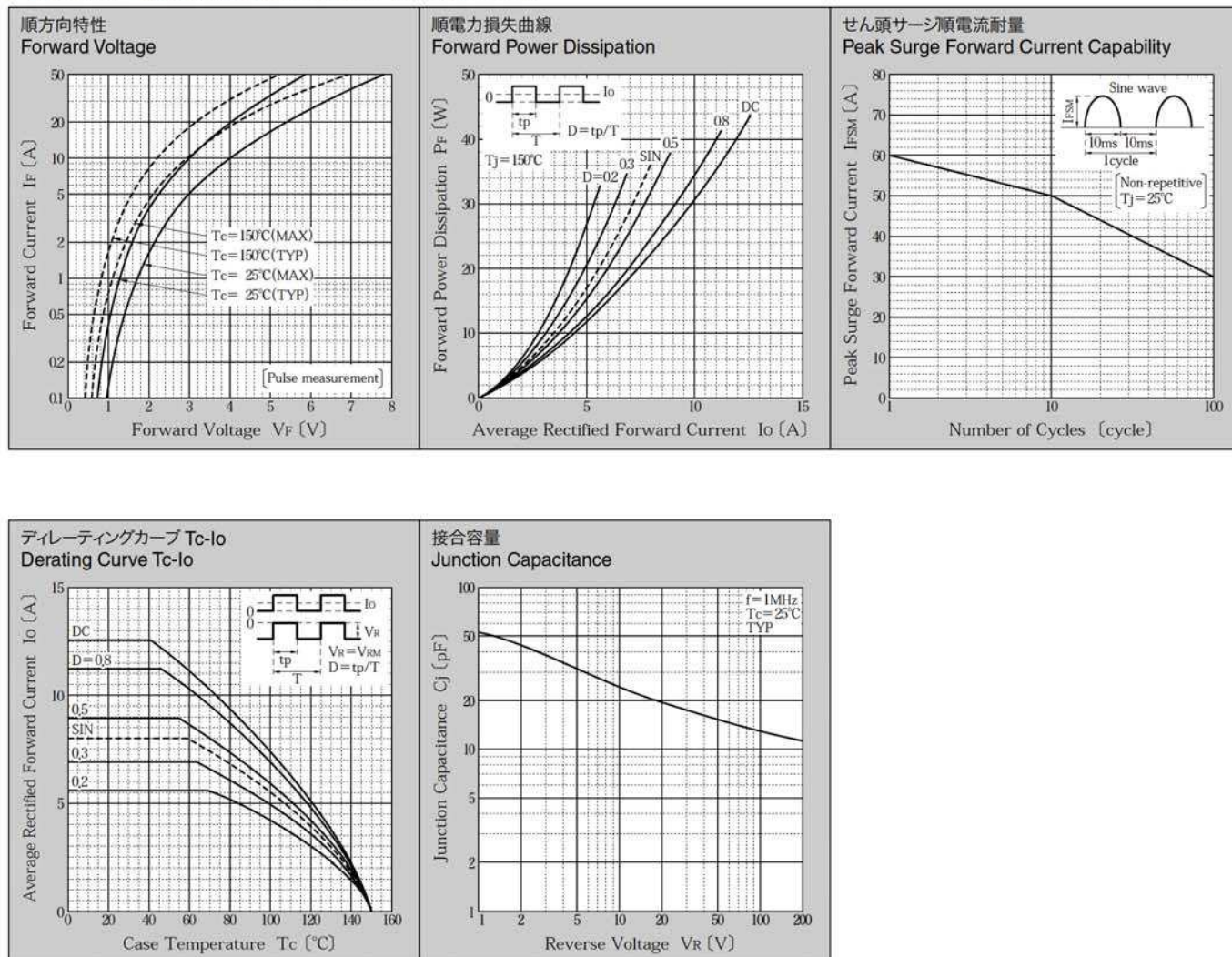

* Sine waveは50Hzで測定しています。
* 50Hz sine wave is used for measurements.
* 半導体製品の特性は一般的にバラツキを持っています。
* Typicalは統計的な実力を表しています。
* Semiconductor products generally have characteristic variation.
* Typical is a statistical average of the device's ability.