

Power MOSFET

F16F60CPM

600V 16A

特長

- 高耐圧
- 低オン抵抗
- 高速スイッチング

Feature

- High Voltage
- Low R_{ON}
- Fast Switching

■ 外観図 OUTLINE

Package : FTO-220A (3pin)

Unit : mm

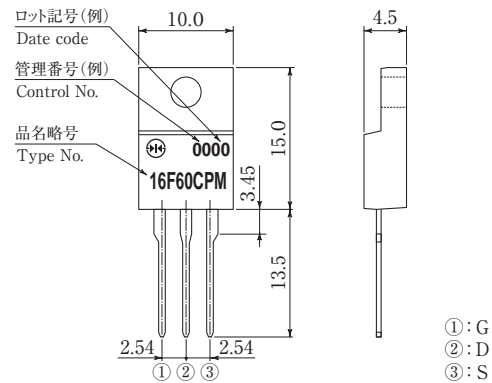

外形図については新電元 Web サイトをご参照下さい。捺印表示については捺印仕様をご確認下さい。

For details of the outline dimensions, refer to our web site. As for the marking, refer to the specification "Marking, Terminal Connection".

■ 定格表 RATINGS

● 絶対最大定格 Absolute Maximum Ratings (指定のない場合 $T_c = 25^\circ\text{C}$ / unless otherwise specified)

項目 Item	記号 Symbol	条件 Conditions	規格値 Ratings	単位 Unit
保存温度 Storage Temperature	Tstg		-55 ~ 150	°C
チャネル温度 Channel Temperature	Tch		150	
ドレイン・ソース間電圧 Drain-Source Voltage	V_{DSS}		600	V
ゲート・ソース間電圧 Gate-Source Voltage	V_{GSS}		±30	
ドレイン電流 (直流) Continuous Drain Current (DC)	I_D		16	A
ドレイン電流 (ピーク) Continuous Drain Current (Peak)	I_{DP}	パルス幅 10 μs , duty=1/100 Pulse width 10 μs , duty=1/100	48	
ソース電流 (直流) Continuous Source Current (DC)	I_S		16	
全損失 Total Power Dissipation	P_T		55	W
絶縁耐圧 Dielectric Strength	Vdis	一括端子・ケース間, AC 1 分間印加 Terminals to case, AC 1 minute	2	kV
締め付けトルク Mounting Torque	TOR	(推奨値: 0.3N·m) (Recommended torque: 0.3N·m)	0.5	N·m

● 電氣的・熱的特性 Electrical Characteristics (指定のない場合 $T_c = 25^\circ\text{C}$ / unless otherwise specified)

項目 Item	記号 Symbol	条件 Conditions	規格値 Ratings			単位 Unit
			MIN	TYP	MAX	
ドレイン・ソース間降伏電圧 Drain-Source Breakdown Voltage	$V_{(BR)DSS}$	$I_D = 1\text{mA}$, $V_{GS} = 0\text{V}$	600	—	—	V
ドレイン遮断電流 Zero Gate Voltage Drain Current	I_{DSS}	$V_{DS} = 600\text{V}$, $V_{GS} = 0\text{V}$	—	—	10	μA
ゲート漏れ電流 Gate-Source Leakage Current	I_{GSS}	$V_{GS} = \pm 30\text{V}$, $V_{DS} = 0\text{V}$	—	—	±0.1	μA
順伝達コンダクタンス Forward Transconductance	gfs	$I_D = 8\text{A}$, $V_{DS} = 10\text{V}$	7	14	—	S
ドレイン・ソース間オン抵抗 Static Drain-Source On-state Resistance	$R_{(DS)ON}$	$I_D = 8\text{A}$, $V_{GS} = 10\text{V}$	—	0.180	0.199	Ω
ゲートしきい値電圧 Gate Threshold Voltage	V_{TH}	$I_D = 1\text{mA}$, $V_{DS} = 10\text{V}$	2.5	3.0	3.5	V
ソース・ドレイン間ダイオード順電圧 Source-Drain Diode Forward Voltage	V_{SD}	$I_S = 8\text{A}$, $V_{GS} = 0\text{V}$	—	—	1.5	V
熱抵抗 Thermal Resistance	θ_{jc}	接合部・ケース間 Junction to case	—	—	2.27	°C/W
ゲート全電荷量 Total Gate Charge	Qg	$V_{DD} = 400\text{V}$, $V_{GS} = 10\text{V}$, $I_D = 16\text{A}$	—	33	—	nC
入力容量 Input Capacitance	Ciss	$V_{DS} = 100\text{V}$, $V_{GS} = 0\text{V}$, $f = 1\text{MHz}$	—	1520	—	pF
掃還容量 Reverse Transfer Capacitance	Crss		—	2.5	—	
出力容量 Output Capacitance	Coss		—	72	—	
ターンオン遅延時間 Turn-on delay time	td(on)	$I_D = 8\text{A}$, $R_L = 18.75\Omega$, $V_{DD} = 150\text{V}$, $R_g = 50\Omega$, $V_{GS(+)} = 10\text{V}$, $V_{GS(-)} = 0\text{V}$	—	30	—	ns
上昇時間 Rise time	tr		—	45	—	
ターンオフ遅延時間 Turn-off delay time	td(off)		—	125	—	
降下時間 Fall time	tf		—	40	—	

■特性図 CHARACTERISTIC DIAGRAMS

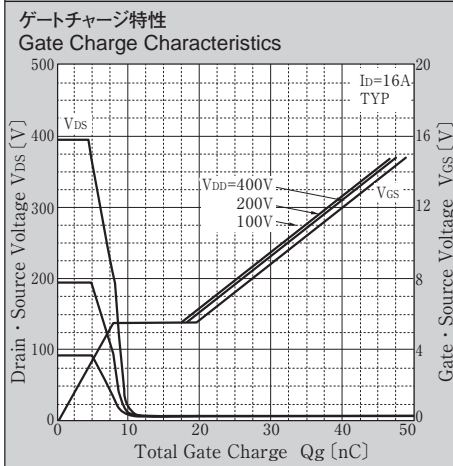
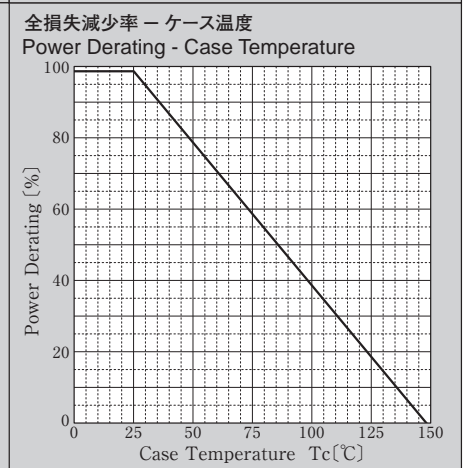
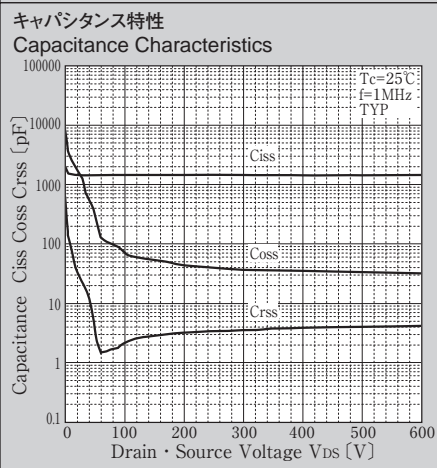
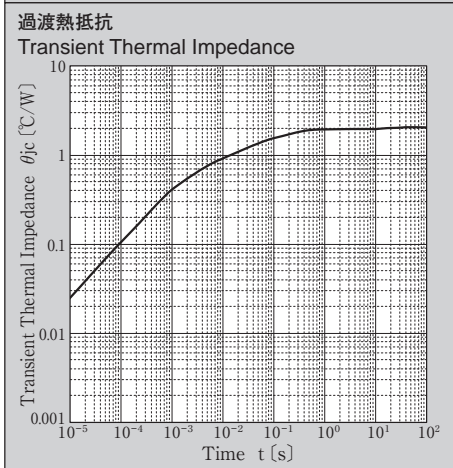
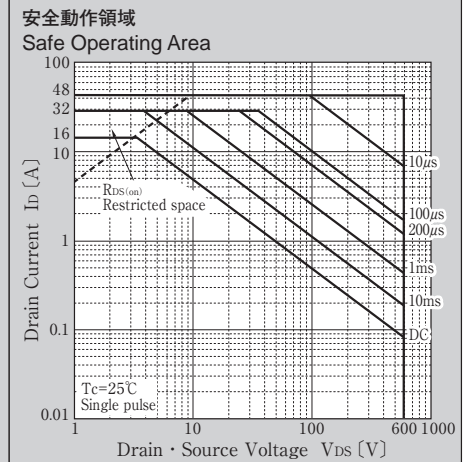
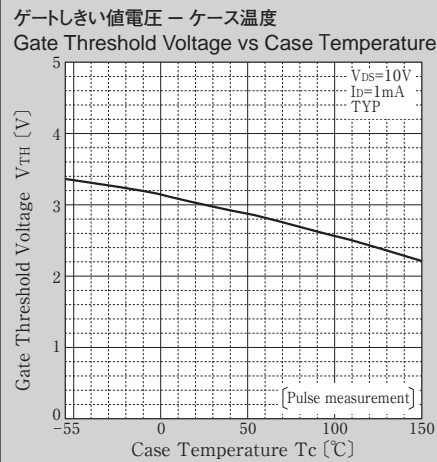
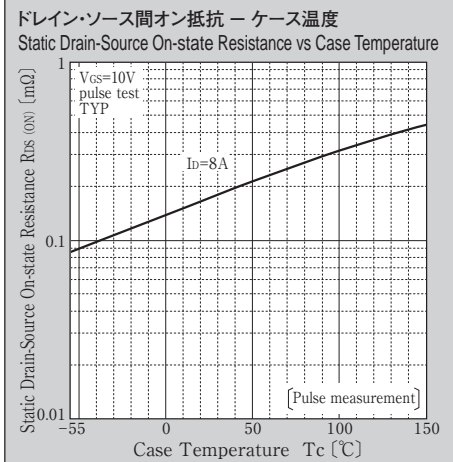
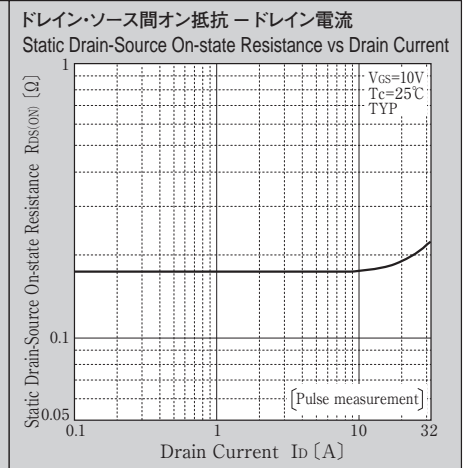
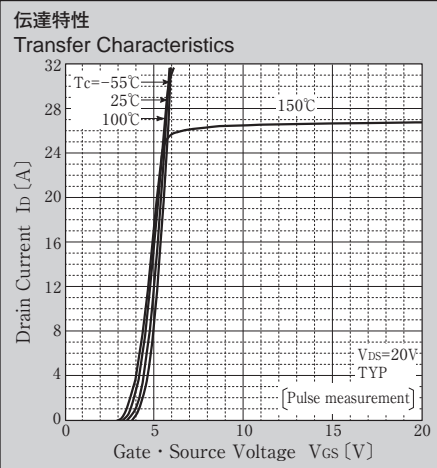
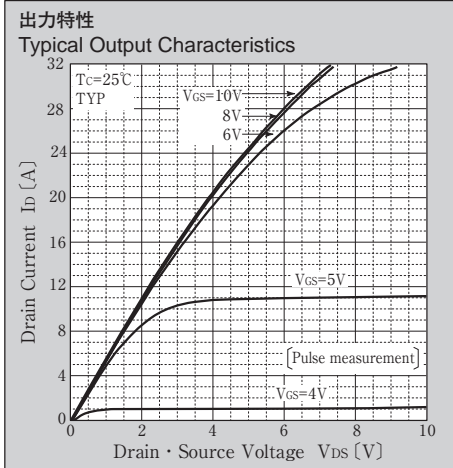

* Sine wave は 50Hz で測定しています。
* 50Hz sine wave is used for measurements.