

ST20-27F2

27V 2000W

特長

- 3W クラス
- SMD
- 車載用途も対応可能

Feature

- 3W Class
- SMD
- Available for automotive

外観図 OUTLINE

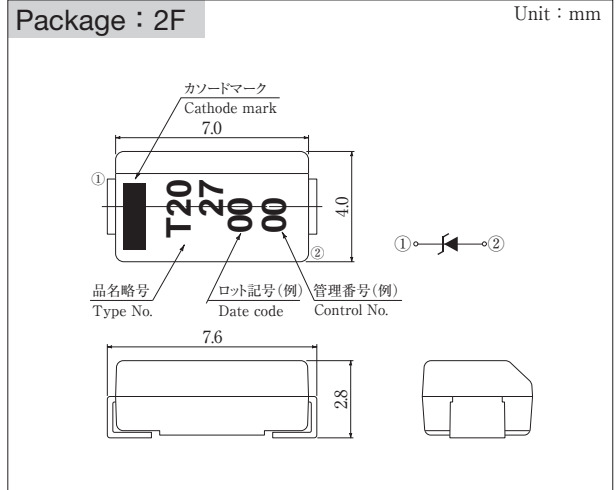

外形図については新電元 Web サイトをご参照下さい。捺印表示については捺印仕様をご確認下さい。
For details of the outline dimensions, refer to our web site. As for the marking, refer to the specification "Marking, Terminal Connection".

定格表 RATINGS

●絶対最大定格 Absolute Maximum Ratings (指定のない場合 $T_l = 25^\circ\text{C}$ / unless otherwise specified)

項目 Item	記号 Symbol	条件 Conditions	規格値 Ratings	単位 Unit
保存温度 Storage Temperature	T_{stg}		- 55 ~ 175	$^\circ\text{C}$
接合部温度 Operation Junction Temperature	T_j		175	$^\circ\text{C}$
せん頭サージ逆電流 Maximum Surge Reverse Current	I_{RSM}	10/1000 μs 非繰り返し 10/1000 μs Non-repetitive	54	A
せん頭サージ逆電力 Maximum Surge Reverse Power	P_{RSM}	10/1000 μs 非繰り返し 10/1000 μs Non-repetitive	2000	W
連続印加電圧 Maximum Reverse Voltage	V_{RM}		23	V

●電気的・熱的特性 Electrical Characteristics (指定のない場合 $T_l = 25^\circ\text{C}$ / unless otherwise specified)

動作開始電圧 Movement Start Voltage	V_{BR}	$I_R = 1\text{mA}$	MIN 24.3 TYP 27.0 MAX 29.7	V
制限電圧 Clamping Voltage	V_{CL}	10/1000 μs , $I_{pp} = 54\text{A}$	MAX 37	V
漏れ電流 Leakage Current	I_R	$V_R = 23\text{V}$, パルス測定 Pulse measurement	MAX 5.0	μA
熱抵抗 Thermal Resistance	θ_{jl}	接合部・リード間, プリント基板実装 Junction to lead, On glass-epoxy substrate	MAX 23	$^\circ\text{C}/\text{W}$
	θ_{ja}	接合部・周囲間, プリント基板実装 Junction to ambient, On glass-epoxy substrate	MAX 115	
温度係数 Temperature Coefficient	r_z		MAX 0.12	$\% / ^\circ\text{C}$

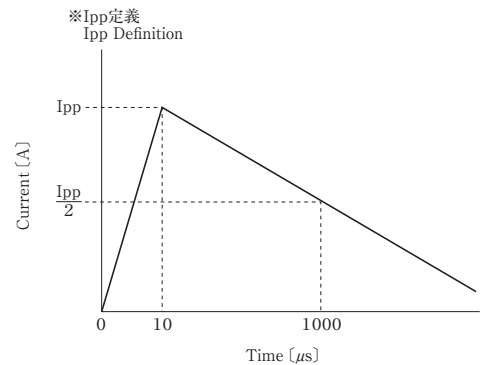

■特性図 CHARACTERISTIC DIAGRAMS

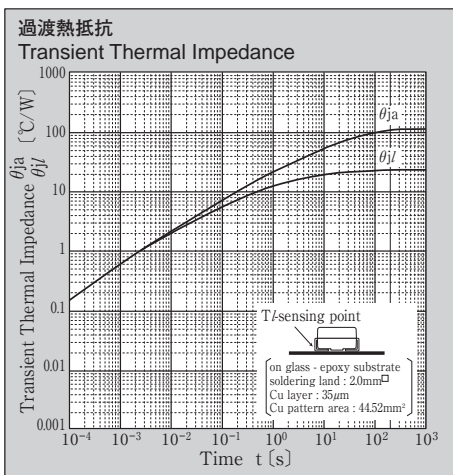
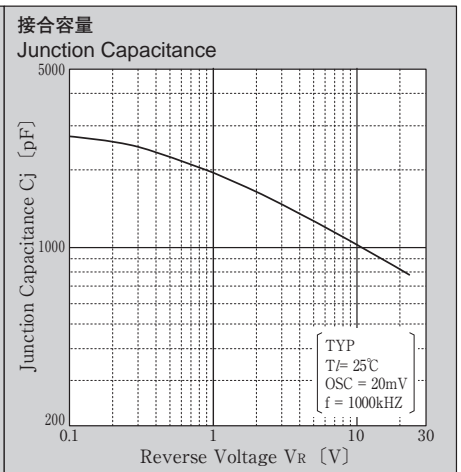
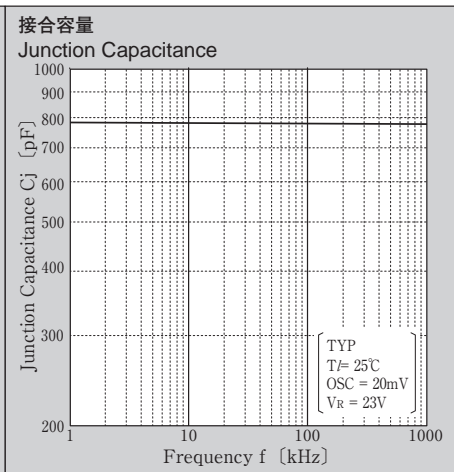
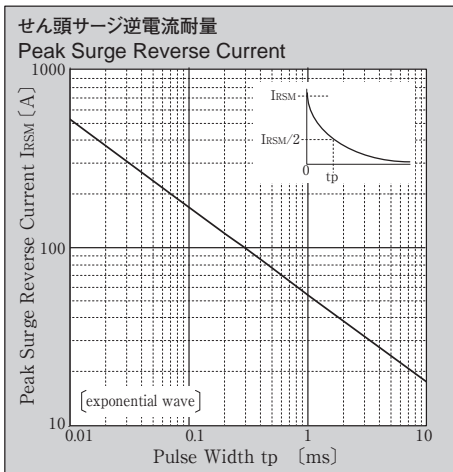
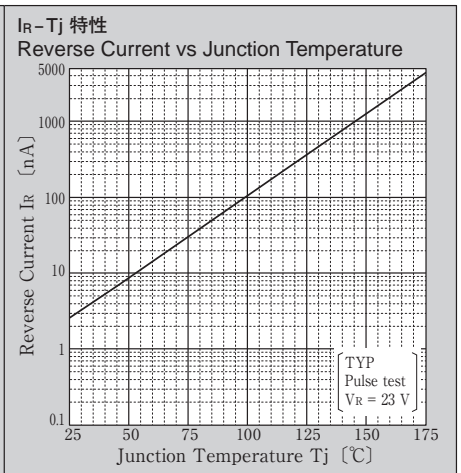
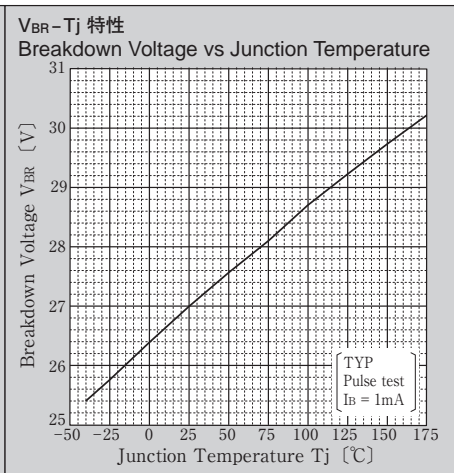
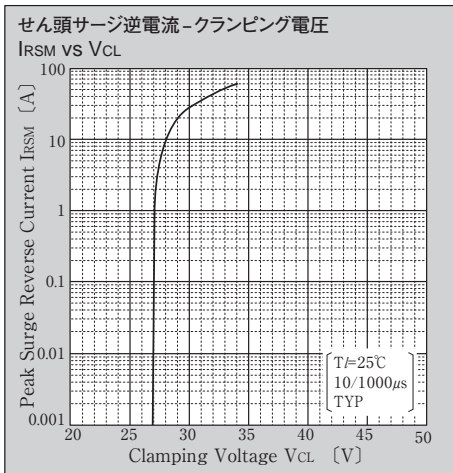

* Sine wave は 50Hz で測定しています。
* 50Hz sine wave is used for measurements.