

MTD2006F

■ 特長 / Features

- 定電流制御機能（周波数固定、他励式）
- 2相入力（1-2相励磁はENAを併用）
- 電流減衰モード切替機能（マイクロステップ駆動対応）
- ノイズキャンセル機能
- 貫通電流防止機能
- 過熱アラーム機能
- 逆起電力吸収ダイオード内蔵
- Constant Current Control Function (Fixed Frequency PWM Control)
- 2-Phase Input (Half Step Drive Uses ENA Together)
- Current Decay Mode (Fast Decay or Slow Decay)
- Noise Cancellation Function
- Cross Conduction Protection
- Overheating Alarm Function
- Built-in Flywheel and Flyback Diodes

■ 絶対最大定格 / Absolute Maximum Ratings

特に指定なき場合はTa=25°C / Ta=25°C unless otherwise specified

項目	Parameter	記号	Symbol	定格値	Rating	単位	Unit
ロジック電源電圧 Logic Supply Voltage			V _{CC}	0 ~ 6		V	
ロジック入力電圧 Logic Input Voltage			V _{LOGIC}	0 ~ V _{CC}		V	
モータ電源電圧 Load Supply Voltage			V _{MM}	35		V	
出力電流 Output Current			I _C	1.3		A	
フライホイールダイオード電流 Flywheel Diode Current			I _F	1.3		A	
許容損失 Power Dissipation			P _D	3		W	
保存温度 Storage Temperature			T _{STG}	-40 ~ 150		°C	
接合部温度 Junction Temperature			T _J	150		°C	

■ 電気的特性 / Electrical Characteristics

特に指定なき場合はTa=25°C, V_{CC}=5V / Ta=25°C, V_{CC}=5V unless otherwise specified

項目	Parameter	記号	Symbol	測定条件	Condition	min.	typ.	max.	単位	Unit
Output stage										
V _{mm} 消費電流 (2 回路 OFF 時) Load Supply Current (2 Circuit OFF)		I _{mm} (OFF)		V _{mm} =35V, V _{ENA} =5V		-	-	8	mA	
上側出力飽和電圧 Output Saturation Voltage (Upper side)		V _{CE(SAT)H}		I _C =0.8A		-	1.0	1.4	V	
下側出力飽和電圧 Output Saturation Voltage (Lower side)		V _{CE(SAT)L}		I _C =0.8A		-	1.0	1.4	V	
上側出力リーク電流 Output Leakage Current (Upper side)		I _{rH}		V _{mm} =35V, V _{OUT} =0V		-	-	10	μA	
下側出力リーク電流 Output Leakage Current (Lower side)		I _{rL}		V _{OUT} =35V, V _{RS} =0V		-	-	10	μA	
上側ダイオード順電圧 Diode Forward Drop (Upper side)		V _{FH}		I _F =0.8A		-	1.3	1.6	V	
下側ダイオード順電圧 Diode Forward Drop (Lower side)		V _{FL}		I _F =0.8A		-	1.3	1.5	V	
Logic stage										
V _{CC} 消費電流 (2 回路 ON 時) Logic Supply Current (2 Circuit ON)		I _{CC} (ON)		V _{ENA} =0A		-	25	33	mA	
V _{CC} 消費電流 (2 回路 OFF 時) Logic Supply Current (2 Circuit OFF)		I _{CC} (OFF)		V _{ENA} =5V		-	19	26	mA	
Phase/Enable/Decay “H” 入力電圧 Phase/Enable/Decay “H” Input Voltage		V _{PHA/ENA/DEC} H				2.3	-	V _{CC}	V	
Phase/Enable/Decay “L” 入力電圧 Phase/Enable/Decay “L” Input Voltage		V _{PHA/ENA/DEC} L				GND	-	0.8	V	
Phase/Enable/Decay “H” 入力電流 Phase/Enable/Decay “H” Input Current		I _{PHA/ENA/DEC} H		V _{PHA/ENA/DEC} =5V		-	-	10	μA	
Phase/Enable “L” 入力電流 Phase/Enable “L” Input Current		I _{PHA/ENA} L		V _{PHA/ENA} =0V		-	-100	-150	μA	
Decay “L” 入力電流 Decay “L” Input Current		I _{DEC} L		V _{DEC} =0V		-	-200	-300	μA	
V _{ref} 入力電流 V _{ref} Input Current		I _{ref}		V _{ref} =0V		-	-1	-10	μA	
V _s 入力電流 V _s Input Current		I _s		V _s =0V		-	-1	-10	μA	
Comp スレッシュホールド Comparator Threshold		V _s		V _{ref} =0.5V		0.475	0.5	0.525	V	
チョッピング周波数 Chopping Frequency		f _{chop}		C _t =3300pF, R _t =18kΩ		-	23	-	kHz	
ブランキングタイム Blanking Time		t _b		C _t =3300pF		-	1.55	-	μs	
V _s 最大電圧 V _s Maximum Voltage		V _s (max)				-	-	1.0	V	
過熱アラーム端子漏れ電流 Thermal Alarm Leakage Current		I _r (alm)		V _{alm} =5V		-	-	10	μA	
過熱アラーム動作端子電流 Thermal Alarm Output Current		I _{alm}		V _{alm} =0.5V		-	-	2	mA	
過熱アラーム動作温度 Thermal Alarm Operating Temperature		T _{alm}				-	140	-	°C	

MTD2006F

■ 基本応用回路 / Typical Application

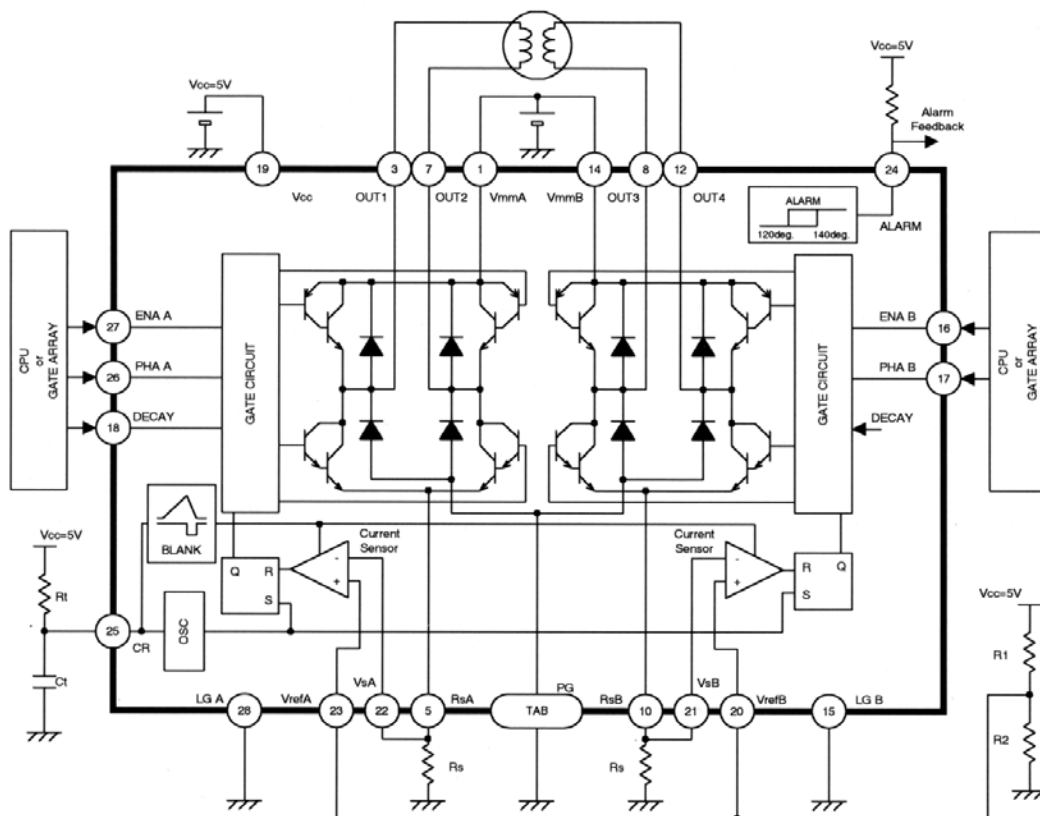

■ 推奨回路定数 / Recommended External Components Value

記号	Symbol	推奨値	Recommendation	単位	Unit
	Rs	0.68		Ω	
	Rt	18		kΩ	
	Ct	3300		pF	
	R1+R2	≤ 10		kΩ	

■ 推奨動作条件 / Recommended Operating Conditions

特に指定なき場合は Ta=25°C / Ta=25°C unless otherwise specified

項目	Parameter	記号	Symbol	推奨値	Recommendation	単位	Unit
接合部温度	Junction Temperature	Tj		-25 ~ 120		°C	
ロジック電源電圧	Logic Supply Voltage	Vcc		4.75 ~ 5.25		V	
モータ電源電圧	Load Supply Voltage	Vmm		5 ~ 31		V	

■ 出力電流, チョッピング周波数の設定 / Setting of Output Current and Chopping Frequency

- 出力電流設定式 / Output Current Setting

$$I_{chop} = \frac{V_{ref}}{R_s} \text{ [A]}$$

- チョッピング周波数設定式 / Chopping Frequency Setting

$$f_{chop} = \frac{1}{0.75 \times C_t \times R_t} \text{ [Hz]}$$

Constant current waveform (Motor current)

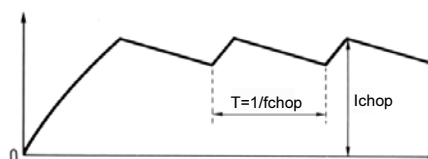

■ ピン配置図／Pin Assignment

Top View MTD2006F

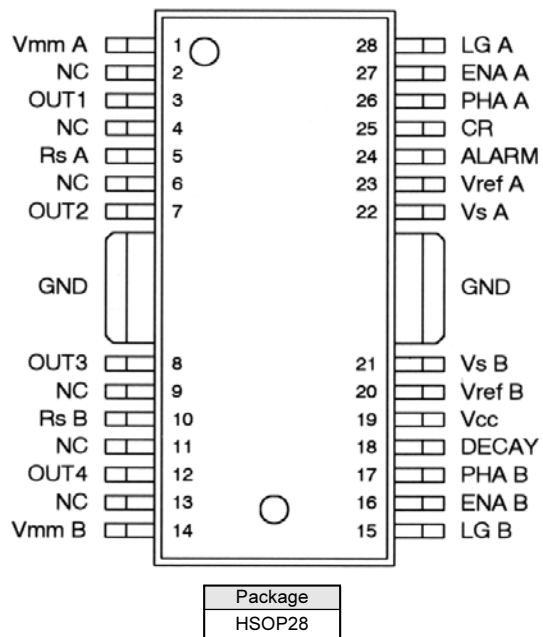

■ 真理値表／Truth Table

ENA A or B	PHA A or B	OUT 1 or 4	OUT 2 or 3
L	L	L	H
L	H	H	L
H	x	OFF	OFF

x : don't care

DECAY	Decay Mode	Switching Transistor
L	Fast	Both source and sink transistor
H	Slow	Only source transistor