

FEATURES

- +3.3 Volt power supply
- I/O Voltage range supports wide +1.65 to +3.6 Volt interfaces
- Fast 45 ns read/write cycle
- SRAM compatible timing
- Unlimited read & write endurance
- Data always non-volatile for >20-years at temperature
- RoHS-compliant small footprint BGA package

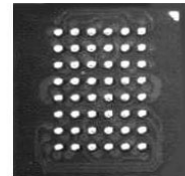
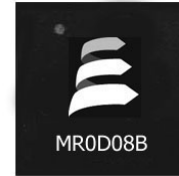

BENEFITS

- One memory replaces FLASH, SRAM, EEPROM and BBSRAM in systems for simpler, more efficient designs
- Improves reliability by replacing battery-backed SRAM



INTRODUCTION

The **MR0D08B** is a dual power supply 1,048,576-bit magnetoresistive random access memory (MRAM) device organized as 131,072 words of 8 bits. It supports I/O voltages from +1.65 to +3.6 volts. The MR0D08B offers SRAM compatible 45ns read/write timing with unlimited endurance. Data is always non-volatile for greater than 20-years. Data is automatically protected on power loss by low-voltage inhibit circuitry to prevent writes with voltage out of specification. The MR0D08B is the ideal memory solution for applications that must permanently store and retrieve critical data and programs quickly.

The **MR0D08B** is available in small footprint 8 mm x 8 mm, 48-pin ball grid array (BGA) package with 0.75 mm ball centers.

The **MR0D08B** provides highly reliable data storage over a wide range of temperatures. The product is offered with commercial temperature (0 to +70 °C).

CONTENTS

1. DEVICE PIN ASSIGNMENT.....	2
2. ELECTRICAL SPECIFICATIONS.....	4
3. TIMING SPECIFICATIONS.....	8
4. ORDERING INFORMATION.....	13
5. MECHANICAL DRAWING.....	14
6. REVISION HISTORY.....	15
How to Reach Us.....	15

1. DEVICE PIN ASSIGNMENT

Figure 1.1 Block Diagram

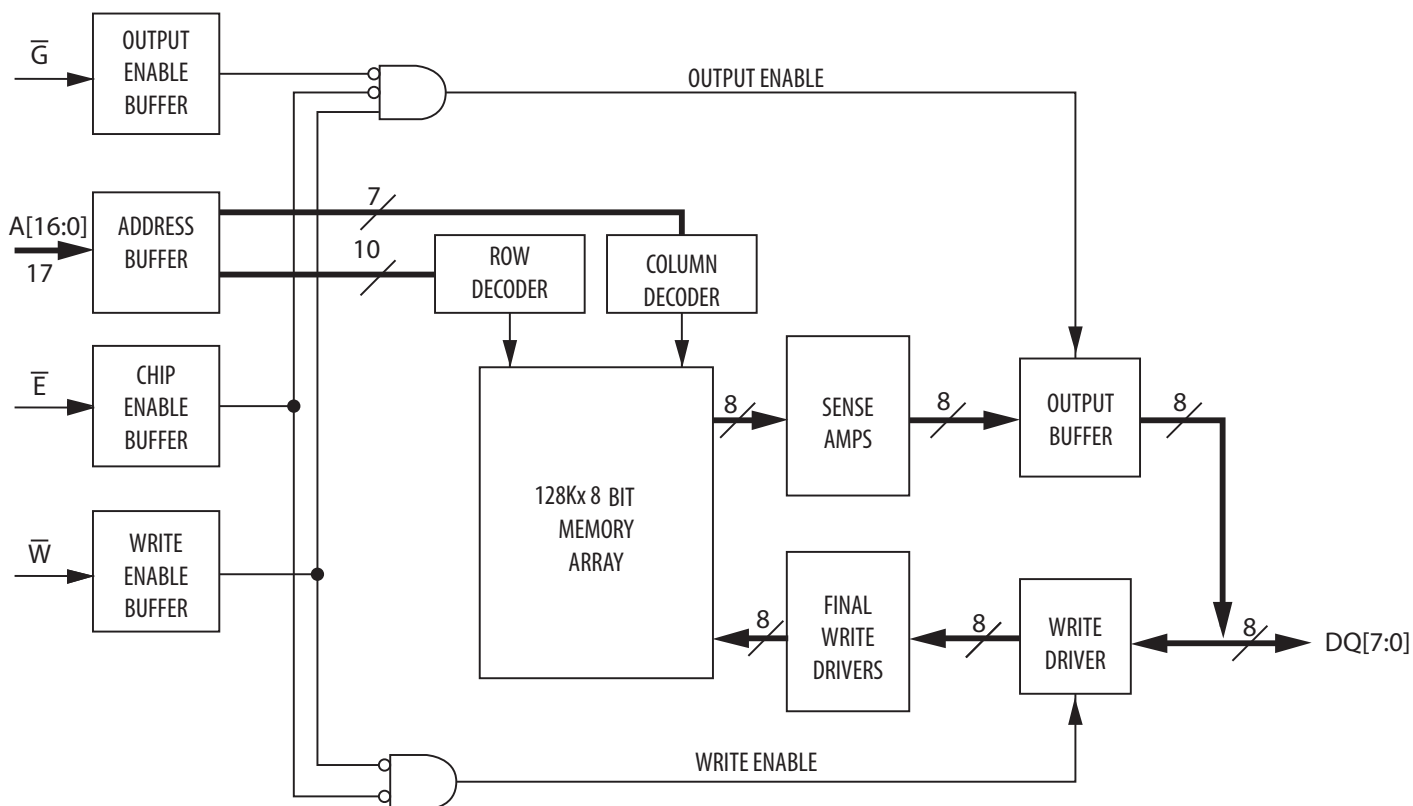
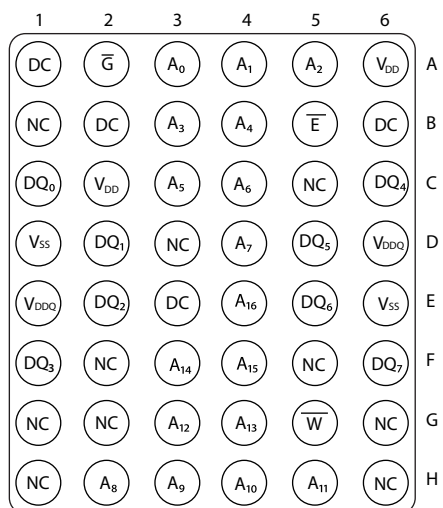

Table 1.1 Pin Functions

Signal Name	Function
A	Address Input
\bar{E}	Chip Enable
\bar{W}	Write Enable
\bar{G}	Output Enable
DQ	Data I/O
V_{DD}	Power Supply
V_{DDQ}	I/O Power Supply
V_{SS}	Ground
DC	Do Not Connect
NC	No Connection, Ball D3, H1, H6, G2 Reserved for Future Expansion

Figure 1.2 Pin Diagrams for Available Packages (Top View)



48 Pin FBGA

Table 1.2 Operating Modes

\overline{E}^1	\overline{G}^1	\overline{W}^1	Mode	V _{DD} Current	DQ[7:0] ²
H	X	X	Not selected	I _{SB1} , I _{SB2}	Hi-Z
L	H	H	Output disabled	I _{DDR}	Hi-Z
L	L	H	Byte Read	I _{DDR}	D _{Out}
L	X	L	Byte Write	I _{DDW}	D _{in}

¹ H = high, L = low, X = don't care

² Hi-Z = high impedance

2. ELECTRICAL SPECIFICATIONS

Absolute Maximum Ratings

This device contains circuitry to protect the inputs against damage caused by high static voltages or electric fields; however, it is advised that normal precautions be taken to avoid application of any voltage greater than maximum rated voltages to these high-impedance (Hi-Z) circuits.

The device also contains protection against external magnetic fields. Precautions should be taken to avoid application of any magnetic field more intense than the maximum field intensity specified in the maximum ratings.

Table 2.1 Absolute Maximum Ratings¹

Parameter	Symbol	Value	Unit
Core Supply voltage ²	V_{DD}	-0.5 to 4.0	V
I/O Power Supply voltage ²	V_{DDQ}	-0.5 to 4.0	V
Voltage on any pin ²	V_{IN}	-0.5 to +4.0 or $V_{DDQ} + 0.5$ <i>whichever is less</i>	V
Output current per pin	I_{OUT}	± 20	mA
Package power dissipation ³	P_D	0.600	W
Temperature under bias	T_{BIAS}	-10 to 85	°C
Storage Temperature	T_{stg}	-55 to 150	°C
Lead temperature during solder (3 minute max)	T_{Lead}	260	°C
Maximum magnetic field during write	H_{max_write}	2000	A/m
Maximum magnetic field during read or standby	H_{max_read}	8000	A/m

¹ Permanent device damage may occur if absolute maximum ratings are exceeded. Functional operation should be restricted to recommended operating conditions. Exposure to excessive voltages or magnetic fields could affect device reliability.

² All voltages are referenced to V_{SS} .

³ Power dissipation capability depends on package characteristics and use environment.

Table 2.2 Operating Conditions

Parameter	Symbol	Min	Typical	Max	Unit
Core Power supply voltage	V_{DD}	3.0 ¹	3.3	3.6	V
I/O Power supply voltage	V_{DDQ}	1.65 ¹	-	3.6	V
Write inhibit voltage	V_{WIDD}	2.5	2.7	3.0 ¹	V
Write inhibit voltage	V_{WIDDQ}	1.2	1.4	1.65 ¹	V
Input high voltage ($V_{DDQ}=1.65-2.2V$)	V_{IH}	1.4	-	$V_{DDQ} + 0.2^2$	V
Input high voltage ($V_{DDQ}=2.2-2.7V$)	V_{IH}	1.8	-	$V_{DDQ} + 0.2^2$	V
Input high voltage ($V_{DDQ}=2.7-3.6V$)	V_{IH}	2.2	-	$V_{DDQ} + 0.2^2$	V
Input low voltage ($V_{DDQ}=1.65-2.2V$)	V_{IL}	-0.2 ³	-	0.4	V
Input low voltage ($V_{DDQ}=2.2-2.7V$)	V_{IL}	-0.2 ³	-	0.6	V
Input low voltage ($V_{DDQ}=2.7-3.6V$)	V_{IL}	-0.2 ³	-	0.8	V
Temperature under bias	T_A	0		70	°C

¹ $V_{DDQ} \leq V_{DD}$. Write inhibit occurs when either V_{DD} or V_{DDQ} drops below its write inhibit voltage. There is a 2 ms startup time once V_{DD} exceeds $V_{DD}(\min)$. See **Power Up and Power Down Sequencing**.

² $V_{IH}(\max) = V_{DDQ} + 0.2$ V DC ; $V_{IH}(\max) = V_{DDQ} + 0.5$ V AC (pulse width ≤ 20 ns) for $I \leq 20.0$ mA.

³ $V_{IL}(\min) = -0.2$ V DC ; $V_{IL}(\min) = -2.0$ V AC (pulse width ≤ 20 ns) for $I \leq 20.0$ mA.

Power Up and Power Down Sequencing

The MRAM is protected from write operations whenever V_{DD} is less than V_{WIDD} or V_{DDQ} is less than V_{WIDDQ} . As soon as V_{DD} exceeds $V_{DD}(\text{min})$ and V_{DDQ} exceeds $V_{DDQ}(\text{min})$, there is a startup time of 2 ms before read or write operations can start. This time allows memory power supplies to stabilize.

The \bar{E} and \bar{W} control signals should track V_{DD} on power up to $V_{DD} - 0.2\text{ V}$ or V_{IH} (whichever is lower) and remain high for the startup time. In most systems, this means that these signals should be pulled up with a resistor so that signal remains high if the driving signal is Hi-Z during power up. Any logic that drives \bar{E} and \bar{W} should hold the signals high with a power-on reset signal for longer than the startup time.

During power loss or brownout where either V_{DD} goes below V_{WIDD} or V_{DDQ} goes below V_{WIDDQ} , writes are protected and a startup time must be observed when power returns above $V_{DD}(\text{min})$ and / or V_{DDQ} .

Figure 2.1 Power Up and Power Down Diagram

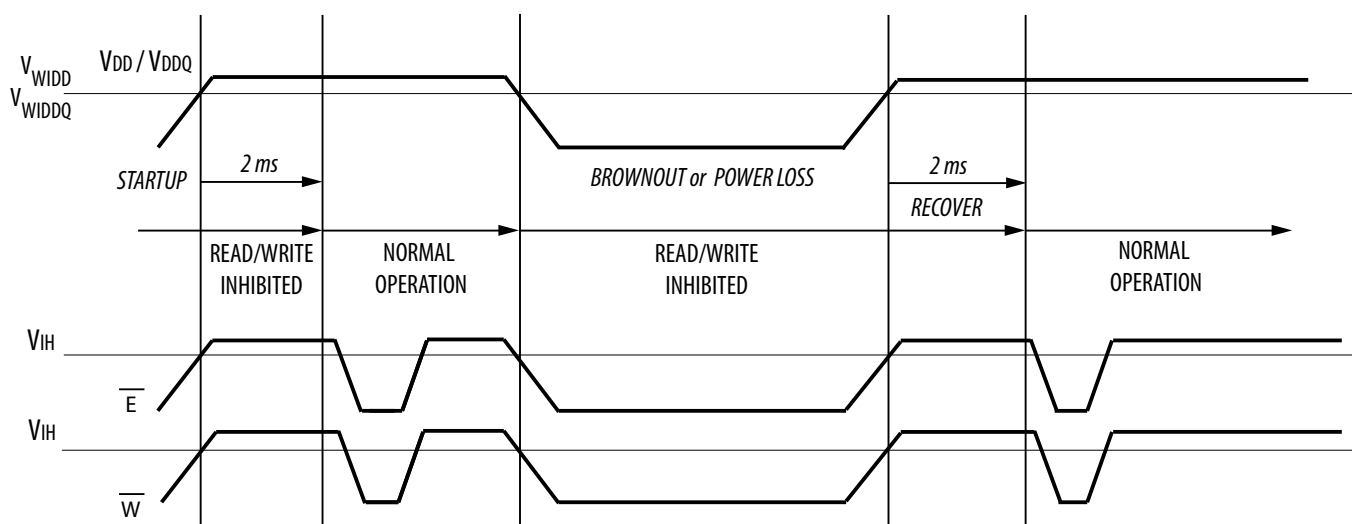

Table 2.3 DC Characteristics

Parameter	Symbol	Min	Typical	Max	Unit
Input leakage current	$I_{lkg(I)}$	-	-	± 1	μA
Output leakage current	$I_{lkg(O)}$	-	-	± 1	μA
Output low voltage ($V_{DDQ}=1.65-2.2V@ 0.1mA$)	V_{OL}	-	-	0.2	V
Output low voltage ($V_{DDQ}=2.2-2.7V@ 0.1mA$)	V_{OL}	-	-	0.4	V
Output low voltage ($V_{DDQ}=2.7-3.6V@ 2.1 mA$)	V_{OL}	-	-	0.4	V
Output high voltage ($V_{DDQ}=1.65-2.2V@ -0.1 mA$)	V_{OH}	1.4	-	-	V
Output high voltage ($V_{DDQ}=2.2-2.7V@ -0.1 mA$)	V_{OH}	2	-	-	V
Output high voltage ($V_{DDQ}=2.7-3.6V@ -1.0 mA$)	V_{OH}	2.4	-	-	V

Table 2.4 Power Supply Characteristics

Parameter	Symbol	Typical	Max	Unit
AC active supply current - read modes ¹ ($I_{OUT} = 0 mA, V_{DD} = max$)	I_{DDR}	25	30	mA
AC active supply current - write modes ¹ ($V_{DD} = max$)	I_{DDW}	55	65	mA
AC active operating current ($V_{DDQ} = V_{IH} = 3.6V, V_{IL} = 0V$) <i>input transitions < 2ns, no output load</i>	I_{DDQ}	0.50	2	mA
AC standby current ($V_{DD} = max, \bar{E} = V_{IH}$) <i>no other restrictions on other inputs</i>	I_{SB1}	6	8	mA
CMOS standby current ($\bar{E} \geq V_{DD} - 0.2V$ and $V_{In} \leq V_{SS} + 0.2V$ or $\geq V_{DDQ} - 0.2V$) ($V_{DD} = max, f = 0 MHz$)	I_{SB2}	5	7	mA

¹ All active current measurements are measured with one address transition per cycle and at minimum cycle time.

3. TIMING SPECIFICATIONS

Table 3.1 Capacitance¹

Parameter	Symbol	Typical	Max	Unit
Address input capacitance	C_{In}	-	6	pF
Control input capacitance	C_{In}	-	6	pF
Input/Output capacitance	$C_{I/O}$	-	8	pF

¹ $f = 1.0 \text{ MHz}$, $V_{DDQ} = V_{DDQ}(typ)$, $T_A = 25 \text{ }^\circ\text{C}$, periodically sampled rather than 100% tested.

Table 3.2 AC Measurement Conditions

Parameter	$V_{DDQ}=1.8$	$V_{DDQ}=2.5$	$V_{DDQ}=3.3$	Unit
Logic input timing measurement reference level	0.8	0.8	0.8	V
Logic output timing measurement reference level	0.8	0.8	0.8	V
Logic input pulse levels	0 or 1.8	0 or 2.5	0 or 3.3	V
Output load voltage (V_L) for low & high impedance parameters (Figure 3.1)	0.8	1.2	1.75	V
Output load resistor (R1) for all other timing	13,500	16,600	1,103	Ω
Output load resistor (R2) for all other timing	10,800	15,400	1,554	Ω

Figure 3.1 Output Load Test Low and High

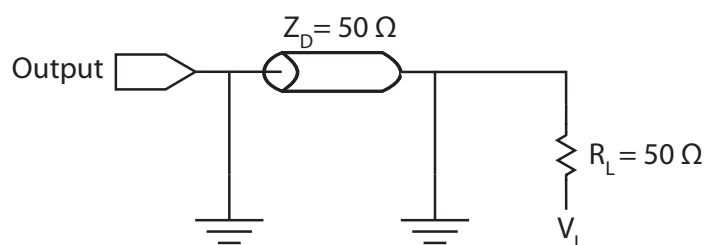

Figure 3.2 Output Load Test All Others

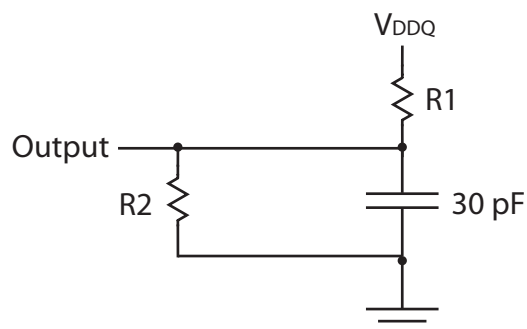

Table 3.4 Write Cycle Timing 1 (\overline{W} Controlled)¹

Parameter	Symbol	Min	Max	Unit
Write cycle time ²	t_{AVAV}	45	-	ns
Address set-up time	t_{AVWL}	0	-	ns
Address valid to end of write (\overline{G} high)	t_{AVWH}	25	-	ns
Address valid to end of write (\overline{G} low)	t_{AVWH}	25	-	ns
Write pulse width (\overline{G} high)	t_{WLWH} t_{WLEH}	20	-	ns
Write pulse width (\overline{G} low)	t_{WLWH} t_{WLEH}	20	-	ns
Data valid to end of write	t_{DVWH}	15	-	ns
Data hold time	t_{WHDX}	0	-	ns
Write low to data Hi-Z ³	t_{WLQZ}	0	15	ns
Write high to output active ³	t_{WHQX}	3	-	ns
Write recovery time	t_{WHAX}	12	-	ns

- ¹ All writes occur during the overlap of \overline{E} low and \overline{W} low. Power supplies must be properly grounded and decoupled and bus contention conditions must be minimized or eliminated during read and write cycles. If \overline{G} goes low at the same time or after \overline{W} goes low, the output will remain in a high impedance state. After \overline{W} or \overline{E} has been brought high, the signal must remain in steady-state high for a minimum of 2 ns. The minimum time between \overline{E} being asserted low in one cycle to \overline{E} being asserted low in a subsequent cycle is the same as the minimum cycle time allowed for the device.
- ² All write cycle timings are referenced from the last valid address to the first transition address.
- ³ This parameter is sampled and not 100% tested. Transition is measured ± 200 mV from the steady-state voltage. At any given voltage or temperature, $t_{WLQZ}(\text{max}) < t_{WHQX}(\text{min})$

Figure 3.4 Write Cycle Timing 1 (\overline{W} Controlled)

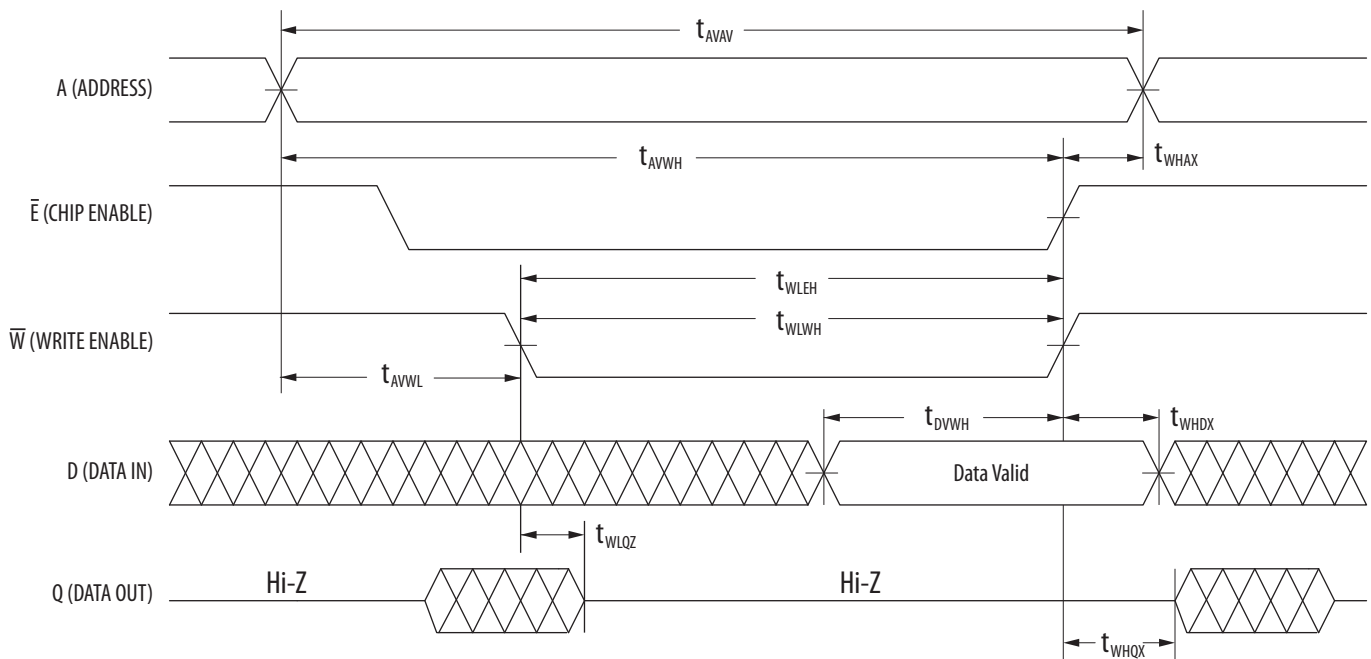

Table 3.5 Write Cycle Timing 2 (\bar{E} Controlled)¹

Parameter	Symbol	Min	Max	Unit
Write cycle time ²	t_{AVAV}	45	-	ns
Address set-up time	t_{AVEL}	0	-	ns
Address valid to end of write (\bar{G} high)	t_{AVEH}	25	-	ns
Address valid to end of write (\bar{G} low)	t_{AVEH}	25	-	ns
Enable to end of write (\bar{G} high)	t_{ELEH} t_{ELWH}	20	-	ns
Enable to end of write (\bar{G} low) ³	t_{ELEH} t_{ELWH}	20	-	ns
Data valid to end of write	t_{DVEH}	15	-	ns
Data hold time	t_{EHDX}	0	-	ns
Write recovery time	t_{EHAX}	12	-	ns

¹ All writes occur during the overlap of \bar{E} low and \bar{W} low. Power supplies must be properly grounded and decoupled and bus contention conditions must be minimized or eliminated during read and write cycles. If \bar{G} goes low at the same time or after \bar{W} goes low, the output will remain in a high impedance state. After \bar{W} or \bar{E} has been brought high, the signal must remain in steady-state high for a minimum of 2 ns. The minimum time between \bar{E} being asserted low in one cycle to \bar{E} being asserted low in a subsequent cycle is the same as the minimum cycle time allowed for the device.

² All write cycle timings are referenced from the last valid address to the first transition address.

³ If \bar{E} goes low at the same time or after \bar{W} goes low, the output will remain in a high-impedance state. If \bar{E} goes high at the same time or before \bar{W} goes high, the output will remain in a high-impedance state.

Figure 3.5 Write Cycle Timing 2 (\bar{E} Controlled)

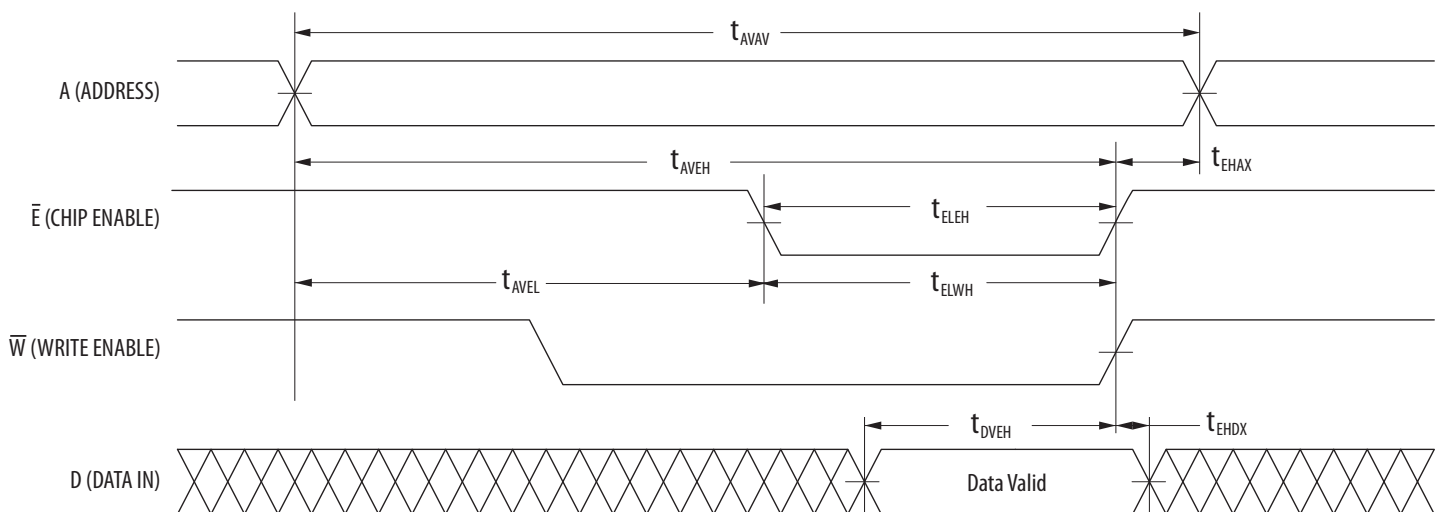

Table 3.6 Write Cycle Timing 3 (Shortened t_{WHAX} , \bar{W} and \bar{E} Controlled)¹

Parameter	Symbol	Min	Max	Unit
Write cycle time ²	t_{AVAV}	45	-	ns
Address set-up time —	t_{AVWL}	0	-	ns
Address valid to end of write (\bar{G} high)	t_{AVWH}	25	-	ns
Address valid to end of write (G low)	t_{AVWH}	25	-	ns
Write pulse width	t_{WLWH} t_{WLEH}	20	-	ns
Data valid to end of write	t_{DVWH}	15	-	ns
Data hold time	t_{WHDX}	0	-	ns
Enable recovery time	t_{EHAX}	-2	-	ns
Write recovery time ³	t_{WHAX}	6	-	ns
Write to enable recovery time ³	t_{WHEL}	12	-	ns

¹ All writes occur during the overlap of \bar{E} low and \bar{W} low. Power supplies must be properly grounded and decoupled and bus contention conditions must be minimized or eliminated during read and write cycles. If \bar{G} goes low at the same time or after \bar{W} goes low, the output will remain in a high impedance state. After \bar{W} or \bar{E} has been brought high, the signal must remain in steady-state high for a minimum of 2 ns. The minimum time between \bar{E} being asserted low in one cycle to \bar{E} being asserted low in a subsequent cycle is the same as the minimum cycle time allowed for the device.

² All write cycle timings are referenced from the last valid address to the first transition address.

³ If \bar{E} goes low at the same time or after \bar{W} goes low, the output will remain in a high-impedance state. If \bar{E} goes high at the same time or before \bar{W} goes high, the output will remain in a high-impedance state.

Table 3.6 Write Cycle Timing 3 (Shortened t_{WHAX} , \bar{W} and \bar{E} Controlled)

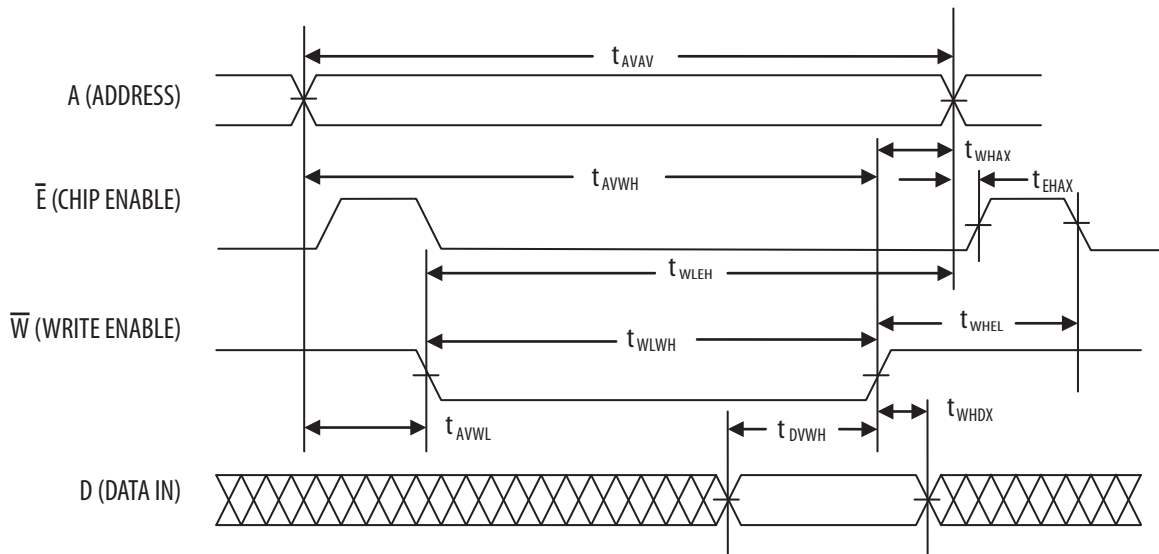

4. ORDERING INFORMATION

Figure 4.1 Part Numbering System

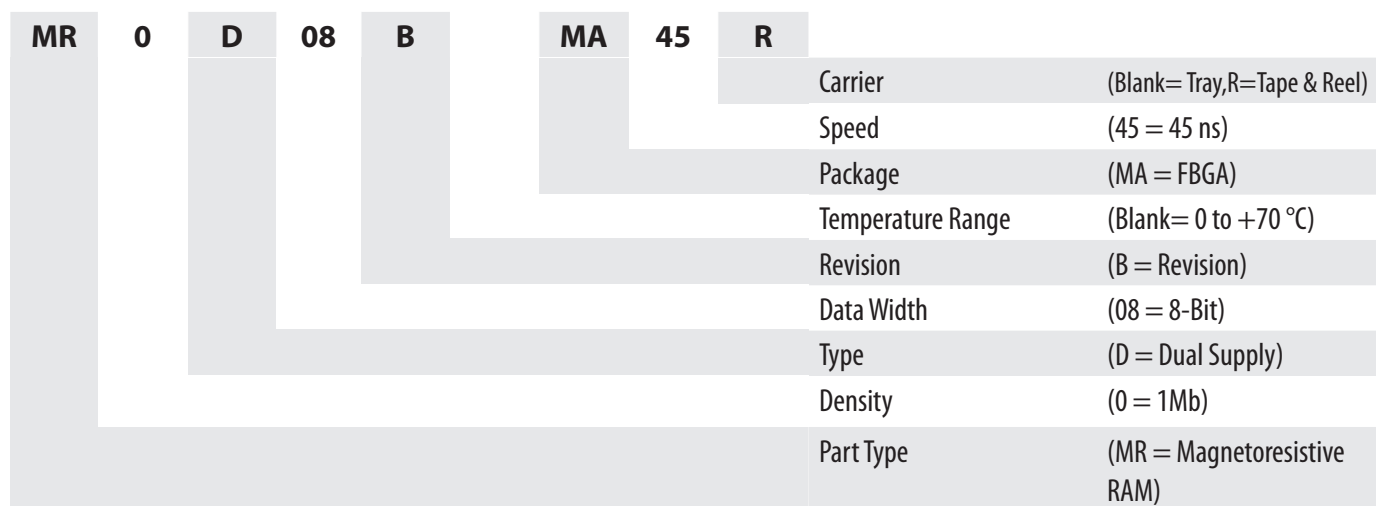
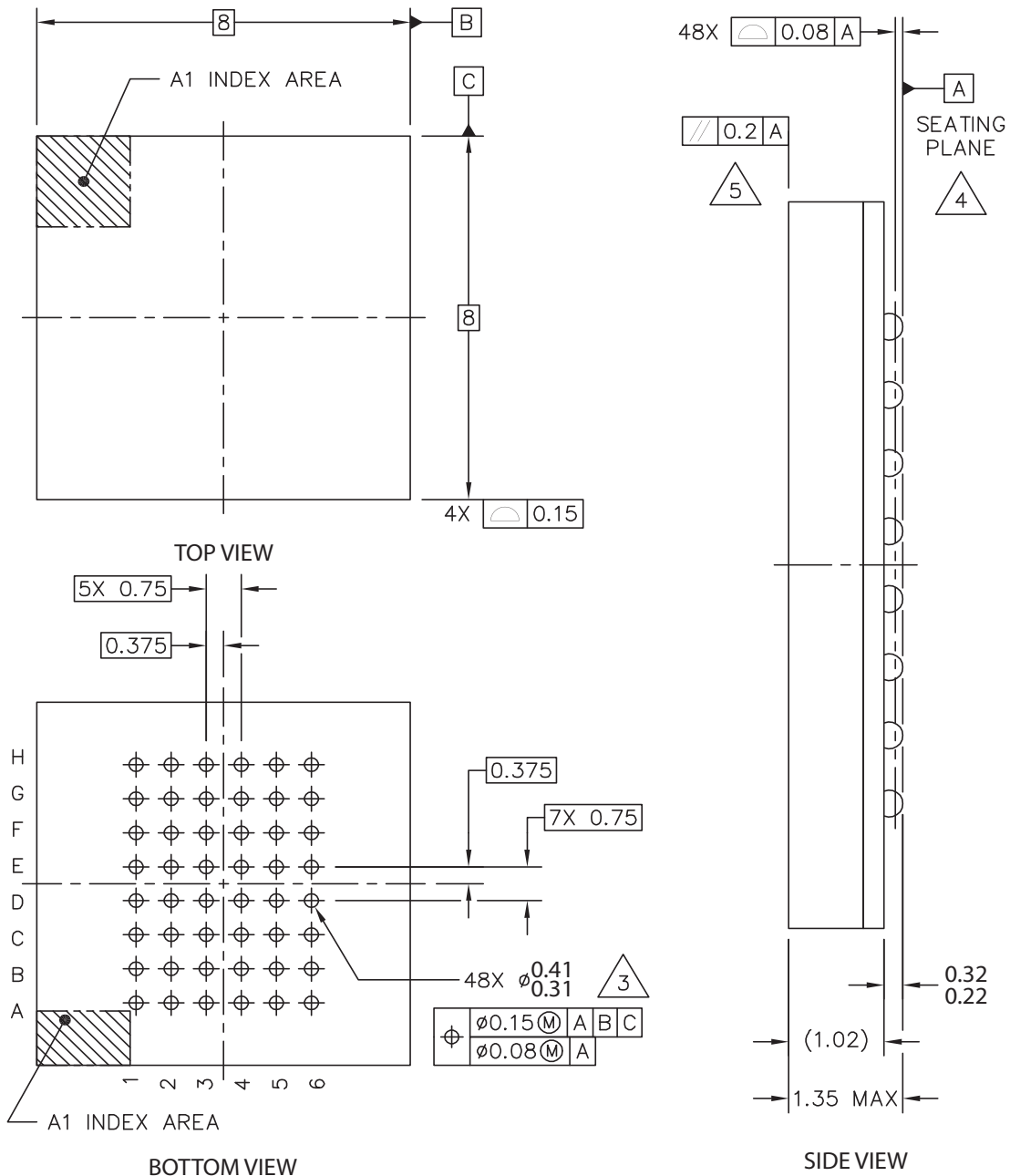

Table 4.1 Available Parts

Part Number	Description	Temperature
MR0D08BMA45	Dual Supply 128x8 MRAM 48-BGA	Commercial
MR0D08BMA45R	Dual Supply 128x8 MRAM 48-BGA Tape & Reel	Commercial

Figure 5.1 FBGA



Print Version Not To Scale

- 1. Dimensions in Millimeters.
- 2. Dimensions and tolerances per ASME Y14.5M - 1994.
- 3. Maximum solder ball diameter measured parallel to DATUM A
- 4. DATUM A, the seating plane is determined by the spherical crowns of the solder balls.
- 5. Parallelism measurement shall exclude any effect of mark on top surface of package.

6. REVISION HISTORY

Revision	Date	Description of Change
0	Aug 24, 2009	Initial Product Concept
1	Oct 22, 2009	Added Write Cycle Timing 3. In table 2.4, I_{SB1} max changes from 7 to 8 mA and I_{SB2} from 6 to 7 mA. Added Tape & Reel Option in table 4.1. Changed to Production Level
2	Apr 7, 2010	Added I_{DDQ} specification in table 2.4.
3	Dec 9, 2011	Corrected Figure 5.1 FBGA drawing ball dimensions.

Contact Information:

How to Reach Us:

Home Page:
www.everspin.com

E-Mail:

support@everspin.com
orders@everspin.com
sales@everspin.com

USA/Canada/South and Central America

Everspin Technologies
1347 N. Alma School Road, Suite 220
Chandler, Arizona 85224
+1-877-347-MRAM (6726)
+1-480-347-1111

Europe, Middle East and Africa

support.europe@everspin.com

Japan

support.japan@everspin.com

Asia Pacific

support.asia@everspin.com

File Name:

MR0D08B_Datasheet_EST370_Rev3.pdf

Information in this document is provided solely to enable system and software implementers to use Everspin Technologies products. There are no express or implied licenses granted hereunder to design or fabricate any integrated circuit or circuits based on the information in this document. Everspin Technologies reserves the right to make changes without further notice to any products herein. Everspin makes no warranty, representation or guarantee regarding the suitability of its products for any particular purpose, nor does Everspin Technologies assume any liability arising out of the application or use of any product or circuit, and specifically disclaims any and all liability, including without limitation consequential or incidental damages. "Typical" parameters, which may be provided in Everspin Technologies data sheets and/or specifications can and do vary in different applications and actual performance may vary over time. All operating parameters including "Typicals" must be validated for each customer application by customer's technical experts. Everspin Technologies does not convey any license under its patent rights nor the rights of others. Everspin Technologies products are not designed, intended, or authorized for use as components in systems intended for surgical implant into the body, or other applications intended to support or sustain life, or for any other application in which the failure of the Everspin Technologies product could create a situation where personal injury or death may occur. Should Buyer purchase or use Everspin Technologies products for any such unintended or unauthorized application, Buyer shall indemnify and hold Everspin Technologies and its officers, employees, subsidiaries, affiliates, and distributors harmless against all claims, costs, damages, and expenses, and reasonable attorney fees arising out of, directly or indirectly, any claim of personal injury or death associated with such unintended or unauthorized use, even if such claim alleges that Everspin Technologies was negligent regarding the design or manufacture of the part. Everspin™ and the Everspin logo are trademarks of Everspin Technologies, Inc. All other product or service names are the property of their respective owners.

©Everspin Technologies, Inc. 2011

