

**Magnetically actuated
Linear position sensor
WIM200-Q25L-LIU5X2-H1141**

- Cuboid-shaped, aluminium / plastic
- Versatile mounting possibilities
- Measuring range indication via LED
- Immune to external magnetic fields
- Extremely short blind zones
- 4-wire, 15...30 VDC
- Analog output
- 0...10 V and 4...20 mA
- Male connector, M12 x 1

Wiring diagram

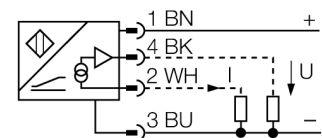

Functional principle

Linear position sensors operate on the Hall principle and accomplish simple control tasks. They provide an output signal proportional to the actuating magnet. The polarity of the magnet has no effect on the output signal. The outstanding features of these robust sensors are excellent repeatability, resolution and linearity, excellent electromagnetic capability and a broad temperature range.

Characteristic

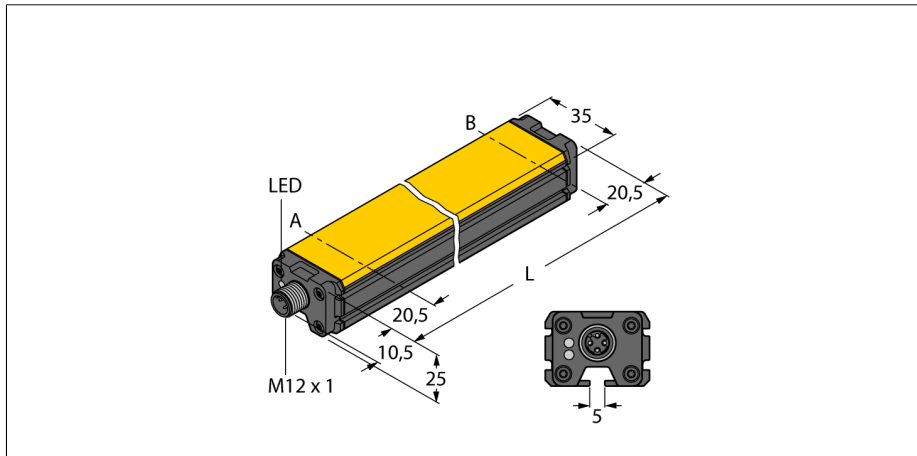
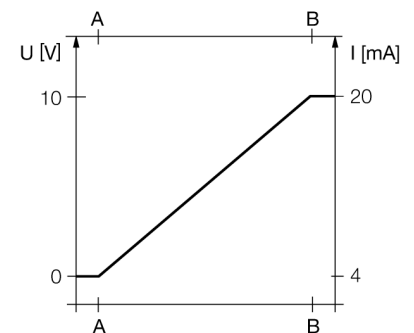

Type code	WIM200-Q25L-LIU5X2-H1141
Ident no.	1536633
Measuring range [A...B]	200mm
Resolution	0,2 mm/10 bit
Repeatability	≤ 0.1% of measuring range IA - BI ≤ depending on positioning element
Linearity deviation	≤ 1 % of full scale
Temperature drift	≤ ± 0.006 % / K
Ambient temperature	-25...+70 °C
Operating voltage	15...30VDC
Residual ripple	≤ 10 % U _{in}
No-load current I ₀	≤ 15 mA
Rated insulation voltage	≤ 0.5 kV
Short-circuit protection	yes
Wire breakage / Reverse polarity protection	yes/ complete
Output function	4-wire, Analog output
Voltage output	0...10V
Current output	4...20mA
Load resistance voltage output	≥ 4.7 kΩ
Load resistance current output	≤ 0.4 kΩ
Sample rate	200 Hz
Design	rectangular, Q25L
Dimensions	241x 35x 25 mm
Housing material	Aluminium
Connection	male, M12 x 1
Vibration resistance	55 Hz (1 mm)
Shock resistance	30 g (11 ms)
Protection class	IP67
Operating voltage	LED green
Measuring range display	LED, yellow, positioning element in measuring range

**Magnetically actuated
Linear position sensor
WIM200-Q25L-LIU5X2-H1141**

TURCK

Industrial
Automation

Mounting instructions / Description

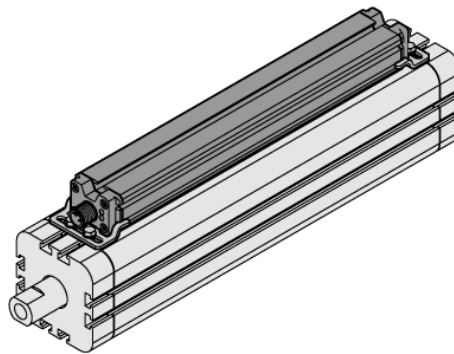
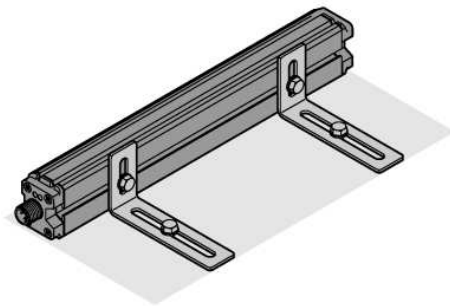
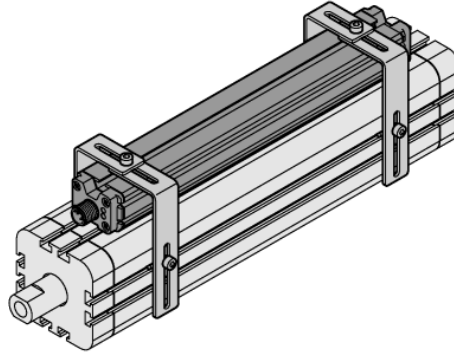
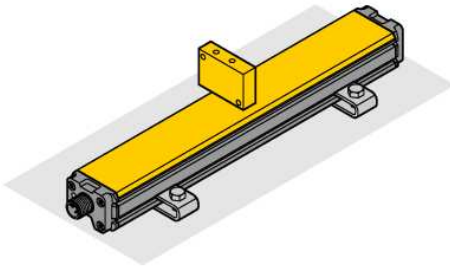

Numerous accessories allow the sensor to be mounted in various positions. Opposite to the active face the sensor housing features a mounting groove for which sliding blocks are available. The lateral slot profiles can be used for mounting, too.

When used with an external positioning element, the sensor can either be mounted with the active face opposite or laterally to the mounting surface. Drilling slots guarantee highest flexibility for fine adjustment.

The mounting accessories for linear position sensors can be adjusted to the corresponding cylinder sizes. The stainless steel accessories guarantee safe and robust mounting as well as highest flexibility. .

**Magnetically actuated
Linear position sensor
WIM200-Q25L-LIU5X2-H1141**

Accessories

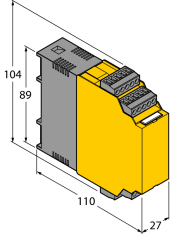
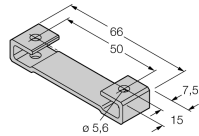
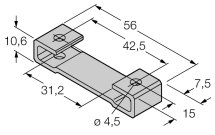
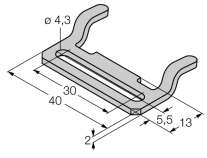
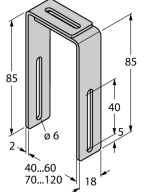
Type code	Ident no.	Description	Dimension drawing
IM43-13-SR	7540041	Limit value monitor; 1-channel; input 0/4...20 mA or 0/2...10 V; supply of 2- or 3-wire transmitters/sensors; limit value adjustment via teach button; three relay outputs with one NO contact each; removable terminal blocks; 27 mm wide; universal voltage supply 20...250 VUC; further limit value monitors are described in our "Interface Technology" catalog.	
M1-Q25L	6901045	Mounting foot for linear position sensor Q25L; aluminium; 2 pcs. per bag	
M2-Q25L	6901046	Mounting foot for linear position sensor Q25L; aluminium; 2 pcs. per bag	
MB1-Q25	6901026	Mounting clip for linear position sensor Q25L; material Stainless steel; 2 pcs. per bag	
MB2.1-Q25	6901027	Mounting bracket for linear position sensors Q25L; mounting on pneumatic cylinders (40...60mm); material: Stainless steel; 4 pcs. per bag	

**Magnetically actuated
Linear position sensor
WIM200-Q25L-LIU5X2-H1141**

Accessories

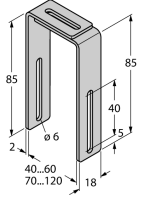
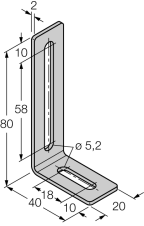
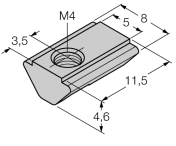
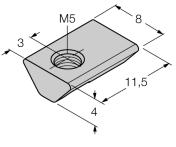
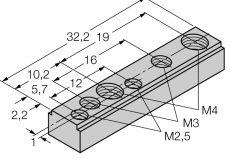
Type code	Ident no.	Description	Dimension drawing
MB2.2-Q25	6901028	Mounting bracket for linear position sensors Q25L; mounting on pneumatic cylinders (70...120mm); material: Stainless steel; 4 pcs. per bag	
M4-Q25L	6901048	Mounting bracket for linear position sensor Q25L; material Stainless steel; 2 pcs. per bag	
MN-M4-Q25	6901025	Sliding block with M4 thread for the backside profile of the Q25L; material Brass; 10 pcs. per bag	
MN-M5-Q25	6901039	Sliding block with M5 thread for the backside profile of the Q25L; material Stainless steel; 10 pcs. per bag	
MN-C	6901024	Sliding block for T-groove cylinder 5-8mm; 1 pcs. per bag	

**Magnetically actuated
Linear position sensor
WIM200-Q25L-LIU5X2-H1141**

Accessories

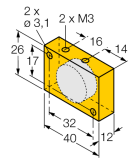
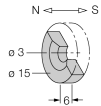
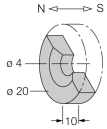
Type code	Ident no.	Description	Dimension drawing
DM-Q12	6900367	Actuation magnet; cuboid-shaped plastic; sensing range 58 mm on BIM-(E)M12 sensors resp. 49 mm on BIM-EG08 sensors; in combination with Q25: Recommended distance between sensor and magnet: 3 ... 5 mm	
DMR15-6-3	6900216	Actuation magnet, Ø 15 mm (Ø 3 mm), h: 6 mm; sensing range 36 mm on BIM-(E)M12 sensors resp. 32 mm on BIM-EG08 sensors; in combination with Q25L: Recommended distance between sensor and magnet: 3 ... 4 mm	
DMR20-10-4	6900214	Actuation magnet; Ø 20 mm (Ø 4 mm), h: 10 mm; sensing range 59 mm on BIM-(E)M12 sensors resp. 50 mm on BIM-EG08 sensors; in combination with Q25L: Recommended distance between sensor and magnet: 3 ... 4 mm	
DMR31-15-5	6900215	Actuation magnet, Ø 31 mm (Ø 5 mm), h: 15 mm; sensing range 90 mm on BIM-(E)M12 sensors resp. 78 mm on BIM-EG08 sensors; in combination with Q25L: Recommended distance between sensor and magnet: 3 ... 5 mm	