

**Inductive sensor  
with extended temperature range  
BI15-CP40-FZ3X2/S100**

- Rectangular, height 40 mm
- Variable orientation of active face in 9 directions
- Plastic, PBT-GF30-V0
- High luminance corner LEDs
- Optimum view on supply voltage and switching state from any position
- For temperatures up to +100 °C
- AC 2-wire, 20...250 VAC
- DC 2-wire, 10...300 VDC
- NO/NC programmable
- Terminal chamber

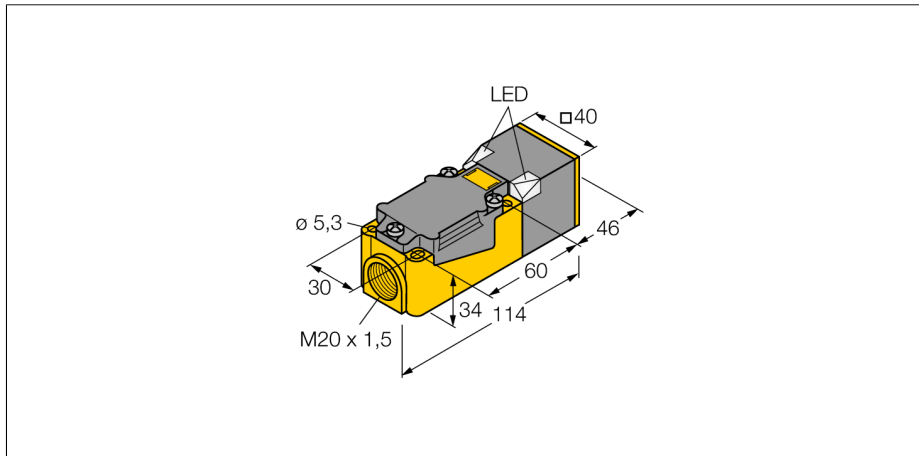

<b>Type code</b>	BI15-CP40-FZ3X2/S100
Ident no.	13440
<b>Rated operating distance Sn</b>	15 mm
Mounting condition	flush
Assured sensing range	≤ (0,81 x Sn) mm
Correction factors	St37 = 1; Al = 0.3; stainless steel = 0.7; Ms = 0.4
Repeatability	≤ 2 % of full scale
Temperaturdrift	10 %
Hysteresis	≤ ± 20 %, ≥ +70 °C
Ambient temperature	3...15 %
	-25...+100 °C
<b>Operating voltage</b>	20...250 VAC
Operating voltage	10...300VDC
AC rated operational current	≤ 400 mA
DC rated operational current	≤ 300 mA
Rated operational current	see derating curve
Frequency	≥ 50...≤ 60 Hz
Residual current	≤ 1.7 mA
Rated insulation voltage	≤ 1.5 kV
Surge current	≤ 8 A (≤ 10 ms max. 5 Hz)
Voltage drop at I <sub>e</sub>	≤ 6 V
Output function	2-wire, connection programmable
Smallest operating current I <sub>o</sub>	≤ 3 mA
Switching frequency	0.02 kHz
<b>Design</b>	rectangular, CP40
Dimensions	114x 40x 40 mm
Housing material	Plastic, PBT, black
Connection	Terminal chamber
Clamping ability	≤ 2.5 mm <sup>2</sup>
Vibration resistance	55 Hz (1 mm)
Shock resistance	30 g (11 ms)
Protection class	IP67
MTTF	2283 years acc. to SN 29500 (Ed. 99) 40 °C
<b>Operating voltage</b>	LED green
Switching state	● red

**Wiring diagram**

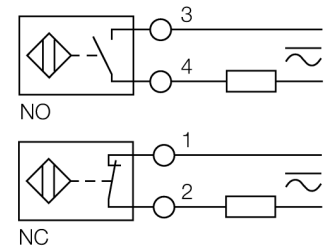

**Functional principle**

Inductive sensors detect metal objects contactless and wear-free. For this purpose they use a high-frequency electromagnetic AC field that interacts with the target. The sensors hosting a ferrite core coil generate the AC field through an LC resonant circuit. Special versions are available for ambient temperatures between -60°C and +250°C.

**derating curve**

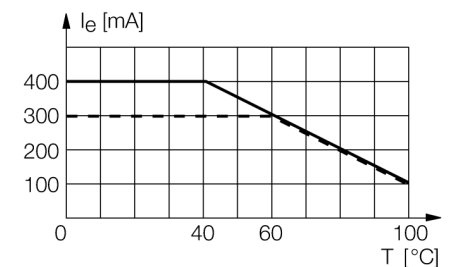

**Inductive sensor  
with extended temperature range  
BI15-CP40-FZ3X2/S100**

Distance D	2 x B
Distance W	3 x Sn
Distance S	1 x B
Distance G	6 x Sn
<hr/>	
Width of the active face B	40 mm

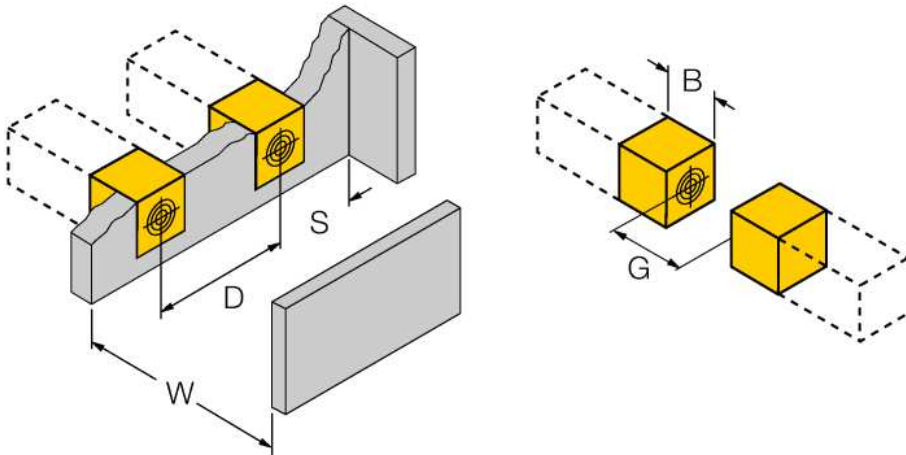

**Inductive sensor  
with extended temperature range  
BI15-CP40-FZ3X2/S100**

**TURCK**

Industrial  
Automation

**Accessories**

Type code	Ident no.	Description	Dimension drawing
STRM M20X1,5 BLACK	6965902	Cable glands M20 x 1.5	
Adjusting bar JS 025/037	69429	Adjusting bar for rectangular housings CK/CP40; material: VA 1.4301	
BSS-CP40	6901318	Mounting bracket for rectangular devices; material: Polypropylene	