

**Inductive sensor  
ring sensor  
BI20R-W30-DAP6X-H1141**

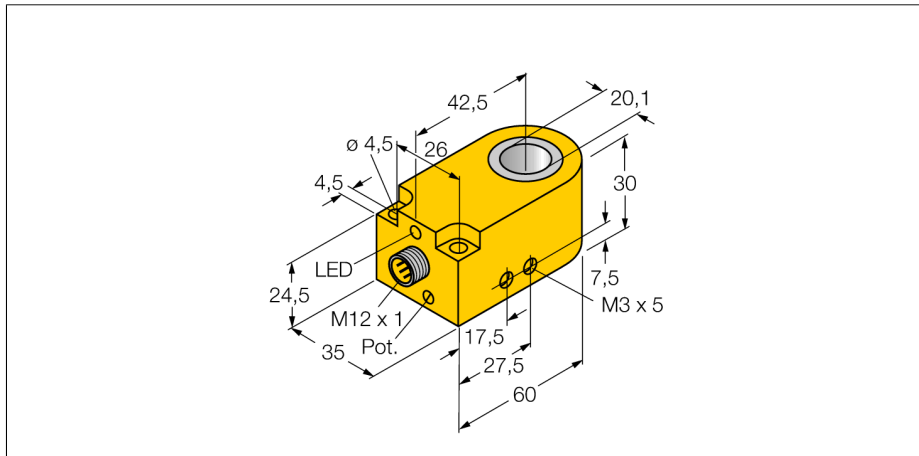

- Rectangular, height 30 mm
- Plastic, PA12-GF30
- Pulse duration 100 ms
- Sensitivity adjusted via potentiometer
- DC 3-wire, 10...30 VDC
- Dynamic output performance
- NO contact, PNP output
- M12 x 1 connector

**Wiring diagram**

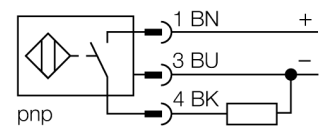

**Functional principle**

Inductive sensors detect metal objects contactless and wear-free. For this purpose they use a high-frequency electromagnetic AC field that interacts with the target. Inductive ring sensors generate this field through an LC resonant circuit. The target acts as the coil core.

**Output performance**

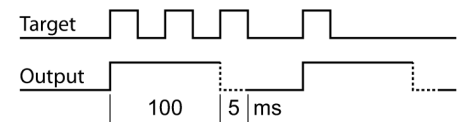

<b>Type code</b>	BI20R-W30-DAP6X-H1141
Ident no.	14042
<b>Inside ring diameter D</b>	20.1 mm
Steel ball diameter (DIN 5401)	≥ 2 mm
Fly-by speed pulse stop	0.1...50 m/s
Pulse duration	≥ 5 ms
Ambient temperature	100 ms ± 20 %
	-25...+70 °C
<b>Operating voltage</b>	10...30VDC
Residual ripple	≤ 10 % U <sub>in</sub>
DC rated operational current	≤ 200 mA
No-load current I <sub>0</sub>	≤ 10 mA
Residual current	≤ 0.1 mA
Rated insulation voltage	≤ 0.5 kV
Short-circuit protection	yes/ cyclic
Voltage drop at I <sub>0</sub>	≤ 2.5 V
Wire breakage / Reverse polarity protection	yes/ complete
Output function	3-wire, NO contact, PNP
Switching frequency	0.008 kHz
<b>Design</b>	ring sensor, W30
Dimensions	60x 35x 30 mm
Housing material	Plastic, PA
Connection	male, M12 x 1
Coil body	plastic, POM
Vibration resistance	55 Hz (1 mm)
Shock resistance	30 g (11 ms)
Protection class	IP67
MTTF	2283 years acc. to SN 29500 (Ed. 99) 40 °C
<b>Switching state</b>	• yellow

**Inductive sensor  
ring sensor  
BI20R-W30-DAP6X-H1141**

---

Distance D	120 mm
Distance W	120 mm
Distance S	20 mm
Distance G	120 mm

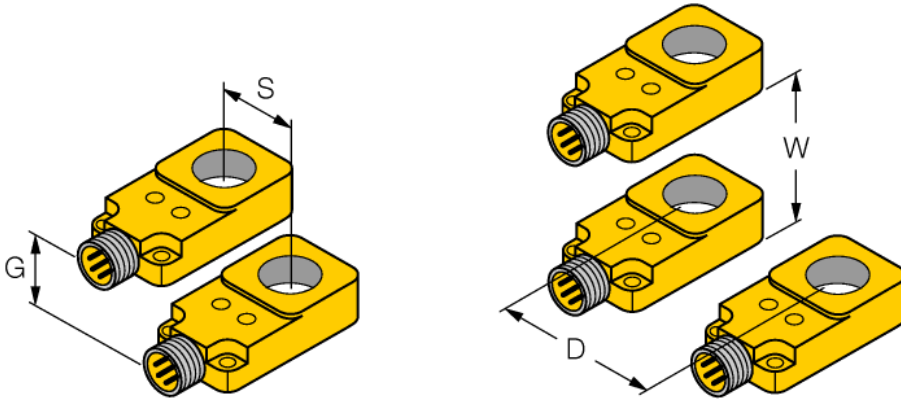

**Inductive sensor  
ring sensor  
BI20R-W30-DAP6X-H1141**

**TURCK**

Industrial  
Automation

**Accessories**

Type code	Ident no.	Description	Dimension drawing
BS-Bi20R-W30	6900401	Fixing clamp for direct mounting on the pipe or tube; clamping ability 19...20 mm; material: POM; included in scope of supply: 1x M4 x 30 (DIN 912-A2); 2x M4 x 35 (DIN 912-A2)	