

Inductive sensor BI10-M30-AD4X

TURCK

Industrial
Automation

- Threaded barrel, M30 x 1.5
- Chrome-plated brass
- DC 2-wire, 10...65 VDC
- NO contact
- Cable connection

Wiring diagram

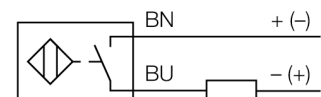

Functional principle

Inductive sensors detect metal objects contactless and wear-free. For this purpose they use a high-frequency electromagnetic AC field that interacts with the target. The sensors hosting a ferrite core coil generate the AC field through an LC resonant circuit.

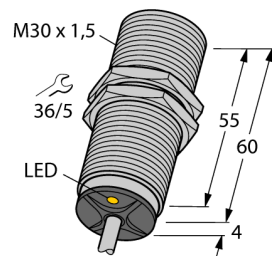

Type code	BI10-M30-AD4X
Ident no.	44170
Rated operating distance Sn	10 mm
Mounting condition	flush
Assured sensing range	$\leq (0,81 \times S_n)$ mm
Correction factors	St37 = 1; Al = 0.3; stainless steel = 0.7; Ms = 0.4
Repeatability	$\leq 2\%$ of full scale
Temperaturdrift	10 %
Hysteresis	1...15 %
Ambient temperature	-25...+70 °C
Operating voltage	10...65VDC
Residual ripple	$\leq 10\% U_{ss}$
DC rated operational current	≤ 100 mA
Residual current	≤ 0.6 mA
Rated insulation voltage	≤ 0.5 kV
Short-circuit protection	yes/ cyclic
Voltage drop at I_n	≤ 5 V
Smallest operating current I_m	≤ 3 mA
Switching frequency	0.5 kHz
Design	threaded barrel, M30 x 1.5
Dimensions	64 mm
Housing material	Metal, CuZn, chrome-plated
Material active face	Plastic, PA
End cap	Plastic, EPTR
Max. tightening torque housing nut	75 Nm
Connection	cable
Cable quality	5.2 mm, LifYY, PVC, 2 m
Cable cross section	2 x 0.34 mm ²
Vibration resistance	55 Hz (1 mm)
Shock resistance	30 g (11 ms)
Protection class	IP67
MTTF	2283 years acc. to SN 29500 (Ed. 99) 40 °C
Switching state	• yellow

**Inductive sensor
BI10-M30-AD4X**

Distance D	2 x B
Distance W	3 x Sn
Distance T	3 x B
Distance S	1.5 x B
Distance G	6 x Sn
<hr/>	
Diameter of the active area B	Ø 30 mm

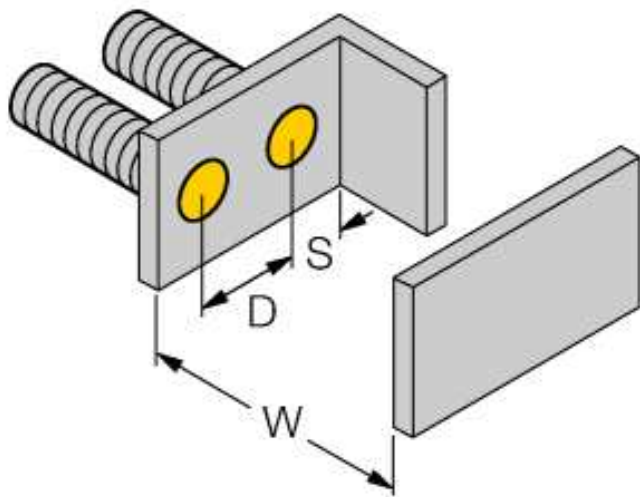
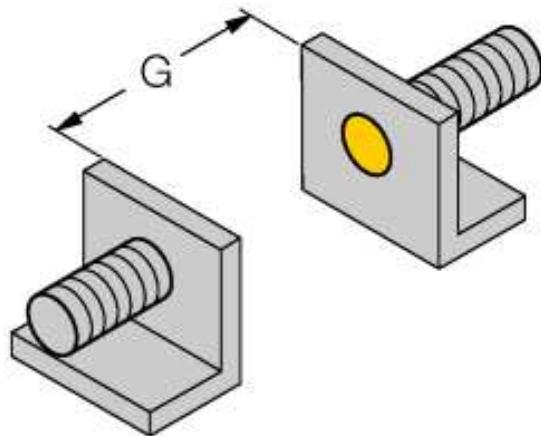
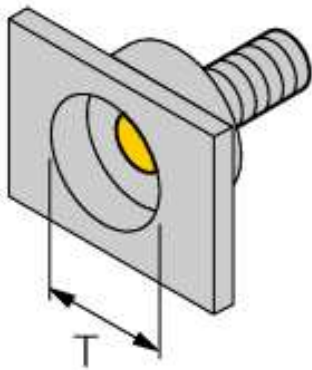

Accessories

Type code	Ident no.	Description	Dimension drawing
BST-30B	6947216	Fixing clamp for threaded barrel devices, with dead-stop; material: PA6	
QM-30	6945103	Quick-mount bracket with dead-stop; material: Chrome-plated brass Male thread M36 x 1.5. Note: The switching distance of proximity switches can be reduced by the use of quick-mount brackets.	
MW-30	6945005	Mounting bracket for threaded barrel devices; material: Stainless steel A2 1.4301 (AISI 304)	
BSS-30	6901319	Mounting bracket for smooth and threaded barrel devices; material: Polypropylene	