

**Inductive sensor
for material recognition
NI100R-S32XL-2LU-H1141/S950**

- Rectangular, height 32 mm
- Plastic, POM
- Analog
- 1x analog output for amplitude evaluation
- 1x analog output for phase evaluation
- M12 x 1 connector

Wiring diagram

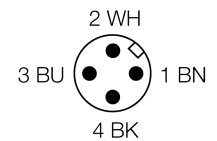
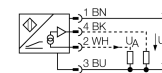

Functional principle

Many applications require a fast detection of material qualities. For example, the sorting of beverage cans made of aluminium or tin, or the differentiation of pipes made of different metals. Turck has developed an analog inductive sensor for this purpose that not only processes the amplitude signal but also the phase signal. Both signals are output as analog values and processed mathematically with a control unit. Different metals are thus detected independent of the distance.

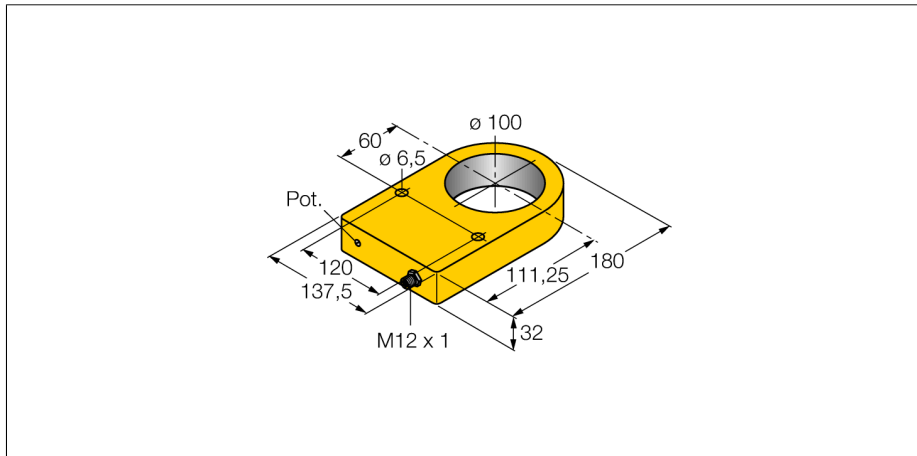

Type code	NI100R-S32XL-2LU-H1141/S950
Ident no.	1534610
Inside ring diameter D	100 mm
Measuring range [A...B]	depending on the length of the cone ≤ 0.5 %, after warm-up 0.5 h
Temperature drift	≤ ± 0.06 % / K
Ambient temperature	-25...+70 °C
Operating voltage	15...30VDC
Residual ripple	≤ 10 % U _s
No-load current I ₀	≤ 8 mA
Rated insulation voltage	≤ 0.5 kV
Short-circuit protection	yes
Wire breakage / Reverse polarity protection	yes/ complete
Output function	4-wire, Analog output
Voltage output	0...10V
Voltage output (phase)	≥ 1...≤ 10VDC
Load resistance voltage output	≥ 4.7 kΩ
Measuring sequence frequency	80 Hz
Design	ring sensor, S32XL
Dimensions	180x 137.5x 32 mm
Housing material	Plastic, POM
Connection	male, M12 x 1
Coil body	plastic, POM
Vibration resistance	55 Hz (1 mm)
Shock resistance	30 g (11 ms)
Protection class	IP67
MTTF	751 years acc. to SN 29500 (Ed. 99) 40 °C

**Inductive sensor
for material recognition
NI100R-S32XL-2LU-H1141/S950**

TURCK

Industrial
Automation

