

**Inductive sensor
for use in vehicle board nets
BI4-EM12E-AP45XLD-H1141**

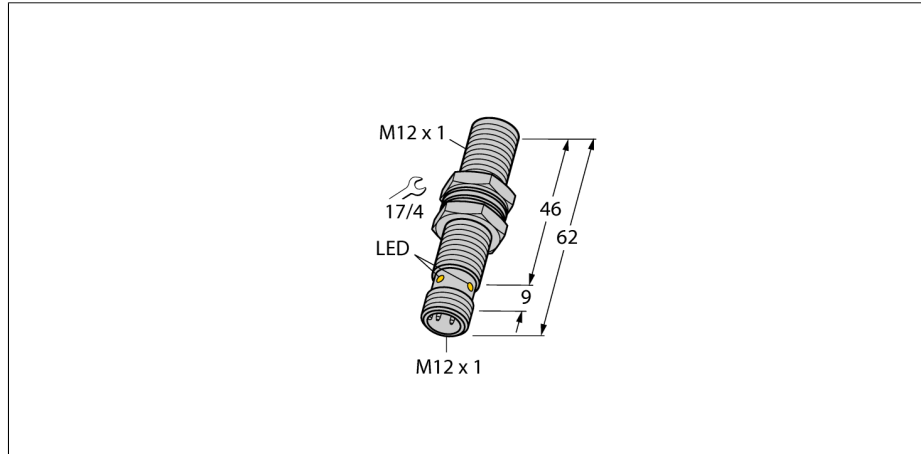

- e1 type approval from German federal office for motor vehicles
- Threaded barrel, M12 x 1
- Stainless steel, 1.4404
- For vehicle board nets, 12 V and 24 V
- Increased interference immunity 100V/m radiated and 100mA BCI
- Load-Dump protection according to DIN 7637 (SAE J 113-11)
- Extended temperature range
- High protection classes IP68/IP69K
- Protection against salt spray and thermal shock
- Laser engraved label, permanently legible
- DC 3-wire, 8.4...65 VDC
- NO contact, PNP output
- M12 x 1 connector

Wiring diagram

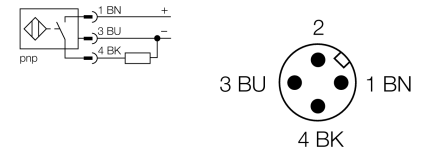

Functional principle

Maximum reliability even under the most extreme environmental conditions is guaranteed by our sensors for mobile applications. TURCK's inductive sensors for extremely hostile industrial environments not only meet, but even exceed the requirements of the protection classes IP68 and IP69.

Applied in vehicles for road construction or in agricultural machines, these sensors excel in high vibration and shock resistance and they withstand fast temperature cycles.

12 V Bordnet						
Impulse	1	2	3a	3b	4	5
Severity level	IV	IV	IV	IV	IV	IV
Failure criterion	C	C	A	A	C	C

24 V Bordnet						
Impulse	1	2	3a	3b	4	5
Severity level	III	IV	IV	IV	III	IV
Failure criterion	C	C	A	A	A	C

Type code	BI4-EM12E-AP45XLD-H1141
Ident no.	1584000
Rated operating distance Sn	4 mm
Mounting condition	flush
Assured sensing range	≤ (0,81 x Sn) mm
Correction factors	St37 = 1; Al = 0.3; stainless steel = 0.7; Ms = 0.4
Repeatability	≤ 2 % of full scale
Temperaturdrift	10 %
Hysteresis	≤ ± 15 %, ≤ -25 °C v ≥ +70 °C
Ambient temperature	3...15 %
Ambient temperature	-40...+85 °C
Temperature changes (EN60068-2-14)	-40... +85 °C; 20 cycles
Operating voltage	8.4...65VDC
Residual ripple	≤ 10 % U _{ss}
DC rated operational current	≤ 200 mA
No-load current I₀	≤ 15 mA
Residual current	≤ 0.1 mA
Rated insulation voltage	≤ 0.5 kV
Short-circuit protection	yes/ cyclic
Voltage drop at I₀	≤ 1.8 V
Wire breakage / Reverse polarity protection	yes/ complete
Output function	3-wire, NO contact, PNP
Load-dump protection (DIN ISO 7637-2)	Severity degree IV / Level 4
Switching frequency	2 kHz
Design	threaded barrel, M12 x 1
Dimensions	62 mm
Housing material	Metal, V4A (1.4404)
Material active face	Plastic, PA
Max. tightening torque housing nut	10 Nm
Connection	male, M12 x 1
Vibration resistance	55 Hz (1 mm)
Vibration resistance (EN 60068-2-6)	20 g; 10...3000 Hz; 50 cycles; 3 axes
Shock resistance	30 g (11 ms)
Shock resistance (EN 60068-2-27)	150 g; 6 ms ½ sinus; each 3x; 3 axes
Continuous shock resistance (EN 60068-2-29)	100 g; 11 ms ½ sinus; each 3x; 3 axes
Salt spray test (EN 60068-2-52)	severity degree 5 (4 test cycles)
Protection class	IP68 / IP69K
MTTF	2283 years acc. to SN 29500 (Ed. 99) 40 °C
Switching state	• yellow

**Inductive sensor
for use in vehicle board nets
BI4-EM12E-AP45XLD-H1141**

Distance D	2 x B
Distance W	3 x Sn
Distance T	3 x B
Distance S	1.5 x B
Distance G	6 x Sn

Diameter of the active area B \varnothing 12 mm

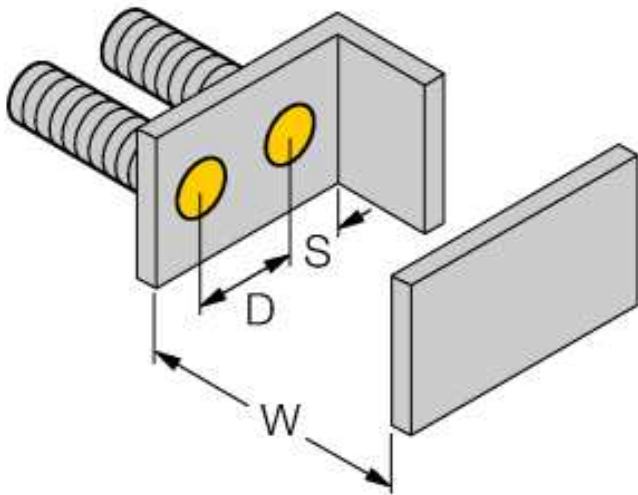
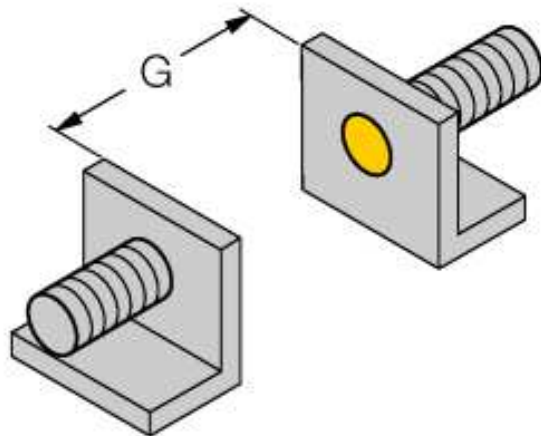
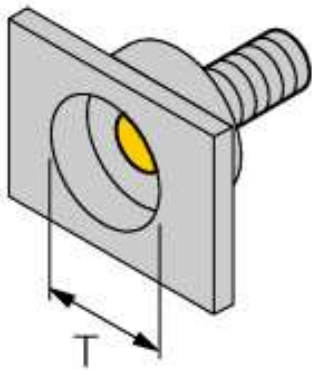

**Inductive sensor
for use in vehicle board nets
BI4-EM12E-AP45XLD-H1141**

Accessories

Type code	Ident no.	Description	Dimension drawing
BST-12B	6947212	Fixing clamp for threaded barrel devices, with dead-stop; material: PA6	
QM-12	6945101	Quick-mount bracket with dead-stop; material: Chrome-plated brass Male thread M16 x 1. Note: The switching distance of proximity switches can be reduced by the use of quick-mount brackets.	
MW-12	6945003	Mounting bracket for threaded barrel devices; material: Stainless steel A2 1.4301 (AISI 304)	
BSS-12	6901321	Mounting bracket for smooth and threaded barrel devices; material: Polypropylene	