

- Threaded barrel, M30 x 1.5
- Chrome-plated brass
- Factor 1 for all metals
- Protection class IP68
- Magnetic field immune
- High switching distance
- Integrated predamping protection
- Limited metal-free spaces
- DC 4-wire, 10...55 VDC
- Changeover contact, PNP output
- M12 x 1 connector

Wiring diagram

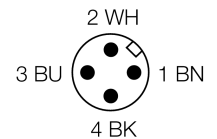
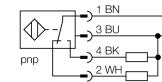

Functional principle

Inductive sensors detect metal objects contactless and wear-free. Due to the patented multi-coil system, *Uprox*®+ sensors have distinct advantages compared to conventional sensors. They excel in highest switching distances, maximum flexibility and operational reliability as well as efficient standardization.

Type	NI30U-M30-VP44X-H1141
Ident-No.	1634887
Rated operating distance Sn	30 mm
Mounting condition	non-flush
Assured sensing range	≤ (0,81 x Sn) mm
Repeatability	≤ 2 %
Temperaturdrift	10 %
	≤ ± 15 %, ≤ -25 °C v ≥ +70 °C
Hysteresis	3...15 %
Ambient temperature	-30...+85 °C
Operating voltage	10...55VDC
Residual ripple	≤ 10 % U _{ss}
DC rated operational current	≤ 200 mA
No-load current I ₀	≤ 20 mA
Residual current	≤ 0.1 mA
Rated insulation voltage	≤ 0.5 kV
Short-circuit protection	yes/ cyclic
Voltage drop at I _e	≤ 1.8 V
Wire breakage / Reverse polarity protection	yes/ complete
Output function	4-wire, changover contact, PNP
Protection class	☐
Switching frequency	1 kHz
Design	threaded barrel, M30 x 1.5
Dimensions	62 mm
Housing material	Metal, CuZn, chrome-plated
Material active face	Plastic, LCP
Max. tightening torque housing nut	75 Nm
Connection	male, M12 x 1
Vibration resistance	55 Hz (1 mm)
Shock resistance	30 g (11 ms)
Protection class	IP68
MTTF	874 years acc. to SN 29500 (Ed. 99) 40 °C
Switching state	LED yellow

Mounting instructions	minimum distances
Distance D	135 mm
Distance W	90 mm
Distance T	90 mm
Distance S	45 mm
Distance G	180 mm
Distance N	30 mm

Diameter of the active area B \varnothing 30 mm

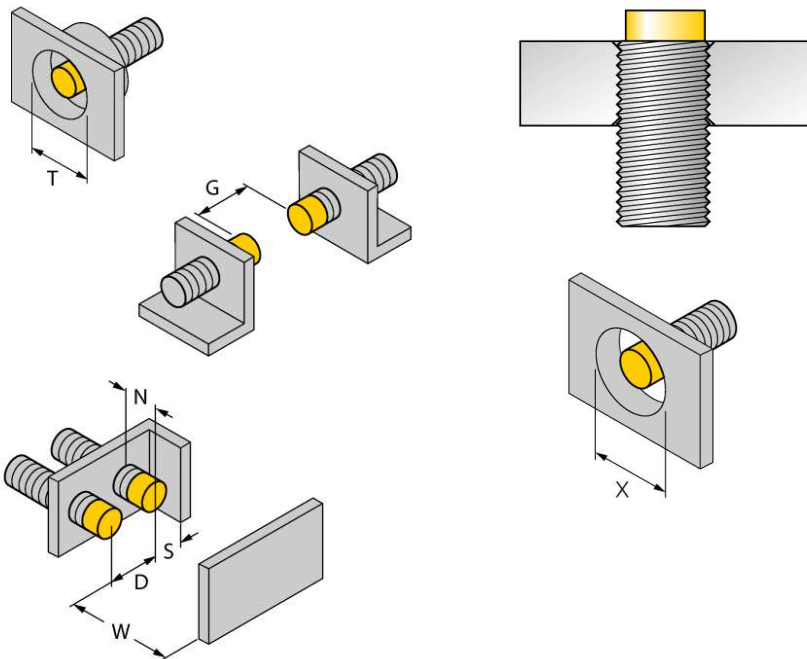

All non-flush mountable *uprox[®]+* threaded barrel sensors can be screwed to the upper edge of the barrel. Thus safe operation is guaranteed with a reduced switching distance of max. 20 %.

When installed in an aperture plate a distance of X = 140 mm must be observed.

Accessories

Type code	Ident-No.		Dimension drawing
BST-30B	6947216	Fixing clamp for threaded barrel devices, with dead-stop; material: PA6	
QM-30	6945103	Quick-mount bracket with dead-stop; material: Chrome-plated brass Male thread M36 x 1.5. Note: The switching distance of proximity switches can be reduced by the use of quick-mount brackets.	
MW-30	6945005	Mounting bracket for threaded barrel devices; material: Stainless steel A2 1.4301 (AISI 304)	
BSS-30	6901319	Mounting bracket for smooth and threaded barrel devices; material: Polypropylene	