

- Threaded barrel, M30 x 1.5
- Chrome-plated brass
- Large monitoring range of 3 to 3000 1/min
- Adjustable via potentiometer
- Fixed start-up delay 5 s
- Magnetic field immune
- DC 3-wire, 10...65 VDC
- NO contact, PNP output
- Cable connection

**Wiring diagram**

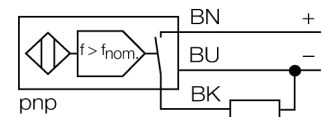

**Functional principle**

The rotational speed is detected by periodic damping of the integrated inductive sensor. This can be accomplished via metal targets or teeth on the monitored shaft. The pulse sequence generated is compared to an adjustable reference value in a comparator circuit. If the rotational speed is below the reference value, the output is switched off (0). If the reference value is exceeded, the output is switched on (1). The start-up time delay (AÜ) is triggered by applying voltage to the device and closes the output for 5 s (start-up time of the drive).

**Diagram**

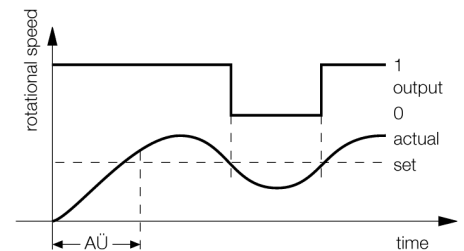

<b>Type code</b>	DNI20U-M30-AP4X2
Ident no.	1582233
<b>Rotational speed range, adjustable</b>	0.05...50Hz adjustable via potentiometer
Hysteresis (rotational-speed range)	3...15%
Rated operating distance $S_n$	20 mm
Mounting condition	non-flush
Assured sensing range	$\leq (0,81 \times S_n)$ mm
Repeatability	$\leq 2\%$ of full scale
Temperaturdrift	10 %
Hysteresis	$\leq \pm 15\%$ , $\leq -25\text{ °C}$ v $\geq +70\text{ °C}$
Ambient temperature	-30...+85 °C
<b>Operating voltage</b>	10...65VDC
Residual ripple	$\leq 10\% U_{s\text{}}$
DC rated operational current	$\leq 200\text{ mA}$
No-load current $I_0$	$\leq 20\text{ mA}$
Residual current	$\leq 0.1\text{ mA}$
Rated insulation voltage	$\leq 0.5\text{ kV}$
Short-circuit protection	yes/ cyclic
Voltage drop at $I_0$	$\leq 1.8\text{ V}$
Wire breakage / Reverse polarity protection	yes/ complete
Output function	3-wire, NO contact, PNP
Protection class	□
<b>Design</b>	threaded barrel, M30 x 1.5
Dimensions	64 mm
Housing material	Metal, CuZn, chrome-plated
Material active face	Plastic, PBT
End cap	Plastic, EPTR
Max. tightening torque housing nut	75 Nm
Connection	cable
Cable quality	5.2 mm, LiYY, PVC, 2 m
Cable cross section	$3 \times 0.34\text{ mm}^2$
Vibration resistance	55 Hz (1 mm)
Shock resistance	30 g (11 ms)
Protection class	IP67
<b>Operating voltage</b>	LED green
Switching state	• green / yellow / blue

**Inductive sensor  
rotational speed monitor  
DNI20U-M30-AP4X2**

Distance D	3 x B
Distance W	3 x Sn
Distance T	3 x B
Distance S	1.5 x B
Distance G	6 x Sn
Distance N	2 x Sn
<hr/>	
Diameter of the active area B	Ø 30 mm

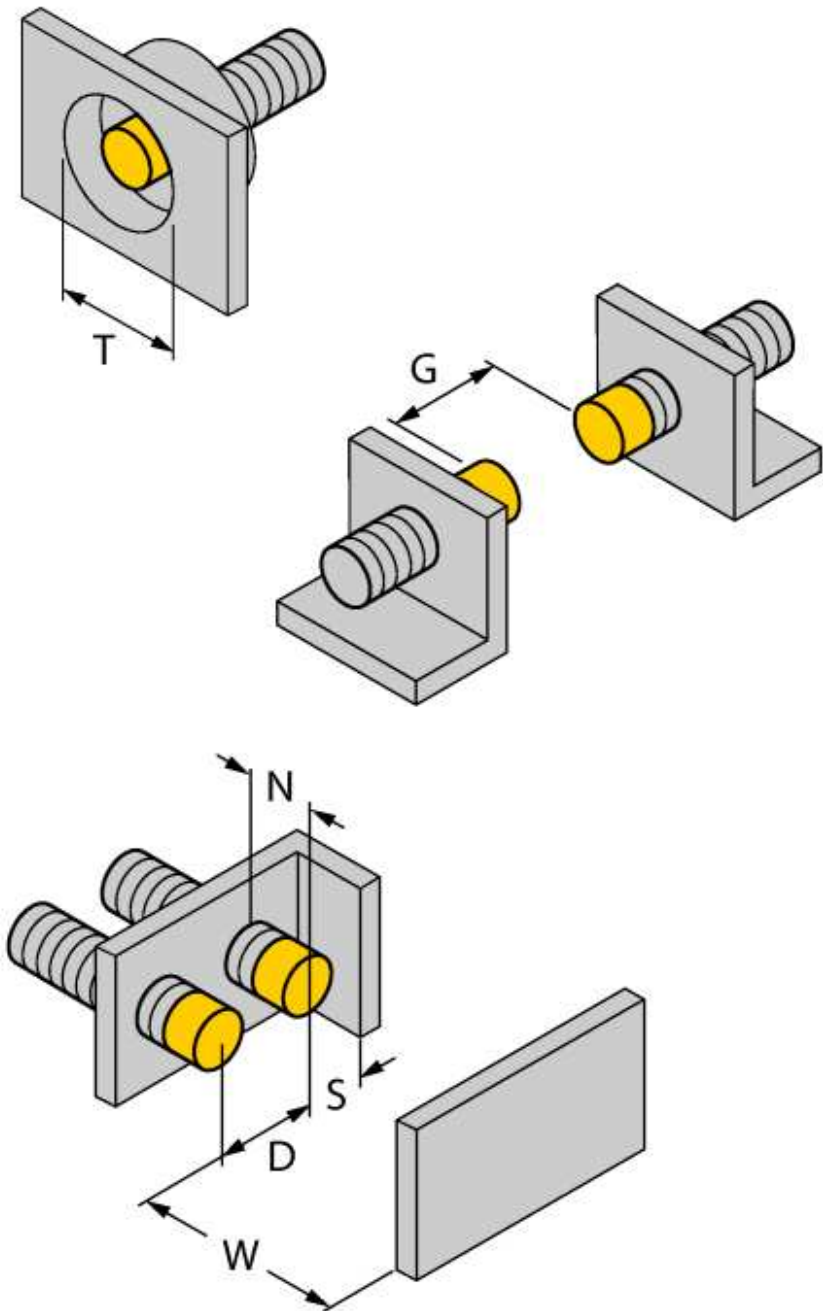

**Accessories**

Type code	Ident no.	Description	Dimension drawing
BST-30B	6947216	Fixing clamp for threaded barrel devices, with dead-stop; material: PA6	
QM-30	6945103	Quick-mount bracket with dead-stop; material: Chrome-plated brass Male thread M36 x 1.5. Note: The switching distance of proximity switches can be reduced by the use of quick-mount brackets.	
MW-30	6945005	Mounting bracket for threaded barrel devices; material: Stainless steel A2 1.4301 (AISI 304)	
BSS-30	6901319	Mounting bracket for smooth and threaded barrel devices; material: Polypropylene	