

# EZ-LIGHT® TL50 High Brightness Tower Light

Multi-Color General-Purpose or Audible Indicators



Standard



Standard Audible



Sealed Audible



Omni-Directional Sealed Audible

- Similar in design and construction to standard TL50 Tower Lights, but more than 4 times brighter, improving visibility in areas with high levels of ambient light.
- Rugged, cost-effective, and easy-to-install multi-segment indicators
- Illuminated segments provide easy-to-see operator guidance and indication of equipment status
- Displays up to 5 colors
- Available in black or light gray housing
- Available models available with standard, sealed, or omni-directional audible element
- Compact devices are completely self-contained - no controller needed
- 18 to 30V dc or 24V ac operation
- No assembly required

## Audible Models

Standard Audible Models <sup>1</sup>			# of LED Colors	LED Function <sup>2</sup>	Connection <sup>3</sup>	Inputs
TL50HRAQ			1	Red	4-pin Euro integral QD connector	Bimodal (NPN or PNP)
TL50HGRAQ			2	Green, Red		
TL50HGYRAQ			3	Green, Yellow, Red	5-pin Euro integral QD connector	
TL50HBGYRAQ			4	Blue, Green, Yellow, Red	8-pin Euro integral QD connector	

Sealed Audible Models <sup>1</sup>			# of LED Colors	LED Function <sup>2</sup>	Connection <sup>3</sup>	Inputs
Continuous	Pulsed at 1.6 Hz	Staccato				
TL50HRALSQ	TL50HRALS3Q	TL50HRALS4Q	1	Red	4-pin Euro integral QD connector	Bimodal (NPN or PNP)
TL50HGRALSQ	TL50HGRALS3Q	TL50HGRALS4Q	2	Green, Red		
TL50HGYRALSQ	TL50HGYRALS3Q	TL50HGYRALS4Q	3	Green, Yellow, Red	5-pin Euro integral QD connector	
TL50HBGYRALSQ	TL50HBGYRALS3Q	TL50HBGYRALS4Q	4	Blue, Green, Yellow, Red	8-pin Euro integral QD connector	

Omni-Directional Sealed Audible Models (sound exits at 45°) <sup>1</sup>			# of LED Colors	LED Function <sup>2</sup>	Connection <sup>3</sup>	Inputs
Continuous	Pulsed at 1.6 Hz	Staccato				
TL50HRAOSQ	TL50HRAOS3Q	TL50HRAOS4Q	1	Red	4-pin Euro integral QD connector	Bimodal (NPN or PNP)
TL50HGRAOSQ	TL50HGRAOS3Q	TL50HGRAOS4Q	2	Green, Red		
TL50HGYRAOSQ	TL50HGYRAOS3Q	TL50HGYRAOS4Q	3	Green, Yellow, Red	5-pin Euro integral QD connector	
TL50HBGYRAOSQ	TL50HBGYRAOS3Q	TL50HBGYRAOS4Q	4	Blue, Green, Yellow, Red	8-pin Euro integral QD connector	



NOTE: Non-Audible Models are listed on the next page.

<sup>1</sup> Models with black housing are listed. For gray housing, add suffix **C** at the end of the model number (cabled models) or before the **Q** (QD models), for example, **TL50HRC** or **TL50HRCQ**.

<sup>2</sup> The first color listed is the bottom color, going up in successive order. Contact the factory for other colors and color combinations

<sup>3</sup> Integral QD models only are listed; mating cordset required (see [Cordsets](#) on page 4).

- For 150 mm (5.9 in) PVC pigtail with QD, replace **Q** with **QP** in the model number, for example, **TL50HRQP**.
- For 2 m (6.5 ft) cable, omit suffix **Q** from the model number, for example, **TL50HR**.

## Non-Audible Models

Model <sup>4</sup>	# of LED Colors	LED Function <sup>5</sup>	Connection <sup>6</sup>	Inputs
TL50HRQ	1	Red	4-pin Euro integral QD connector	Bimodal (NPN or PNP)
TL50HGRQ	2	Green, Red		
TL50HGYRQ	3	Green, Yellow, Red		
TL50HBGYRQ	4	Blue, Green, Yellow, Red	5-pin Euro integral QD connector	
TL50HWBGYRQ	5	White, Blue, Green, Yellow, Red	8-pin Euro integral QD connector	

## Specifications

### Supply Voltage and Current

18 to 30V dc (10% max. ripple); or 21 to 27V ac

**Indicators** - max. current per LED color:

- at 18V dc: 100 mA
- at 30V dc: 60 mA
- at 21V ac: 80 mA
- at 27V ac: 70 mA

**Standard Audible Alarm:** 25 mA max. current

**Sealed Audible Alarm:** 35 mA max. current

**Omni-Directional Sealed Audible Alarm:** 45 mA max. current

### Indicators

1 to 5 colors; Green, Red, Yellow, Blue, White;  
LEDs are independently selected

### Supply Protection Circuitry:

Protected against reverse polarity and transient voltages

### Input Response Time

**Indicator ON/OFF:** 10 ms (max.)

### Audible Adjustment

**Standard Audible Alarm:** Unscrew the cover (up to 1.5 turns max.) to adjust the audible intensity. (Do not exceed 1.5 turns or the cover may detach during operation.) For max. intensity, rotate the center plug 180° counterclockwise to remove it.

**Sealed Audible Alarm:** Rotate the front cover until the desired intensity is reached.

**Omni-Directional Sealed Audible Alarm:** No adjustment.

### Vibration and Mechanical Shock:

All models meet Mil. Std. 202F requirements method 201A (vibration: 10 to 60 Hz max., double amplitude 0.06 in, maximum acceleration 10G). Also meets IEC 947-5-2; 30G 11 ms duration, half sine wave.

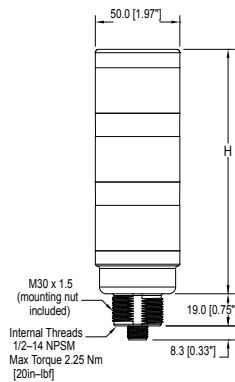

### Connections

Integral 4-pin, 5-pin, or 8-pin M12/Euro-style QD, 150 mm (5.9 in) PVC pigtail with QD, or 2 m (6.5 ft) integral cable, depending on model

### Operating Conditions:

**Non-Audible:** -40° to +50° C (-40° to +122° F)

**Standard and Sealed Audible:** -20° to +50° C (-4° to +122° F)

**Max. Rel. Humidity:** 95% at 50° C (non-condensing)

### Audible Alarm

Audible measurements are made in the direction sound exits the device. For standard audible models, this is the top of the unit (when mounted vertically, sound is directed toward the ceiling). For sealed audible models, sound exits the vented openings in the side of the unit, which should be oriented so that the sound is directed toward the machine operator(s). In environments with high ambient noise levels or high ceilings that absorb sound, the sealed or omni-directional models are recommended.

**Standard Audible Alarm:** 2.7 KHz ± 500 Hz oscillation frequency; max. intensity 92 db at 1 m (3.3 ft) (typical)

**Sealed Audible Alarm:** 2.9 KHz ± 250 Hz oscillation frequency; max. intensity 94 db at 1 m (3.3 ft) (typical)

**Omni-Directional Sealed Audible Alarm:** 2.1 KHz ± 250 Hz oscillation frequency; max intensity 99 db at 1m (3.3 ft) (typical)

### Construction:

**Bases and Covers:** ABS

**Light Segment:** Polycarbonate

### Environmental Rating

**Non-Audible and Sealed Audibles:** IEC IP67

**Standard Audible:** IEC IP50

### Certifications

 **Omni-Directional models:** pending

# of Colors	Tower Height (H)			
	Non-Audible	Standard Audible*	Sealed Audible	Omni-Directional Sealed Audible
1	61.2 mm (2.4 in)	92.0 mm (3.6 in)	115.1 mm (4.5 in)	129.1 mm (5.1 in)
2	101.9 mm (4.0 in)	132.7 mm (5.2 in)	155.8 mm (6.1 in)	169.8 mm (6.7 in)
3	142.6 mm (5.6 in)	173.4 mm (6.8 in)	196.5 mm (7.7 in)	210.5 mm (8.3 in)
4	183.3 mm (7.2 in)	214.1 mm (8.4 in)	237.2 mm (9.3 in)	251.2 mm (9.9 in)
5	224.0 mm (8.8 in)	-	-	-

\* Tower height (H) with top unscrewed approximately 3.5 mm to allow sound to escape

<sup>4</sup> Models with black housing are listed. For gray housing, add suffix **C** at the end of the model number (cabled models) or before the **Q** (QD models), for example, **TL50HRC** or **TL50HRQC**.

<sup>5</sup> The first color listed is the bottom color, going up in successive order. Contact the factory for other colors and color combinations

<sup>6</sup> Integral QD models only are listed; mating cordset required (see [Cordsets](#) on page 4).

- For 150 mm (5.9 in) PVC pigtail with QD, replace **Q** with **QP** in the model number, for example, **TL50HRQP**.
- For 2 m (6.5 ft) cable, omit suffix **Q** from the model number, for example, **TL50HR**.

## Hookups – 4-Pin Models

Sourcing (PNP) Input

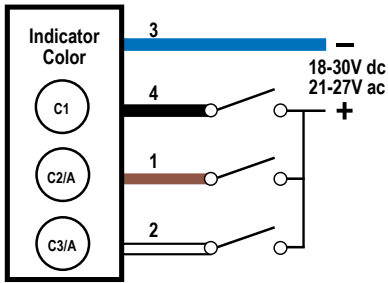

Sinking (NPN) Input

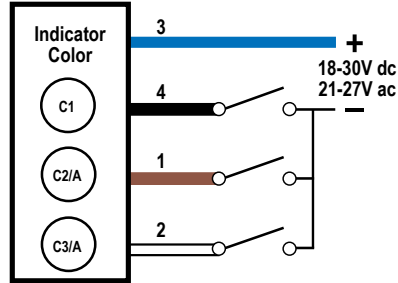

Key:

- |           |              |
|-----------|--------------|
| 1 = Brown | C1 = Color 1 |
| 2 = White | C2 = Color 2 |
| 3 = Blue  | C3 = Color 3 |
| 4 = Black | A = Audible  |

Pins 1 and 2 could activate the corresponding color or the audible function, if available.

## Hookups – 5-Pin Models

Sourcing (PNP) Input

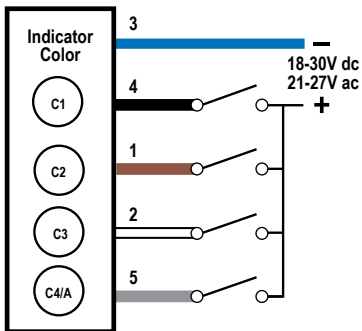

Sinking (NPN) Input

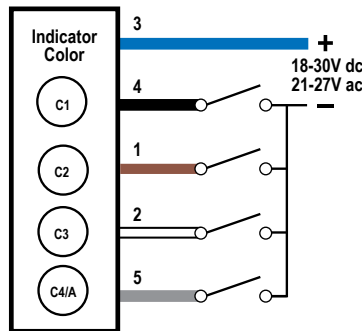

Key:

- |           |              |
|-----------|--------------|
| 1 = Brown | C1 = Color 1 |
| 2 = White | C2 = Color 2 |
| 3 = Blue  | C3 = Color 3 |
| 4 = Black | C4 = Color 4 |
| 5 = Gray  | A = Audible  |

Pin 5 could activate the corresponding color or the audible function, if available.

## Hookups – 8-Pin Models

Sourcing (PNP) Input

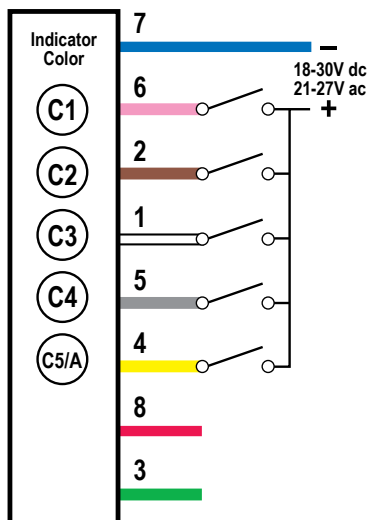

Sinking (NPN) Input

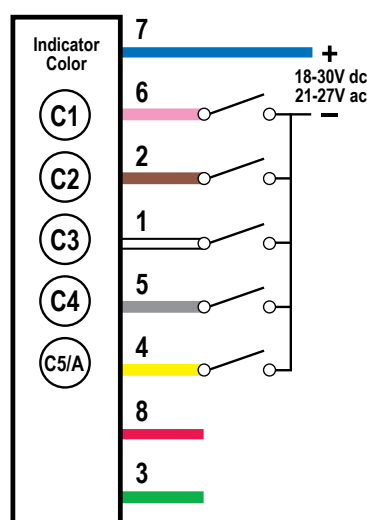

Key:

- |            |              |
|------------|--------------|
| 1 = White  | C1 = Color 1 |
| 2 = Brown  | C2 = Color 2 |
| 3 = Green  | C3 = Color 3 |
| 4 = Yellow | C4 = Color 4 |
| 5 = Gray   | C5 = Color 5 |
| 6 = Pink   | A = Audible  |
| 7 = Blue   |              |
| 8 = Red    |              |

Pin 4 could activate the corresponding color or the audible function, if available. Pins 3 and 8 are not used.

## Accessories

### Cordsets

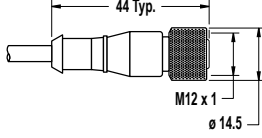
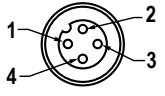
4-Pin Threaded M12/Euro-Style Cordsets				
Model	Length	Style	Dimensions	Pinout
MQDC-406	1.83 m (6 ft)	Straight		 <p>1 = Brown 2 = White 3 = Blue 4 = Black</p>
MQDC-415	4.57 m (15 ft)			
MQDC-430	9.14 m (30 ft)			
MQDC-450	15.2 m (50 ft)			

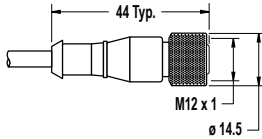
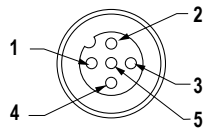
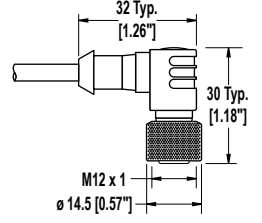
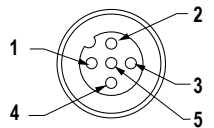
5-Pin Threaded M12/Euro-Style Cordsets (Single Ended)				
Model	Length	Style	Dimensions	Pinout (Female)
MQDC1-501.5	0.50 m (1.5 ft)	Straight		 <p>1 = Brown 2 = White 3 = Blue 4 = Black 5 = Gray</p>
MQDC1-506	1.83 m (6 ft)			
MQDC1-515	4.57 m (15 ft)			
MQDC1-530	9.14 m (30 ft)			
MQDC1-506RA	1.83 m (6 ft)	Right-Angle		 <p>1 = Brown 2 = White 3 = Blue 4 = Black 5 = Gray</p>
MQDC1-515RA	4.57 m (15 ft)			
MQDC1-530RA	9.14 m (30 ft)			

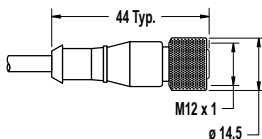
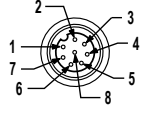
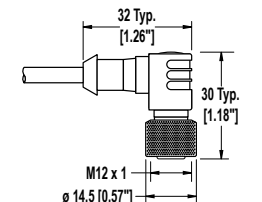
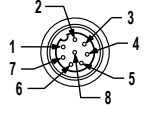
8-Pin Threaded M12/Euro-Style Cordsets with Open-Shield				
Model	Length	Style	Dimensions	Pinout
MQDC2S-806	1.83 m (6 ft)	Straight		 <p>1 = White 2 = Brown 3 = Green 4 = Yellow 5 = Gray 6 = Pink 7 = Blue 8 = Red</p>
MQDC2S-815	4.57 m (15 ft)			
MQDC2S-830	9.14 m (30 ft)			
MQDC2S-850	15.2 m (50 ft)			
MQDC2S-806RA	1.83 m (6 ft)	Right-Angle		 <p>1 = White 2 = Brown 3 = Green 4 = Yellow 5 = Gray 6 = Pink 7 = Blue 8 = Red</p>
MQDC2S-815RA	4.57 m (15 ft)			
MQDC2S-830RA	9.14 m (30 ft)			
MQDC2S-850RA	15.2 m (50 ft)			

## Mounting Brackets

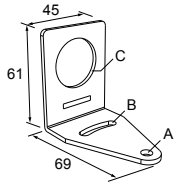
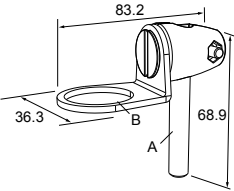
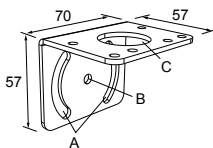
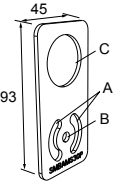
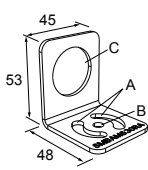
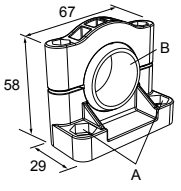

All measurements are in mm

<p><b>SMB30A</b></p> <ul style="list-style-type: none"> <li>• Right-angle bracket with curved slot for versatile orientation</li> <li>• Clearance for M6 (¼ in) hardware</li> <li>• Mounting hole for 30 mm sensor</li> <li>• 12-ga. stainless steel</li> </ul>  <p><b>Hole center spacing:</b> A to B=40  <b>Hole size:</b> A=∅ 6.3, B= 27.1 x 6.3, C=∅ 30.5</p>	<p><b>SMB30FA</b></p> <ul style="list-style-type: none"> <li>• Swivel bracket with tilt and pan movement for precise adjustment</li> <li>• Mounting hole for 30 mm sensor</li> <li>• 12-ga. 304 stainless steel</li> <li>• Easy sensor mounting to extrude rail T-slot</li> <li>• Metric and inch size bolt available</li> </ul>  <p><b>Bolt thread:</b> SMB30FA, A= 3/8 - 16 x 2 in; SMB30FAM10, A= M10 - 1.5 x 50  <b>Hole size:</b> B= ∅ 30.1</p>
<p><b>SMB30MM</b></p> <ul style="list-style-type: none"> <li>• 12-ga. stainless steel bracket with curved mounting slots for versatile orientation</li> <li>• Clearance for M6 (¼ in) hardware</li> <li>• Mounting hole for 30 mm sensor</li> </ul>  <p><b>Hole center spacing:</b> A = 51, A to B = 25.4  <b>Hole size:</b> A = 42.6 x 7, B = ∅ 6.4, C = ∅ 30.1</p>	<p><b>SMBAMS30P</b></p> <ul style="list-style-type: none"> <li>• Flat SMBAMS series bracket</li> <li>• 30 mm hole for mounting sensors</li> <li>• Articulation slots for 90°+ rotation</li> <li>• 12-ga. 300 series stainless steel</li> </ul>  <p><b>Hole center spacing:</b> A=26.0, A to B=13.0  <b>Hole size:</b> A=26.8 x 7.0, B=∅ 6.5, C=∅ 31.0</p>
<p><b>SMBAMS30RA</b></p> <ul style="list-style-type: none"> <li>• Right-angle SMBAMS series bracket</li> <li>• 30 mm hole for mounting sensors</li> <li>• Articulation slots for 90°+ rotation</li> <li>• 12-ga. (2.6 mm) cold-rolled steel</li> </ul>  <p><b>Hole center spacing:</b> A=26.0, A to B=13.0  <b>Hole size:</b> A=26.8 x 7.0, B=∅ 6.5, C=∅ 31.0</p>	<p><b>SMB30SC</b></p> <ul style="list-style-type: none"> <li>• Swivel bracket with 30 mm mounting hole for sensor</li> <li>• Black reinforced thermoplastic polyester</li> <li>• Stainless steel mounting and swivel locking hardware included</li> </ul>  <p><b>Hole center spacing:</b> A=∅ 50.8  <b>Hole size:</b> A=∅ 7.0, B=∅ 30.0</p>

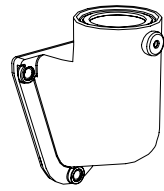
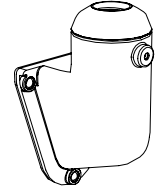
## LMB Sealed Right-Angle Bracket

Model	Description	Construction	
LMB30RA	<b>Direct-Mount Models:</b> Bracket kit with base, 30 mm adapter, set screw, fasteners, o-rings, and gaskets	Black polycarbonate	
LMB30RAC		Gray polycarbonate	
LMBE12RA	<b>Pipe-Mount Models:</b> Bracket kit with base, ½-14 pipe adapter, set screw, fasteners, o-rings, and gaskets. For use with stand-off pipe (listed and sold separately)	Black polycarbonate	
LMBE12RAC		Gray polycarbonate	

## Elevated Mount System

Model			Features	Components
SA-M30TE12 - Black Acetal			<ul style="list-style-type: none"> <li>Streamlined black acetal or white UHMW stand-off pipe adapter/cover</li> <li>Connects between 30 mm light base and ½ in. NPSM/DN15 pipe</li> <li>Mounting hardware included</li> </ul>	
SA-M30TE12C - White UHMW				
Polished 304 Stainless Steel	Black Anodized Aluminum	Clear Anodized Aluminum	<ul style="list-style-type: none"> <li>Elevated-use stand-off pipe (½ in. NPSM/DN15)</li> <li>Polished 304 stainless steel, black anodized aluminum, or clear anodized aluminum surface</li> <li>½ in. NPT thread at both ends</li> <li>Compatible with most industrial environments</li> </ul>	
SOP-E12-150SS 150 mm (6 in) long	SOP-E12-150A 150 mm (6 in) long	SOP-E12-150AC 150 mm (6 in) long		
SOP-E12-300SS 300 mm (12 in) long	SOP-E12-300A 300 mm (12 in) long	SOP-E12-300AC 300 mm (12 in) long		
SOP-E12-900SS 900 mm (36 in) long	SOP-E12-900A 900 mm (36 in) long	SOP-E12-900AC 900 mm (36 in) long		
SA-E12M30 - Black Acetal			<ul style="list-style-type: none"> <li>Streamlined black acetal or white UHMW mounting base adapter/cover</li> <li>Connects between ½ in. NPSM/DN15 pipe and 30 mm (1-3/16 in) drilled hole</li> <li>Mounting hardware included</li> </ul>	
SA-E12M30C - White UHMW				

## Banner Engineering Corp Limited Warranty

Banner Engineering Corp. warrants its products to be free from defects in material and workmanship for one year following the date of shipment. Banner Engineering Corp. will repair or replace, free of charge, any product of its manufacture which, at the time it is returned to the factory, is found to have been defective during the warranty period. This warranty does not cover damage or liability for misuse, abuse, or the improper application or installation of the Banner product.

**THIS LIMITED WARRANTY IS EXCLUSIVE AND IN LIEU OF ALL OTHER WARRANTIES WHETHER EXPRESS OR IMPLIED (INCLUDING, WITHOUT LIMITATION, ANY WARRANTY OF MERCHANTABILITY OR FITNESS FOR A PARTICULAR PURPOSE), AND WHETHER ARISING UNDER COURSE OF PERFORMANCE, COURSE OF DEALING OR TRADE USAGE.**

This Warranty is exclusive and limited to repair or, at the discretion of Banner Engineering Corp., replacement. **IN NO EVENT SHALL BANNER ENGINEERING CORP. BE LIABLE TO BUYER OR ANY OTHER PERSON OR ENTITY FOR ANY EXTRA COSTS, EXPENSES, LOSSES, LOSS OF PROFITS, OR ANY INCIDENTAL, CONSEQUENTIAL OR SPECIAL DAMAGES RESULTING FROM ANY PRODUCT DEFECT OR FROM THE USE OR INABILITY TO USE THE PRODUCT, WHETHER ARISING IN CONTRACT OR WARRANTY, STATUTE, TORT, STRICT LIABILITY, NEGLIGENCE, OR OTHERWISE.**

Banner Engineering Corp. reserves the right to change, modify or improve the design of the product without assuming any obligations or liabilities relating to any product previously manufactured by Banner Engineering Corp.