

**Gateway for BL20 I/O system
interface for EtherNet/IP supply inclusive
BL20-E-GW-EN-IP**

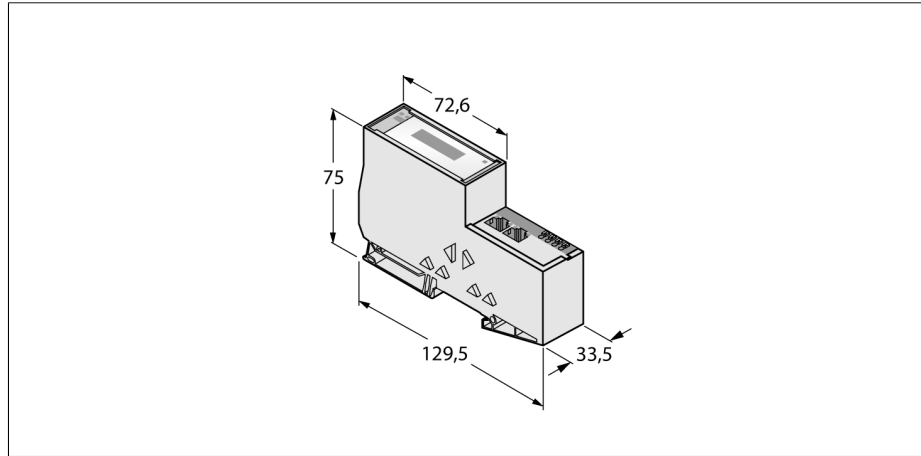

- DIP switch for adjustment of the node address
- Protection class IP20
- 2 x end brackets BL20-WEW35/2-SW
- 1 x end plate BL20-ABPL
- Integrated power supply
- LEDs for display of supply voltage, group and bus errors
- Interface between the BL20 system and EtherNet/IP
- 10/100 Mbps
- Integrated switch
- 2x RJ45 hookup

Type	BL20-E-GW-EN-IP
Ident-No.	6827330
Supply voltage	24VDC
System power supply	24 VDC / 5 VDC
Field supply	24 VDC
Admissible range	18...30 VDC
Rated current from module bus	≤ 200 mA
Max. field supply current	8 A
Max. system supply current	0.4 A
Voltage supply connection	Push-in clamps
Fieldbus transmission rate	10/100 Mbps
Fieldbus addressing	per DIP switch
Fieldbus connection technology	RJ45 socket
Service interface	Mini USB
Dimensions (W x L x H)	33.5x129.5x74.4mm
Approvals	CE, cULus, zone2, ClassI, div.2.
Operating temperature	0 ... +55 °C
Storage temperature	-25 ... +85 °C
Relative humidity	5 to 95% (internal), Level RH-2, no condensation (at 45 °C storage)
Vibration test	acc. to EN 61131
Shock test	acc. to IEC 68-2-27
Drop and topple	acc. to IEC 68-2-31 and free fall to IEC 68-2-32
Electro-magnetic compatibility	acc. to EN 50,082-2
Protection class	IP20
Included in scope of supply	2 x end brackets BL20-WEW-35/2-SW, 1 x end plate BL20-ABPL

Field supply/system supply

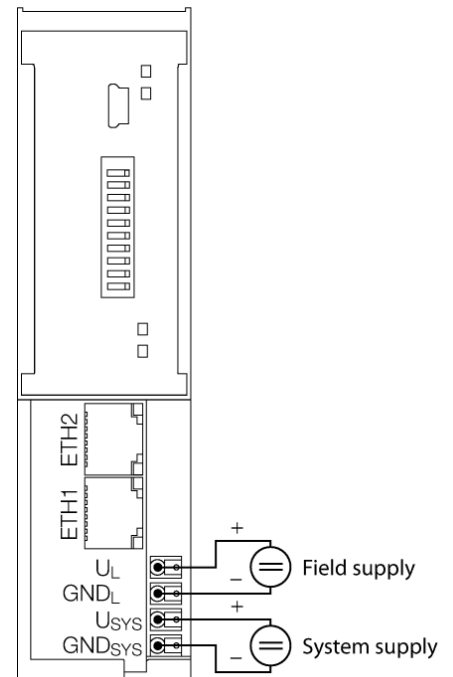

Functional principle

BL20 gateways are the head component of a BL20 station. They are designed to interface the modular fieldbus nodes to the higher level fieldbus (PROFIBUS-DP, DeviceNet, CANopen, Ethernet).

All BL20 electronic modules communicate over the internal module bus, the data of which is transferred to the fieldbus via the gateway, so that all I/O modules can be configured independently of the bus system.