

Gateway for BL67 I/O system
Interface for EtherNet/IP™
BL67-GW-EN-IP

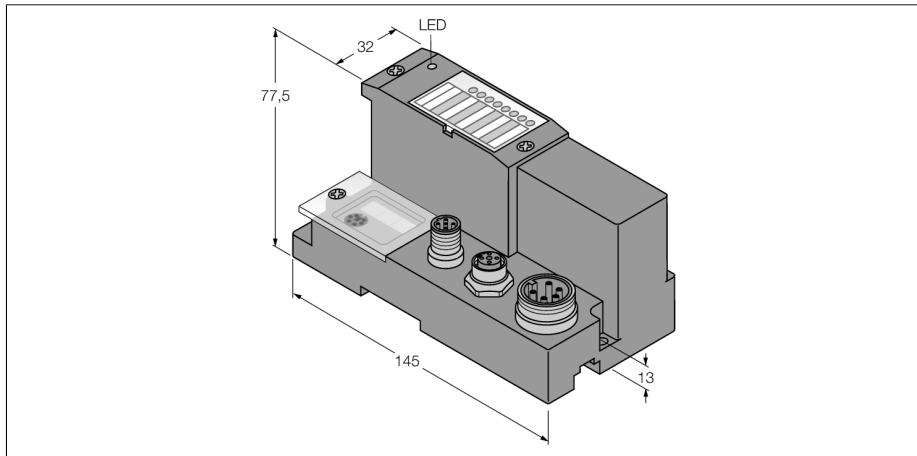

- 3 decimal rotary coding switches
- Protection class IP67
- LEDs for display of supply voltage, group and bus errors
- Interface between the BL67 system and EtherNet/IP
- 10/100 Mbps
- One 4-pin M12 male D-coded for fieldbus connection
- One male 7/8", 5-pin, for power supply

Functional principle

BL67 gateways are the head component of a BL67 station. They are designed to connect the modular fieldbus nodes to the higher level fieldbus (PROFIBUS-DP, DeviceNet™, CANopen, Ethernet Modbus TCP, PROFINET IO or EtherNet/IP™).

All BL67 electronic modules communicate over the internal module bus, the data of which is transferred to the fieldbus via the gateway. All I/O modules can thus be configured independently of the bus system.

Type	BL67-GW-EN-IP
Ident-No.	6827229
Supply voltage	24 VDC
Admissible range	18...30 VDC
Rated current from module bus	≤ 600 mA
max. sensor supply I_{sens}	4 A electronically limited current supply
Max. load current I_L	10 A
Fieldbus transmission rate	10/100 Mbps
Fieldbus addressing	rotary switch, BOOTP, DHCP, IO-ASSISTANT
Fieldbus connection technology	Female connector, M12 x 1, 4-pole, D-coded
Input process image	128 words
Output process image	128 words
Service interface	RS232 interface (PS/2 socket)
Dimensions (W x L x H)	74x145x77.5mm
Approvals	CE, cULus
Operating temperature	-40...+70 °C
Temperature derating	
> 55 °C Circulating air (Ventilation)	no limitation
> 55 °C Steady ambient air	$I_{sens} < 3A, I_{mb} < 1A$
Storage temperature	-40 ... +85 °C
Relative humidity	5 to 95% (internal), Level RH-2, no condensation (at 45 °C storage)
Vibration test	acc. to EN 61131
Extended vibration resistance	VN 02-00 and higher
- up to 5 g (at 10 to 150 Hz)	For mounting on DIN rail no drilling according to EN 60715, with end bracket
- up to 20 g (at 10 to 150 Hz)	For mounting on base plate or machinery Therefore every second module has to be mounted with two screws each.
Shock test	acc. to IEC 68-2-27
Drop and topple	acc. to IEC 68-2-31 and free fall to IEC 68-2-32
Electro-magnetic compatibility	acc. to EN 61131-2
Protection class	IP67
DIN rail mounting	yes, Attention: Offset
Direct mounting	Two mounting holes, 6 mm Ø

Gateway for BL67 I/O system
Interface for EtherNet/IP™
BL67-GW-EN-IP

Pin configuration and supply concept

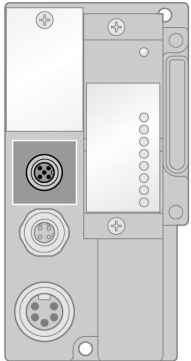
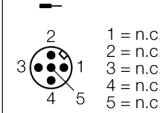
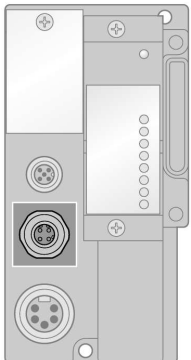
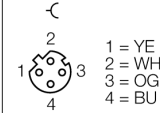
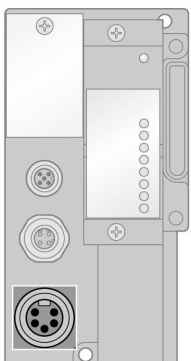
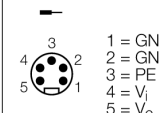
	<p>Not assigned</p>	<p>Pin assignment</p>  <p>1 = n.c. 2 = n.c. 3 = n.c. 4 = n.c. 5 = n.c.</p>
	<p>EtherNet/IP™ slave The M12-D coded Ethernet port is used as interface for configuration and fieldbus communication. The gateway can be operated as a slave at Plus or PC based systems with EtherNet/IP™ scanner (master).</p>	<p>Pin assignment</p>  <p>1 = YE (TX+) 2 = WH (RX+) 3 = OG (TX-) 4 = BU (RX-)</p>
	<p>Power supply Double-tuned power supply of the BL67 system.</p> <p>System power supply V_i V_i is for the internal system supply at the backplane bus ($V_{MB(SV)}$) and for the 4A short-circuit limited sensor supply (V_{sens}).</p> <p>Load voltage V_o V_o for output supply, limited to max. 10A.</p>	<p>Pin assignment</p>  <p>1 = GND 2 = GND 3 = PE 4 = V_i 5 = V_o</p>