



5V 128K X 8 CMOS SRAM

**Features**

- Industrial and commercial temperatures
- Organization: 131,072 words x 8 bits
- High speed
  - 10/12/15/20 ns address access time
  - 5/6/7/8 ns output enable access time
- Low power consumption: ACTIVE
  - 605 mW / max @ 10 ns
- Low power consumption: STANDBY
  - 55 mW / max CMOS
- 6T 0.18u CMOS technology
- Easy memory expansion with  $\overline{CE1}$ ,  $\overline{CE2}$ ,  $\overline{OE}$  inputs
- TTL/LVTTL-compatible, three-state I/O
- 32-pin JEDEC standard packages

- 300 mil SOJ
- 400 mil SOJ
- 8 x 20mm TSOP 1
- 8 x 13.4mm sTSOP 1
- ESD protection  $\geq$  2000 volts
- Latch-up current  $\geq$  200 mA

**Logic block diagram**

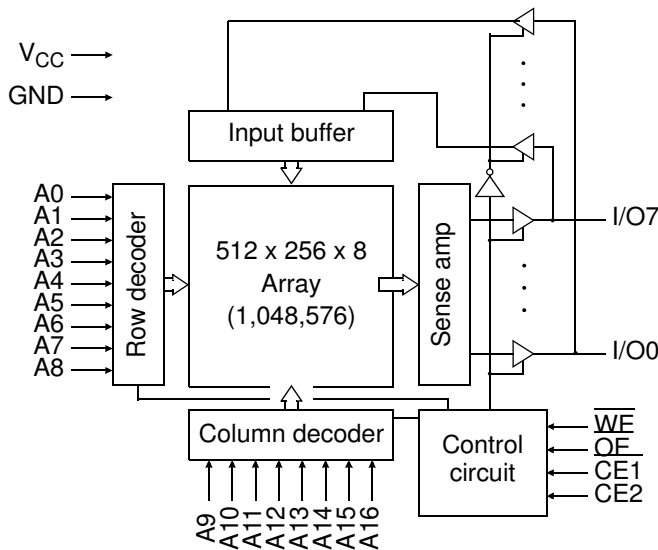

**Pin arrangement**

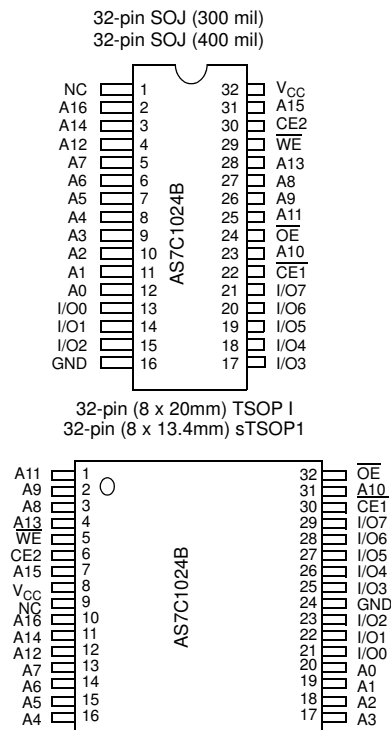

**Selection guide**

	-10	-12	-15	-20	Unit
Maximum address access time	10	12	15	20	ns
Maximum output enable access time	5	6	7	8	ns
Maximum Operating Current	110	100	90	80	mA
Maximum CMOS standby Current	10	10	10	10	mA



## Functional description

The AS7C1024B is a high performance CMOS 1,048,576-bit Static Random Access Memory (SRAM) device organized as 131,072 words x 8 bits. It is designed for memory applications where fast data access, low power, and simple interfacing are desired.

Equal address access and cycle times ( $t_{AA}$ ,  $t_{RC}$ ,  $t_{WC}$ ) of 10/12/15/20 ns with output enable access times ( $t_{OE}$ ) of 5/6/7/8 ns are ideal for high performance applications. Active high and low chip enables ( $\overline{CE1}$ , CE2) permit easy memory expansion with multiple-bank systems.

When  $\overline{CE1}$  is high or CE2 is low, the devices enter standby mode. If inputs are still toggling, the device will consume  $I_{SB}$  power. If the bus is static, then full standby power is reached ( $I_{SB1}$ ). For example, the AS7C1024B is guaranteed not to exceed 55 mW under nominal full standby conditions.

A write cycle is accomplished by asserting write enable ( $\overline{WE}$ ) and both chip enables ( $\overline{CE1}$ , CE2). Data on the input pins I/O0 through I/O7 is written on the rising edge of  $\overline{WE}$  (write cycle 1) or the active-to-inactive edge of  $\overline{CE1}$  or CE2 (write cycle 2). To avoid bus contention, external devices should drive I/O pins only after outputs have been disabled with output enable ( $\overline{OE}$ ) or write enable ( $\overline{WE}$ ).

A read cycle is accomplished by asserting output enable ( $\overline{OE}$ ) and both chip enables ( $\overline{CE1}$ , CE2), with write enable ( $\overline{WE}$ ) high. The chips drive I/O pins with the data word referenced by the input address. When either chip enable is inactive, output enable is inactive, or write enable is active, output drivers stay in high-impedance mode.

## Absolute maximum ratings

Parameter	Symbol	Min	Max	Unit
Voltage on $V_{CC}$ relative to GND	$V_{t1}$	-0.50	+7.0	V
Voltage on any pin relative to GND	$V_{t2}$	-0.50	$V_{CC} + 0.50$	V
Power dissipation	$P_D$	-	1.0	W
Storage temperature (plastic)	$T_{stg}$	-65	+150	°C
Ambient temperature with $V_{CC}$ applied	$T_{bias}$	-55	+125	°C
DC current into outputs (low)	$I_{OUT}$	-	20	mA

Note: Stresses greater than those listed under *Absolute Maximum Ratings* may cause permanent damage to the device. This is a stress rating only and functional operation of the device at these or any other conditions outside those indicated in the operational sections of this specification is not implied. Exposure to absolute maximum rating conditions for extended periods may affect reliability.

## Truth table

CE1	CE2	$\overline{WE}$	$\overline{OE}$	Data	Mode
H	X	X	X	High Z	Standby ( $I_{SB}$ , $I_{SB1}$ )
X	L	X	X	High Z	Standby ( $I_{SB}$ , $I_{SB1}$ )
L	H	H	H	High Z	Output disable ( $I_{CC}$ )
L	H	H	L	$D_{OUT}$	Read ( $I_{CC}$ )
L	H	L	X	$D_{IN}$	Write ( $I_{CC}$ )

Key: X = don't care, L = low, H = high



### Recommended operating conditions

Parameter		Symbol	Min	Nominal	Max	Unit
Supply Voltage		$V_{CC}$	4.5	5.0	5.5	V
Input Voltage		$V_{IH}$	2.2	-	$V_{CC} + 0.5$	V
		$V_{IL}$	-0.5	-	0.8	V
Ambient operating temperature	commercial	$T_A$	0	-	70	°C
	industrial	$T_A$	-40	-	85	°C

$V_{IL}$  min = -1.0V for pulse width less than 5ns

$V_{IH}$  max =  $V_{CC} + 2.0V$  for pulse width less than 5ns.

### DC operating characteristics (over the operating range)<sup>1</sup>

Parameter	Sym	Test conditions	-10		-12		-15		-20		Unit
			Min	Max	Min	Max	Min	Max	Min	Max	
Input leakage current	$ I_{LI} $	$V_{CC} = \text{Max}, V_{IN} = \text{GND to } V_{CC}$	-	1	-	1	-	1	-	1	$\mu\text{A}$
Output leakage current	$ I_{LO} $	$V_{CC} = \text{Max}, \overline{\text{CE1}} = V_{IH}$ or $\text{CE2} = V_{IL}, V_{OUT} = \text{GND to } V_{CC}$	-	1	-	1	-	1	-	1	$\mu\text{A}$
Operating power supply current	$I_{CC}$	$V_{CC} = \text{Max}, \text{CE1} \leq V_{IL}, \text{CE2} \geq V_{IH}, f = f_{\text{Max}}, I_{\text{OUT}} = 0 \text{ mA}$	-	110	-	100	-	90	-	80	mA
Standby power supply current	$I_{SB}$	$V_{CC} = \text{Max}, \text{CE1} \geq V_{IH}$ and/or $\text{CE2} \leq V_{IL}, f = f_{\text{Max}}$	-	50	-	45	-	45	-	40	mA
	$I_{SB1}$	$V_{CC} = \text{Max}, \text{CE1} \geq V_{CC} - 0.2V$ and/or $\text{CE2} \leq 0.2V$ $V_{IN} \leq 0.2V$ or $V_{IN} \geq V_{CC} - 0.2V, f = 0$	-	10	-	10	-	10	-	10	
Output voltage	$V_{OL}$	$I_{OL} = 8 \text{ mA}, V_{CC} = \text{Min}$	-	0.4	-	0.4	-	0.4	-	0.4	V
	$V_{OH}$	$I_{OH} = -4 \text{ mA}, V_{CC} = \text{Min}$	2.4	-	2.4	-	2.4	-	2.4	-	

### Capacitance ( $f = 1 \text{ MHz}, T_a = 25 \text{ }^\circ\text{C}, V_{CC} = \text{NOMINAL}$ )<sup>2</sup>

Parameter	Symbol	Signals	Test conditions	Max	Unit
Input capacitance	$C_{IN}$	A, CE1, CE2, WE, OE	$V_{IN} = 0V$	5	pF
I/O capacitance	$C_{I/O}$	I/O	$V_{IN} = V_{OUT} = 0V$	7	pF



### Read cycle (over the operating range)<sup>3,9,12</sup>

Parameter	Symbol	-10		-12		-15		-20		Unit	Notes
		Min	Max	Min	Max	Min	Max	Min	Max		
Read cycle time	$t_{RC}$	10	-	12	-	15	-	20	-	ns	
Address access time	$t_{AA}$	-	10	-	12	-	15	-	20	ns	3
Chip enable ( $\overline{CE1}$ ) access time	$t_{ACE1}$	-	10	-	12	-	15	-	20	ns	3, 12
Chip enable ( $\overline{CE2}$ ) access time	$t_{ACE2}$	-	10	-	12	-	15	-	20	ns	3, 12
Output enable ( $\overline{OE}$ ) access time	$t_{OE}$	-	5	-	6	-	7	-	8	ns	
Output hold from address change	$t_{OH}$	3	-	3	-	3	-	3	-	ns	5
$\overline{CE1}$ Low to output in low Z	$t_{CLZ1}$	3	-	3	-	3	-	3	-	ns	4, 5, 12
$\overline{CE2}$ High to output in low Z	$t_{CLZ2}$	3	-	3	-	3	-	3	-	ns	4, 5, 12
$\overline{CE1}$ Low to output in high Z	$t_{CHZ1}$	-	4	-	5	-	6	-	7	ns	4, 5, 12
$\overline{CE2}$ Low to output in high Z	$t_{CHZ2}$	-	4	-	5	-	6	-	7	ns	4, 5, 12
$\overline{OE}$ Low to output in low Z	$t_{OLZ}$	0	-	0	-	0	-	0	-	ns	4, 5
$\overline{OE}$ High to output in high Z	$t_{OHZ}$	-	4	-	5	-	6	-	7	ns	4, 5
Power up time	$t_{PU}$	0	-	0	-	0	-	0	-	ns	4, 5, 12
Power down time	$t_{PD}$	-	10	-	12	-	15	-	20	ns	4, 5, 12

### Key to switching waveforms



### Read waveform 1 (address controlled)<sup>3,6,7,9,12</sup>

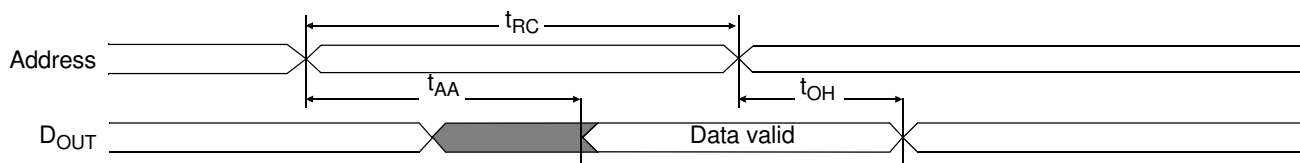

### Read waveform 2 ( $\overline{CE1}$ , $\overline{CE2}$ , and $\overline{OE}$ controlled)<sup>3,6,8,9,12</sup>

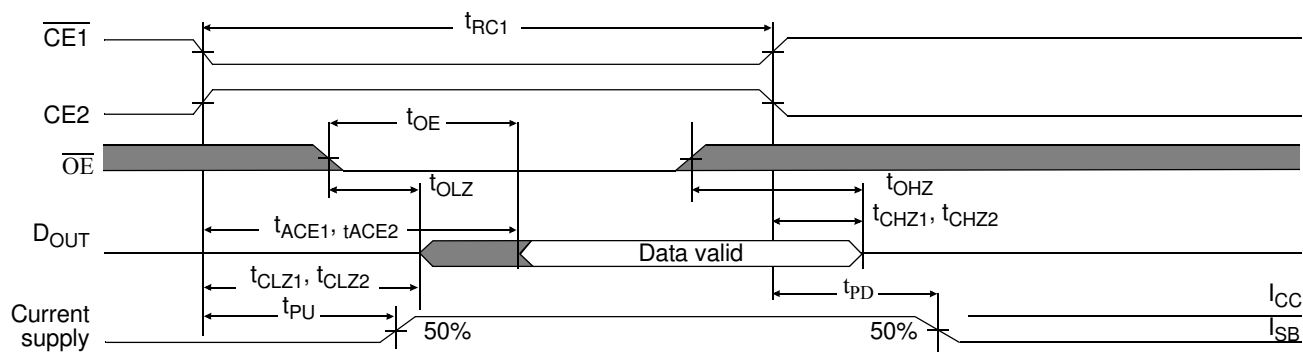



### Write cycle (over the operating range)<sup>11, 12</sup>

Parameter	Symbol	-10		-12		-15		-20		Unit	Notes
		Min	Max	Min	Max	Min	Max	Min	Max		
Write cycle time	$t_{WC}$	10	-	12	-	15	-	20	-	ns	
Chip enable (CE1) to write end	$t_{CW1}$	8	-	9	-	10	-	12	-	ns	12
Chip enable (CE2) to write end	$t_{CW2}$	8	-	9	-	10	-	12	-	ns	12
Address setup to write end	$t_{AW}$	8	-	9	-	10	-	12	-	ns	
Address setup time	$t_{AS}$	0		0	-	0	-	0	-	ns	12
Write pulse width	$t_{WP}$	7		8	-	9	-	12	-	ns	
Write recovery time	$t_{WR}$	0	-	0	-	0	-	0	-	ns	
Address hold from end of write	$t_{AH}$	0	-	0	-	0	-	0	-	ns	
Data valid to write end	$t_{DW}$	5		6	-	8	-	10	-	ns	
Data hold time	$t_{DH}$	0		0	-	0	-	0	-	ns	4, 5
Write enable to output in high Z	$t_{WZ}$	-	5	-	6	-	7	-	8	ns	4, 5
Output active from write end	$t_{OW}$	1	-	1	-	1	-	2	-	ns	4, 5

### Write waveform 1 ( $\overline{WE}$ controlled)<sup>10,11,12</sup>

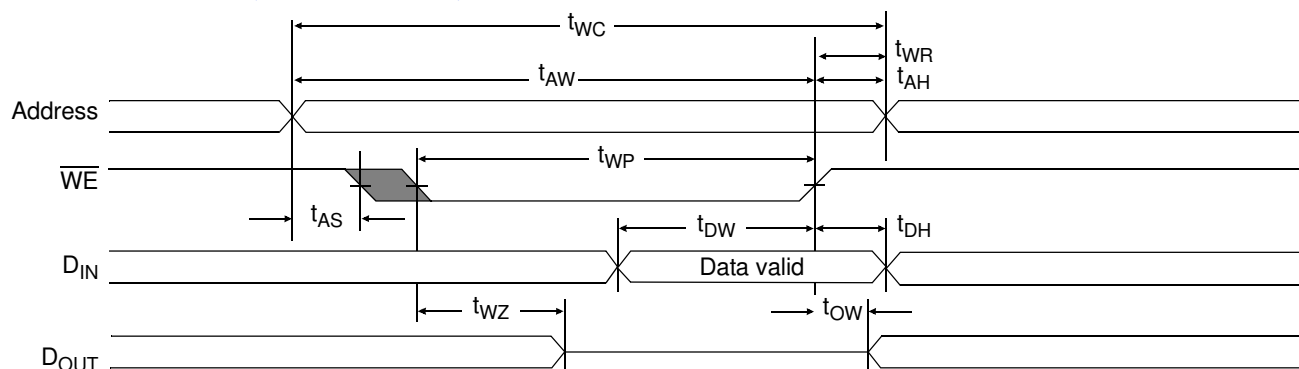



## Write waveform 2 ( $\overline{\text{CE1}}$ and $\text{CE2}$ controlled)<sup>10,11,12</sup>

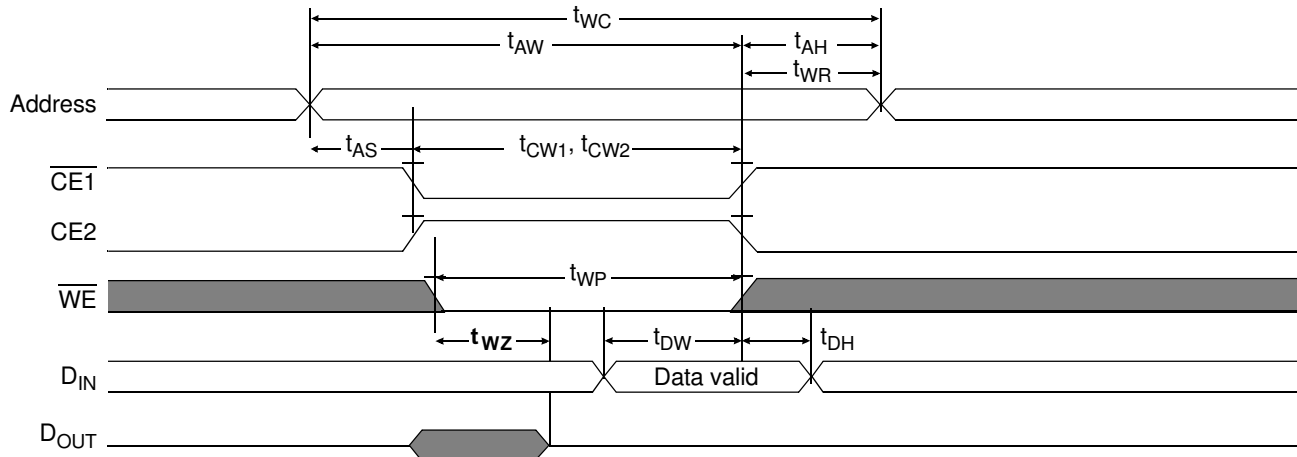

## AC test conditions

- Output load: see Figure B.
- Input pulse level: GND to 3.5V. See Figure A.
- Input rise and fall times: 2 ns. See Figure A.
- Input and output timing reference levels: 1.5V.

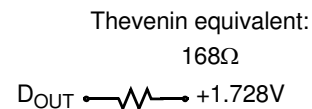
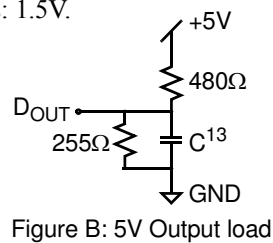
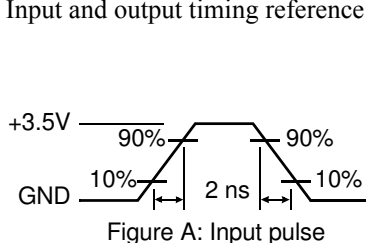

## Notes

- 1 During  $V_{CC}$  power-up, a pull-up resistor to  $V_{CC}$  on  $\overline{\text{CE1}}$  is required to meet  $I_{SB}$  specification.
- 2 This parameter is sampled and not 100% tested.
- 3 For test conditions, see *AC Test Conditions*, Figures A and B.
- 4  $t_{CLZ}$  and  $t_{CHZ}$  are specified with  $C_L = 5\text{pF}$ , as in Figure C. Transition is measured  $\pm 500\text{mV}$  from steady-state voltage.
- 5 This parameter is guaranteed, but not 100% tested.
- 6  $\overline{\text{WE}}$  is high for read cycle.
- 7  $\overline{\text{CE1}}$  and  $\overline{\text{OE}}$  are low and  $\text{CE2}$  is high for read cycle.
- 8 Address valid prior to or coincident with  $\overline{\text{CE1}}$  transition Low.
- 9 All read cycle timings are referenced from the last valid address to the first transitioning address.
- 10 N/A
- 11 All write cycle timings are referenced from the last valid address to the first transitioning address.
- 12  $\overline{\text{CE1}}$  and  $\text{CE2}$  have identical timing.
- 13  $C = 30\text{pF}$ , except all high Z and low Z parameters where  $C = 5\text{pF}$ .



Package dimensions

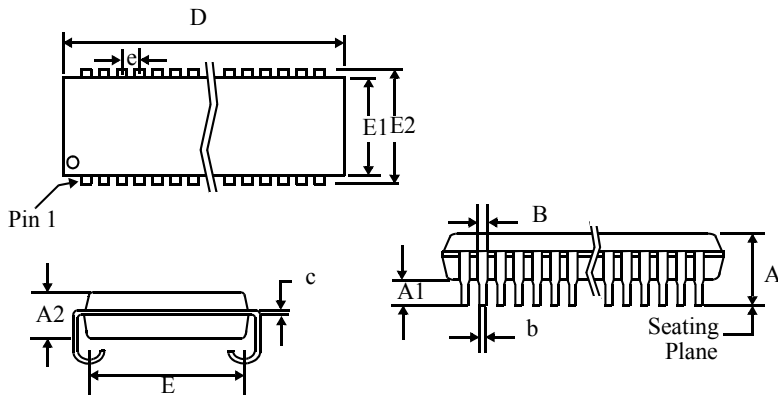

	32-pin SOJ 300 mil		32-pin SOJ 400 mil	
	Min	Max	Min	Max
A	0.128	0.145	0.132	0.146
A1	0.025	-	0.025	-
A2	0.095	0.105	0.105	0.115
B	0.026	0.032	0.026	0.032
b	0.016	0.020	0.015	0.020
c	0.007	0.010	0.007	0.013
D	0.820	0.830	0.820	0.830
E	0.255	0.275	0.354	0.378
E1	0.295	0.305	0.395	0.405
E2	0.330	0.340	0.435	0.445
e	0.050 BSC		0.050 BSC	

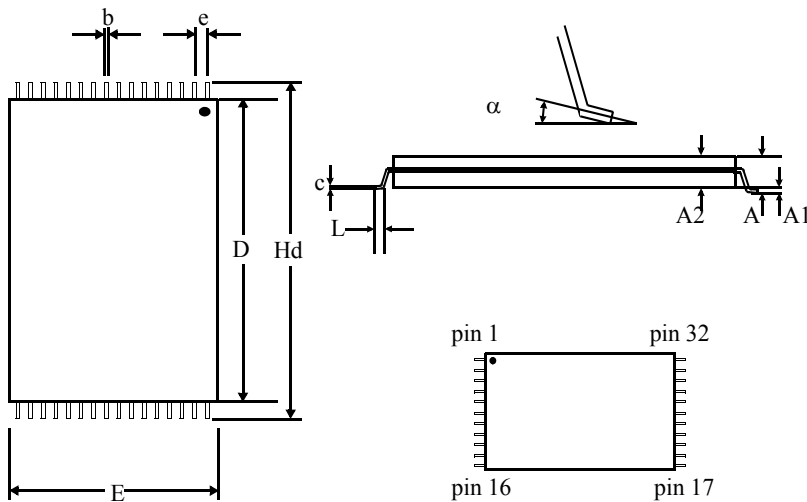

	32-pin TSOP 8x20 mm	
	Min	Max
A	-	1.20
A1	0.05	0.15
A2	0.95	1.05
b	0.17	0.27
c	0.10	0.21
D	18.30	18.50
e	0.50 nominal	
E	7.90	8.10
Hd	19.80	20.20
L	0.50	0.70
α	0°	5°



## Ordering codes

Package \ Access time	Temp	10 ns	12 ns	15 ns	20 ns
Plastic SOJ, 300 mil	commercial	AS7C1024B-10TJC	AS7C1024B-12TJC	AS7C1024B-15TJC	AS7C1024B-20TJC
	industrial	–	AS7C1024B-12TJI	AS7C1024B-15TJI	AS7C1024B-20TJI
Plastic SOJ, 400 mil	commercial	AS7C1024B-10JC	AS7C1024B-12JC	AS7C1024B-15JC	AS7C1024B-20JC
	industrial	–	AS7C1024B-12JI	AS7C1024B-15JI	AS7C1024B-20JI
TSOP1 8×20 mm	commercial	AS7C1024B-10TC	AS7C1024B-12TC	AS7C1024B-15TC	AS7C1024B-20TC
	-				
sTSOP1 8 x 13.4mm	commercial	AS7C1024B-10STC	AS7C1024B-12STC	AS7C1024B-15STC	AS7C1024B-20STC
	industrial	–	AS7C1024B-12STI	AS7C1024B-15STI	AS7C1024B-20STI

Note: Add suffix 'N' to the above part number for LEAD FREE PARTS (Ex: AS7C1024B-10TCN)

## Part numbering system

AS7C	1024B	-XX	X	X	X
SRAM prefix	Device number	Access time	Package: T = TSOP1 8×20 mm ST = sTSOP1 8 x 13.4 mm J = SOJ 400 mil TJ = SOJ 300 mil	Temperature range C = Commercial, 0° C to 70° C I = Industrial, -40° C to 85° C	N = LEAD FREE PART



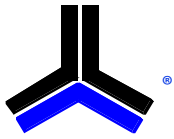

Alliance Memory, Inc.  
511 Taylor Way,  
San Carlos, CA 94070  
Tel: 650-610-6800  
Fax: 650-620-9211  
[www.alliancememory.com](http://www.alliancememory.com)

Copyright © Alliance Memory  
All Rights Reserved  
Part Number: AS7C1024B  
Document Version: v. 1.2

© Copyright 2003 Alliance Memory, Inc. All rights reserved. Our three-point logo, our name and Intelliwatt are trademarks or registered trademarks of Alliance. All other brand and product names may be the trademarks of their respective companies. Alliance reserves the right to make changes to this document and its products at any time without notice. Alliance assumes no responsibility for any errors that may appear in this document. The data contained herein represents Alliance's best data and/or estimates at the time of issuance. Alliance reserves the right to change or correct this data at any time, without notice. If the product described herein is under development, significant changes to these specifications are possible. The information in this product data sheet is intended to be general descriptive information for potential customers and users, and is not intended to operate as, or provide, any guarantee or warranty to any user or customer. Alliance does not assume any responsibility or liability arising out of the application or use of any product described herein, and disclaims any express or implied warranties related to the sale and/or use of Alliance products including liability or warranties related to fitness for a particular purpose, merchantability, or infringement of any intellectual property rights, except as express agreed to in Alliance's Terms and Conditions of Sale (which are available from Alliance). All sales of Alliance products are made exclusively according to Alliance's Terms and Conditions of Sale. The purchase of products from Alliance does not convey a license under any patent rights, copyrights; mask works rights, trademarks, or any other intellectual property rights of Alliance or third parties. Alliance does not authorize its products for use as critical components in life-supporting systems where a malfunction or failure may reasonably be expected to result in significant injury to the user, and the inclusion of Alliance products in such life-supporting systems implies that the manufacturer assumes all risk of such use and agrees to indemnify Alliance against all claims arising from such use.