



ON Semiconductor®

<http://onsemi.com>

LA6571

Monolithic Linear IC 5CH Driver for Mini Disk and Compact Disk

Overview

The LA6571 is 5-channel driver for mini disk and compact disk applications (BTL-AMP: 5CH).

Features

- Power amplifier 5-channel built-in.
- I_O max 1A
- Level shift circuit built-in.
- Mute circuit (output ON/OFF) with three built-in channels (2-2-1).
(Operates independently for each of MUTE1: CH1 and 2, MUTE2: CH3 and 4, and MUTE3: CH5.
Not operating for the regulator (REG))
- Regulator (REG) built-in (external PNP transistor).
Voltage setting (typ: 1.5V or more) with an external resistor
- Overheat protection circuit (thermal shutdown) built-in.

Specifications

Maximum Ratings at $T_a = 25^\circ\text{C}$

Parameter	Symbol	Conditions	Ratings	Unit
Supply voltage	V_{CC} max		14	V
Maximum output current	I_O max	Each output for channel 1 to 5.	1	A
Maximum input voltage	V_{INB}		13	V
MUTE pin voltage	V_{MUTE}		13	V
Allowable loss	P_d max	Independent IC	0.8	W
		Mounted on a specified board*	2	W
Operating temperature	T_{opr}		-30 to +85	$^\circ\text{C}$
Storage temperature	T_{stg}		-55 to +150	$^\circ\text{C}$

* Mounted on a specified board: 76.1mm×114.3mm×1.6mm glass epoxy

Stresses exceeding Maximum Ratings may damage the device. Maximum Ratings are stress ratings only. Functional operation above the Recommended Operating Conditions is not implied. Extended exposure to stresses above the Recommended Operating Conditions may affect device reliability.

Recommended Operating Conditions at $T_a = 25^\circ\text{C}$

Parameter	Symbol	Conditions	Ratings	Unit
Supply voltage 1	V_{CC1}		4.5 to V_{CC2}	V
Supply voltage 2	V_{CC2}		6 to 13	V

LA6571

Electrical Characteristics at $T_a = 25^\circ\text{C}$, $V_{CC1} = 5\text{V}$, $V_{CC2} = 12\text{V}$, $V_{REF-IN} = 1.65\text{V}$, unless especially specified

Parameter	Symbol	Conditions	Ratings			Unit
			min	typ	max	
[ALL Blocks]						
No-load current drain ON	$I_{CC\ ON}$	All outputs ON *1		30	50	mA
No-load current drain OFF	$I_{CC\ OFF}$	All outputs OFF *1		10	20	mA
VREF input voltage range	V_{REF-IN}		1		$V_{CC2}-1$	V
Thermal shutdown temperature	TSD	*7	150	175	200	$^\circ\text{C}$
[BTL AMP Block] (CH1 to CH5)						
Output offset voltage	V_{OFF}	Voltage difference in output between BTL AMP and each channel.	-50		50	mV
Output offset voltage	V_{OFF1}	Voltage difference in output between BTL AMP and each channel.	-80		80	mV
Output voltage	V_O	CH1,CH2 *3	3.2	4.0		V
Output voltage	V_{O1}	CH3,CH4,CH5 *4	9.7	10.5		V
Closed-circuit voltage gain	V_G1	Gain between input and output for CH1, CH2, and CH5 *2	4.2	5.0	6.0	times
Closed-circuit voltage gain	V_G3	Gain between input and output for CH3 and CH4 *2	8.2	9.0	11.0	times
Slew rate	SR	AMP independent. Multiply 2 between outputs. *7		0.5		$\text{V}/\mu\text{s}$
MUTE ON voltage	$V_{MUTE\ ON}$	Each MUTE *6	2			V
MUTE OFF voltage	$V_{MUTE\ OFF}$	Each MUTE *6			0.5	V
[Input AMP Block]						
Input voltage range	$V_{IN\ op}$		0		$V_{CC2}-1.5$	V
Output offset voltage	$V_{OFF\ op}$		-10		10	mV
Output current (SINK)	SINK op		2			mA
Output current (SOURCE)	SOURCE op	*5	300	500		μA
[Power Supply Block] (PNP transistor: 2SB632K)						
Regulator output	V_{OUT}	For error Amp, $R_L = 10\text{k}\Omega$ at buffer	1.2	1.3	1.4	V
REG-IN SINK current	REG-IN-SINK	Base current to external PNP	5	10		mA
Line regulation	ΔV_{OLN}	$6\text{V} \leq V_{CC} \leq 12\text{V}$, $I_O = 200\text{mA}$		20	150	mV
Load regulation	ΔV_{OLD}	$5\text{mA} \leq I_O \leq 200\text{mA}$		50	200	mV

*1. Current dissipation that is a sum of V_{CC1} and V_{CC2} at no load.

*2. Input AMP is a BUFFER AMP.

*3. Voltage difference between both ends of load (8Ω). Output saturated.

*4. Voltage difference between both ends of load (12Ω). Output saturated.

*5. The source of input OP-AMP is a constant current. (See the specified block diagram.)

As the $11\text{k}\Omega$ resistance to the next stage is a load, pay due attention when setting the input OP-AMP gain.

*6. Output ON with MUTE: [H] and OFF with MUTE: [L] (HI impedance).

*7. Design guarantee value

Package Dimensions

unit : mm
3251

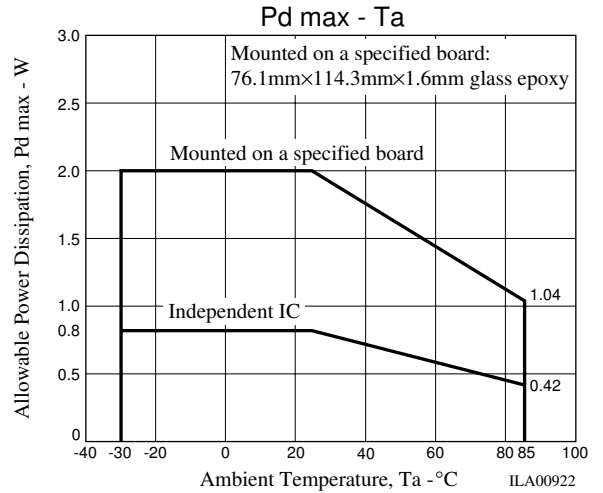
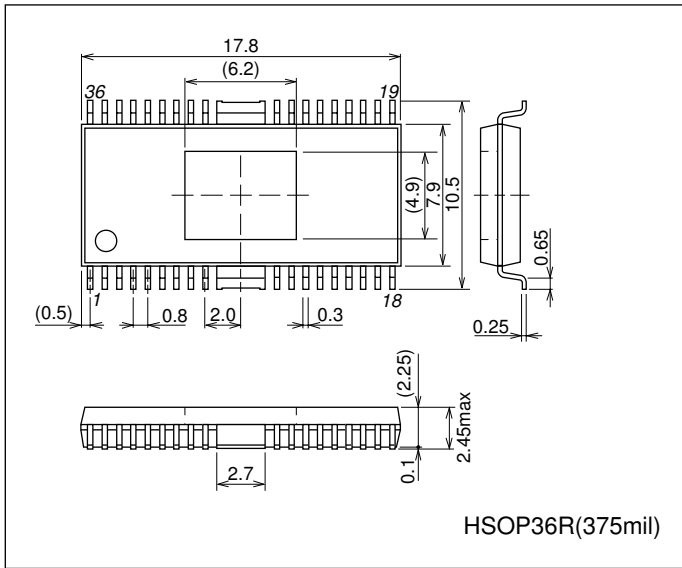

Pin Description

Pin Name	Pin Name	Pin No.	Equivalent Circuit Diagram	Description
Input	V _{IN1+} V _{IN1-} V _{IN1} V _{IN2+} V _{IN2-} V _{IN2} V _{IN3+} V _{IN3-} V _{IN3} V _{IN4+} V _{IN4-} V _{IN4} V _{IN5+} V _{IN5-} V _{IN5}	17 16 15 20 19 18 23 22 21 30 31 32 33 34		Each input pin
Output	V _{O1+} V _{O1-} V _{O2+} V _{O2-} V _{O3+} V _{O3-} V _{O4+} V _{O4-} V _{O5+} V _{O5-}	12 13 10 11 8 9 6 7 5 4		Each output
MUTE	MUTE1 MUTE2 MUTE3	1 2 36		Turns ON/OFF the output for MUTE1: CH1, 2 MUTE2: CH3, 4, and MUTE3: CH5. Each MUTE operates independently. MUTE: H output ON MUTE: L output OFF With the output OFF, the output has a high impedance.

Relationship between MUTE and Power (VCC)

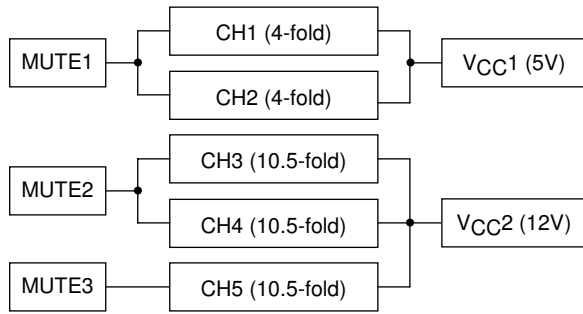

* MUTE operates independently for each corresponding channel.

Schematic Diagram of I/O Related Components

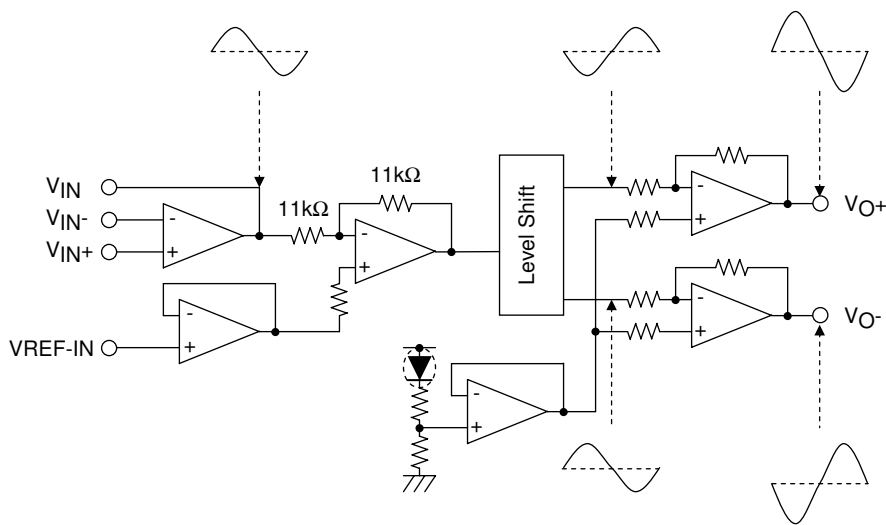

Block Diagram

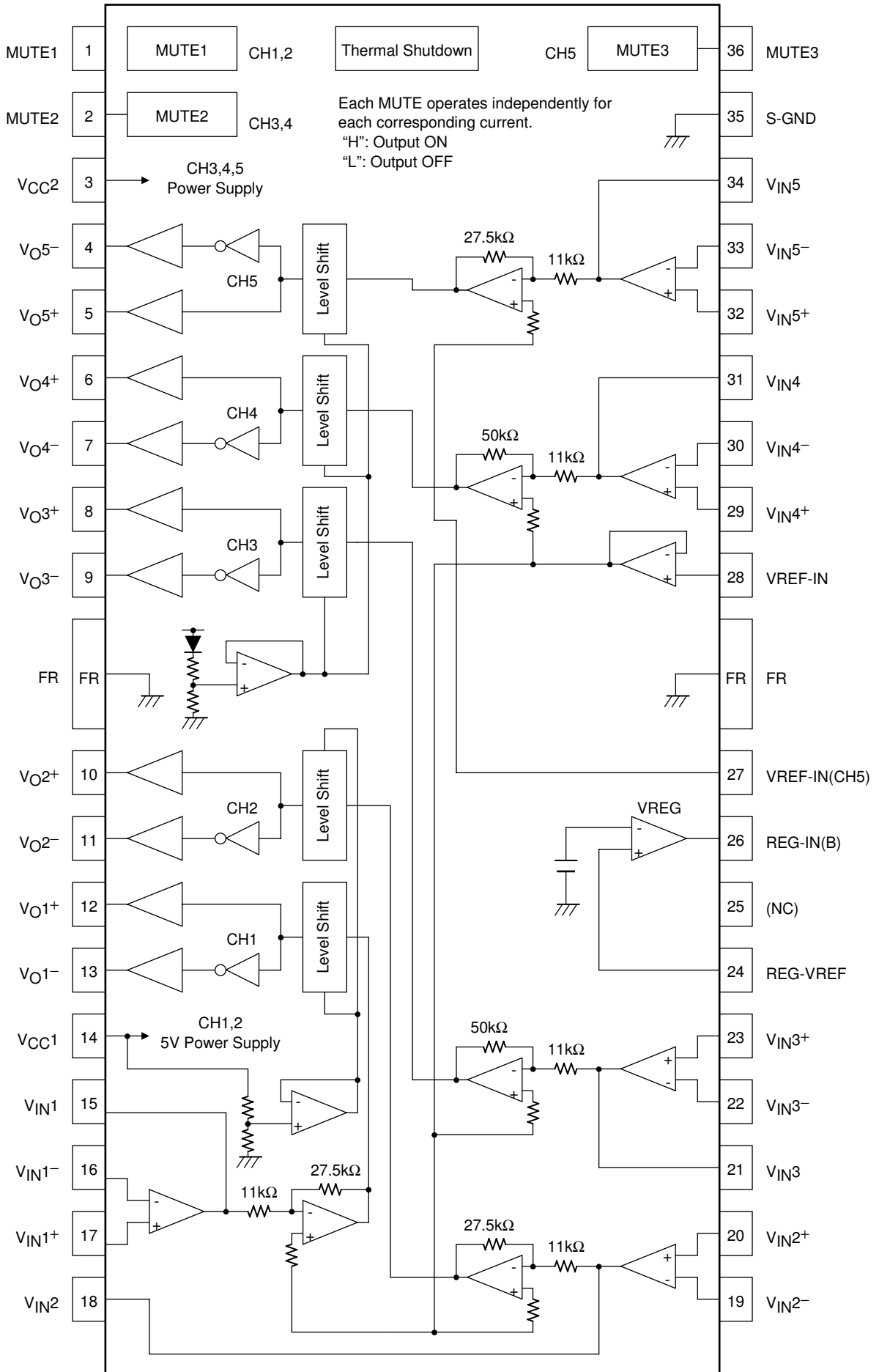

Sample Application Circuit

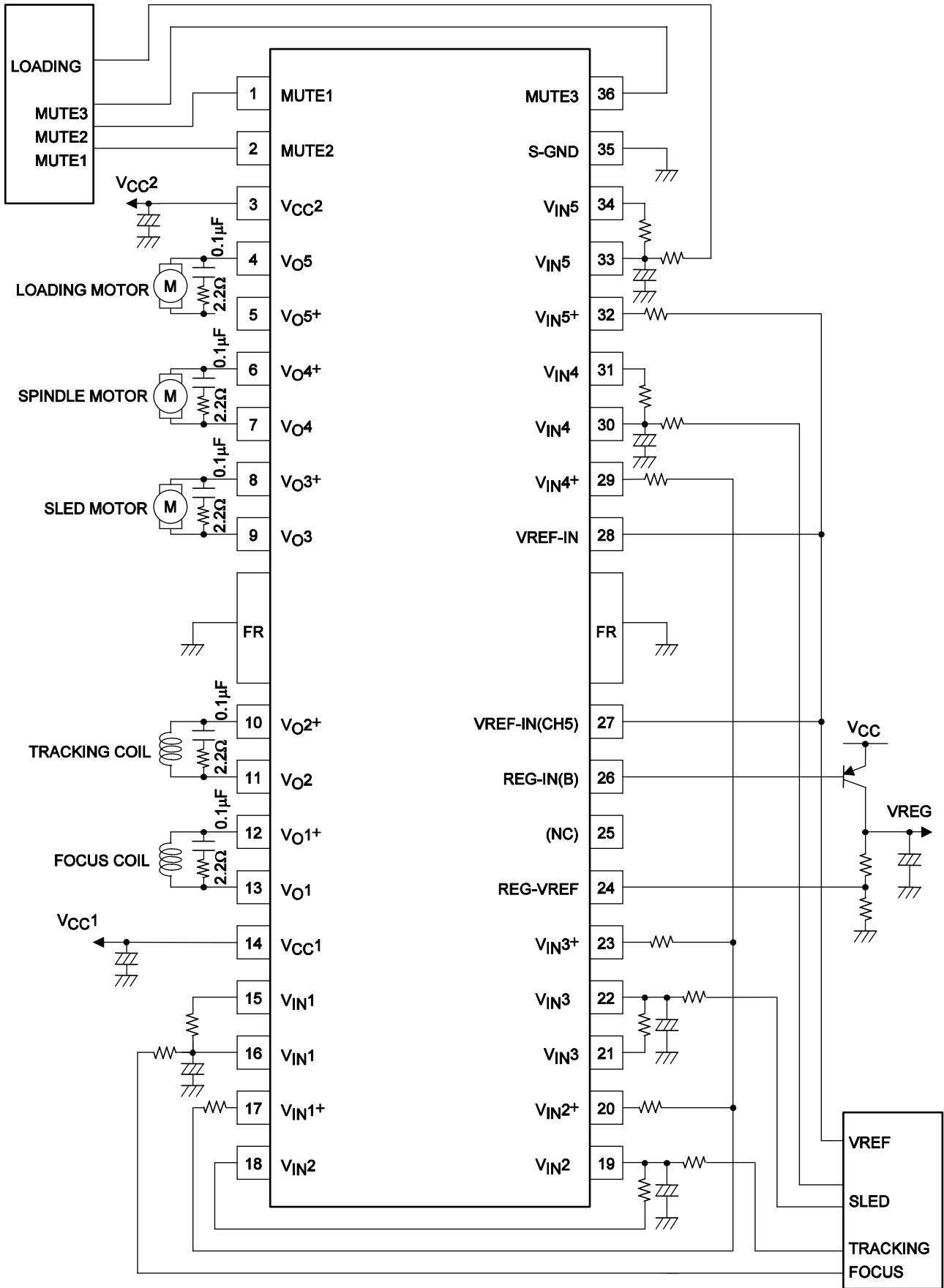

ON Semiconductor and the ON logo are registered trademarks of Semiconductor Components Industries, LLC (SCILLC). SCILLC owns the rights to a number of patents, trademarks, copyrights, trade secrets, and other intellectual property. A listing of SCILLC's product/patent coverage may be accessed at www.onsemi.com/site/pdf/Patent-Marking.pdf. SCILLC reserves the right to make changes without further notice to any products herein. SCILLC makes no warranty, representation or guarantee regarding the suitability of its products for any particular purpose, nor does SCILLC assume any liability arising out of the application or use of any product or circuit, and specifically disclaims any and all liability, including without limitation special, consequential or incidental damages. "Typical" parameters which may be provided in SCILLC data sheets and/or specifications can and do vary in different applications and actual performance may vary over time. All operating parameters, including "Typicals" must be validated for each customer application by customer's technical experts. SCILLC does not convey any license under its patent rights nor the rights of others. SCILLC products are not designed, intended, or authorized for use as components in systems intended for surgical implant into the body, or other applications intended to support or sustain life, or for any other application in which the failure of the SCILLC product could create a situation where personal injury or death may occur. Should Buyer purchase or use SCILLC products for any such unintended or unauthorized application, Buyer shall indemnify and hold SCILLC and its officers, employees, subsidiaries, affiliates, and distributors harmless against all claims, costs, damages, and expenses, and reasonable attorney fees arising out of, directly or indirectly, any claim of personal injury or death associated with such unintended or unauthorized use, even if such claim alleges that SCILLC was negligent regarding the design or manufacture of the part. SCILLC is an Equal Opportunity/Affirmative Action Employer. This literature is subject to all applicable copyright laws and is not for resale in any manner.