



ON Semiconductor®

<http://onsemi.com>

LB1847

Monolithic Digital IC PWM Current Control Type Stepping Motor Driver

Overview

The LB1847 is a driver IC for stepping motors with PWM current control bipolar drive (fixed OFF time). A special feature of this IC is that VREF voltage is constant while the current can be set in 15 steps, allowing drive of motors ranging from 1-2 phase exciter types to 4W 1-2 phase exciter types. The current decay pattern can also be selected (SLOW DECAY, FAST DECAY, MIX DECAY) to increase the decay of regenerative current at chopping OFF, thereby improving response characteristics. This is especially useful for carriage and paper feed stepping motors in printers and similar applications where high-precision control and low vibrations are required.

Features

- PWM current control (fixed OFF time)
- Load current digital selector (1-2, W1-2, 2W1-2, 4W1-2 phase exciter drive possible)
- Selectable current decay pattern (SLOW DECAY, FAST DECAY, MIX DECAY)
- Simultaneous ON prevention function (feed-through current prevention)
- Noise canceler
- Built-in thermal shutdown circuit
- Built-in logic low-voltage OFF circuit

Specifications

Absolute Maximum Ratings at Ta = 25°C

Parameter	Symbol	Conditions	Ratings	Unit
Motor supply voltage	V _{BB}		50	V
Output peak current	I _{O peak}	t _W = 20μs	1.75	A
Output continuous current	I _{O max}		1.5	A
Logic supply voltage	V _{CC}		7.0	A
Logic input voltage range	V _{IN}		-0.3 to V _{CC}	V
Emitter output voltage	V _E		1.0	V
Allowable power dissipation	Pd max	Independent IC	3.0	W
		With infinitely large heat sink	20	W
Operating temperature	Topr		-20 to +85	°C
Storage temperature	Tstg		-55 to +150	°C

Stresses exceeding Maximum Ratings may damage the device. Maximum Ratings are stress ratings only. Functional operation above the Recommended Operating Conditions is not implied. Extended exposure to stresses above the Recommended Operating Conditions may affect device reliability.

LB1847

Allowable Operating Ranges at Ta = 25°C

Parameter	Symbol	Conditions	Ratings	Unit
Motor supply voltage range	V _{BB}		10 to 45	V
Logic supply voltage	V _{CC}		4.75 to 5.25	V
Reference voltage range	V _{REF}		0.0 to 3.0	V

Electrical Characteristics at Ta = 25°C, V_{BB} = 45V, V_{CC} = 5V, V_{REF} = 1.52V

Parameter	Symbol	Conditions	Ratings			Unit
			min	typ	max	
Output Block						
Output stage supply voltage	I _{BB ON}		2.3	3.5	5.0	mA
	I _{BB OFF}		0.5	0.8	1.1	mA
Output saturation voltage	V _{O(sat)1}	I _O = +1.0A, sink		1.2	1.6	V
	V _{O(sat)2}	I _O = +1.5A, sink		1.5	1.9	V
	V _{O(sat)3}	I _O = -1.0A, source		1.9	2.2	V
	V _{O(sat)4}	I _O = -1.5A, source		2.2	2.4	V
Output leak current	I _{O(leak)1}	V _O = V _{BB} , sink			50	μA
	I _{O(leak)2}	V _O = 0V, source	-50			μA
Output sustain voltage	V _{SUS}	L = 15mH, I _O = 1.5A, Guaranteed design value *	45			V
Logic Block						
Logic supply voltage	I _{CC ON}	I ₄ = 3.2V, I ₃ = 3.2V, I ₂ = 3.2V, I ₁ = 3.2V	19.5	26	36.5	mA
	I _{CC OFF}	ENABLE = 3.2V	10.5	15	19.5	mA
Input voltage	V _{IH}		3.2			V
	V _{IL}				0.8	V
Input current	I _{IH}	V _{IH} = 3.2V			100	μA
	I _{IL}	V _{IL} = 0.8V	-10			μA
Sensing voltage	V _E	I ₄ = 3.2V, I ₃ = 3.2V, I ₂ = 3.2V, I ₁ = 3.2V	0.470	0.50	0.525	V
		I ₄ = 3.2V, I ₃ = 3.2V, I ₂ = 3.2V, I ₁ = 0.8V	0.445	0.48	0.505	V
		I ₄ = 3.2V, I ₃ = 3.2V, I ₂ = 0.8V, I ₁ = 3.2V	0.425	0.46	0.485	V
		I ₄ = 3.2V, I ₃ = 3.2V, I ₂ = 0.8V, I ₁ = 0.8V	0.410	0.43	0.465	V
		I ₄ = 3.2V, I ₃ = 0.8V, I ₂ = 3.2V, I ₁ = 3.2V	0.385	0.41	0.435	V
		I ₄ = 3.2V, I ₃ = 0.8V, I ₂ = 3.2V, I ₁ = 0.8V	0.365	0.39	0.415	V
		I ₄ = 3.2V, I ₃ = 0.8V, I ₂ = 0.8V, I ₁ = 3.2V	0.345	0.37	0.385	V
		I ₄ = 3.2V, I ₃ = 0.8V, I ₂ = 0.8V, I ₁ = 0.8V	0.325	0.35	0.365	V
		I ₄ = 0.8V, I ₃ = 3.2V, I ₂ = 3.2V, I ₁ = 3.2V	0.280	0.30	0.325	V
		I ₄ = 0.8V, I ₃ = 3.2V, I ₂ = 3.2V, I ₁ = 0.8V	0.240	0.26	0.285	V
		I ₄ = 0.8V, I ₃ = 3.2V, I ₂ = 0.8V, I ₁ = 3.2V	0.195	0.22	0.235	V
		I ₄ = 0.8V, I ₃ = 3.2V, I ₂ = 0.8V, I ₁ = 0.8V	0.155	0.17	0.190	V
		I ₄ = 0.8V, I ₃ = 0.8V, I ₂ = 3.2V, I ₁ = 3.2V	0.115	0.13	0.145	V
		I ₄ = 0.8V, I ₃ = 0.8V, I ₂ = 3.2V, I ₁ = 0.8V	0.075	0.09	0.100	V
Reference current	I _{REF}	V _{REF} = 1.5V	-0.5			μA
CR pin current	I _{CR}	CR = 1.0V	-4.6		-1.0	mA
MD pin current	I _{MD}	MD = 1.0V, CR = 4.0V	-5.0			μA
DECAY pin current Low	I _{DECL}	V _{DEC} = 0.8V	-10			μA
DECAY pin current High	I _{DECH}	V _{DEC} = 3.2V			5	μA
Thermal shutdown temperature	TSD			170		°C
Logic ON voltage	L _{VSD1}		3.35	3.65	3.95	V
Logic OFF voltage	L _{VSD2}		3.20	3.50	3.80	V
LVSD hysteresis width	ΔL _{VSD}		0.065	0.15	0.23	V

LB1847

Package Dimensions

unit : mm (typ)
3147C

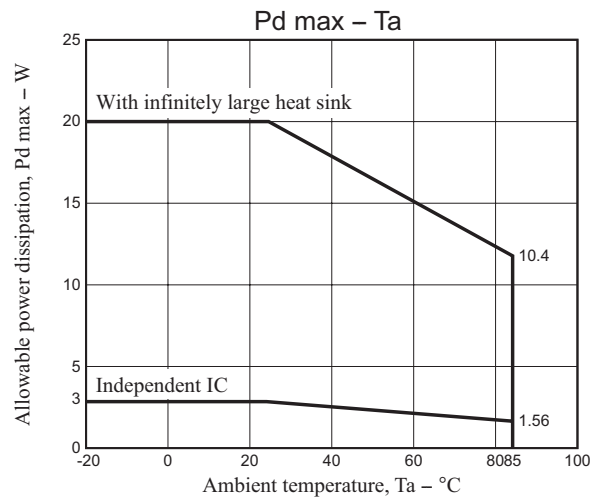
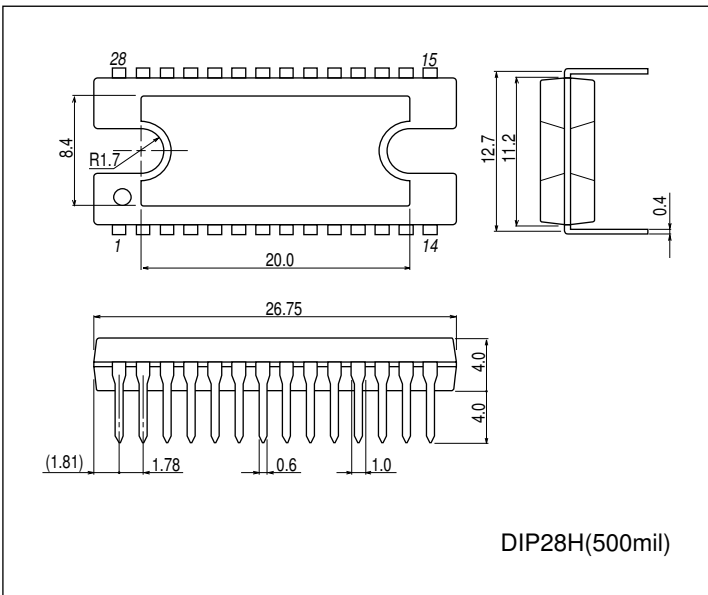

Pin Assignment

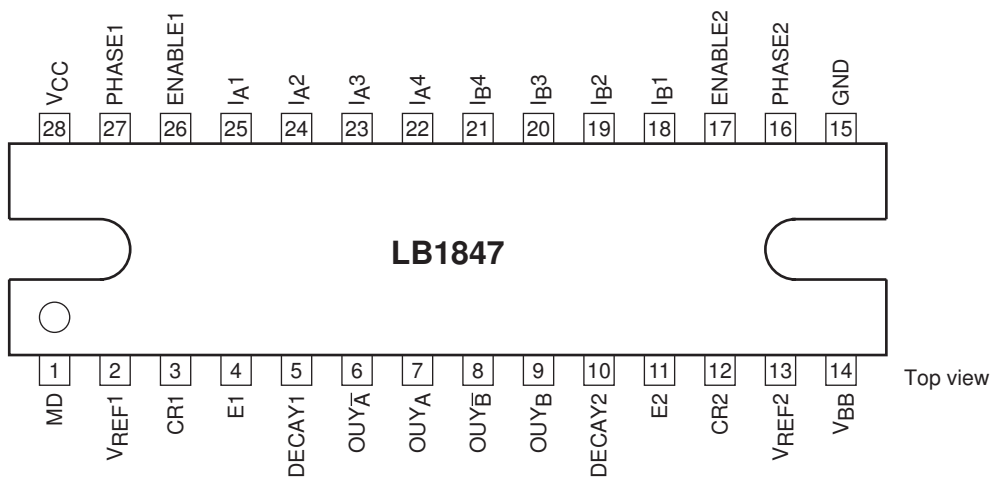

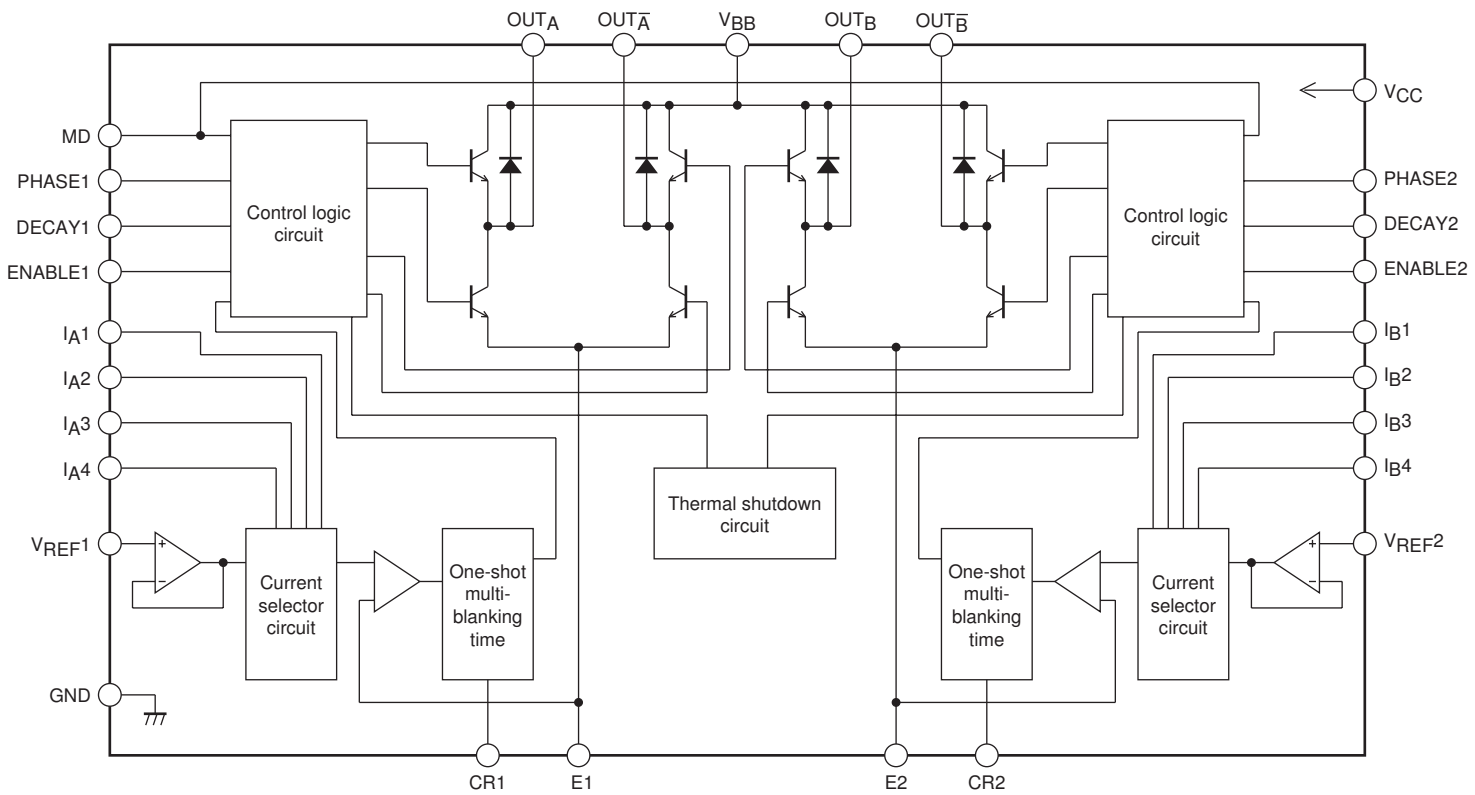

LB1847

Pin Function

Pin No.	Pin name	Function
1	MD	Sets the OFF time for FAST mode and SLOW mode in MIX DECAY. Setting input range: 4V to 1.5V.
2 13	V _{REF1} V _{REF2}	Output set current reference supply pin. Setting voltage range: 0V to 3V.
3 12	CR1 CR2	Output OFF time setting pin for switching operation.
4 11	E1 E2	Pin for controlling the set current with sensing resistor RE.
5 10	DECAY1 DECAY2	SLOW mode/FAST mode selector pin. DECAY2 SLOW DECAY: H FAST DECAY: L
6 7 8 9	OUT _A OUT _A OUT _B OUT _B	Output pin.
14	V _{BB}	Output stage supply voltage pin.
15	GND	Ground pin.
27 16	PHASE1 PHASE2	Output phase selector input pin
26 17	ENABLE1 ENABLE2	Output ON/OFF setting input pin.
22,23 24,25 21,20 19,18	I _{A4} , I _{A3} I _{A2} , I _{A1} I _{B4} , I _{B3} I _{B2} , I _{B1}	Output set current digital input pin. 15-stage voltage setting.
28	V _{CC}	Logic block supply voltage pin

Truth Table

PHASE	ENABLE	OUT _A	OUT _A
H	L	H	L
L	L	L	H
-	H	OFF	OFF

Set Current Truth Table

I _{A4}	I _{A3}	I _{A2}	I _{A1}	Set current I _{out}	Current ratio
1	1	1	1	$11.5/11.5 \times V_{REF}/3.04RE = I_{out}$	100
1	1	1	0	$11.0/11.5 \times V_{REF}/3.04RE = I_{out}$	95.65
1	1	0	1	$10.5/11.5 \times V_{REF}/3.04RE = I_{out}$	91.30
1	1	0	0	$10.0/11.5 \times V_{REF}/3.04RE = I_{out}$	86.95
1	0	1	1	$9.5/11.5 \times V_{REF}/3.04RE = I_{out}$	82.61
1	0	1	0	$9.0/11.5 \times V_{REF}/3.04RE = I_{out}$	78.26
1	0	0	1	$8.5/11.5 \times V_{REF}/3.04RE = I_{out}$	73.91
1	0	0	0	$8.0/11.5 \times V_{REF}/3.04RE = I_{out}$	69.56
0	1	1	1	$7.0/11.5 \times V_{REF}/3.04RE = I_{out}$	60.87
0	1	1	0	$6.0/11.5 \times V_{REF}/3.04RE = I_{out}$	52.17
0	1	0	1	$5.0/11.5 \times V_{REF}/3.04RE = I_{out}$	43.48
0	1	0	0	$4.0/11.5 \times V_{REF}/3.04RE = I_{out}$	34.78
0	0	1	1	$3.0/11.5 \times V_{REF}/3.04RE = I_{out}$	26.08
0	0	1	0	$2.0/11.5 \times V_{REF}/3.04RE = I_{out}$	17.39

* Current ratio (%) is the calculated set current value.

Current Decay Switching Truth Table

Current decay mode	DECAY pin	MD pin	Output chopping
SLOW DECAY	H	L	Upper-side chopping
FAST DECAY	L	L	Dual-side chopping
MIX DECAY	L	4V to 1.5V input voltage setting	CR voltage > MD: dual-side chopping CR voltage < MD: upper-side chopping

LB1847

Sequence Table

No.	Phase A							Phase B							Phase 1-2	Phase W1-2	Phase 2W1-2	Phase 4W1-2
	I _{A4}	I _{A3}	I _{A2}	I _{A1}	ENA1	PHA1	I _{out}	I _{B4}	I _{B3}	I _{B2}	I _{B1}	ENA2	PHA2	I _{out}				
0	1	1	1	1	0	0	100%	0	0	1	0	1	*	0%	○	○	○	○
1	1	1	1	1	0	0	100	0	0	1	0	0	0	17.39				○
2	1	1	1	1	0	0	100	0	0	1	1	0	0	26.08			○	○
3	1	1	1	0	0	0	95.65	0	1	0	0	0	0	34.78				○
4	1	1	0	1	0	0	91.30	0	1	0	1	0	0	43.48		○	○	○
5	1	1	0	0	0	0	86.95	0	1	1	0	0	0	52.17				○
6	1	0	1	1	0	0	82.61	0	1	1	1	0	0	60.87			○	○
7	1	0	1	0	0	0	78.26	1	0	0	0	0	0	69.56				○
8	1	0	0	1	0	0	73.91	1	0	0	1	0	0	73.91	○	○	○	○
9	1	0	0	0	0	0	69.56	1	0	1	0	0	0	78.26				○
10	0	1	1	1	0	0	60.87	1	0	1	1	0	0	82.61			○	○
11	0	1	1	0	0	0	52.17	1	1	0	0	0	0	86.95				○
12	0	1	0	1	0	0	43.48	1	1	0	1	0	0	91.30		○	○	○
13	0	1	0	0	0	0	34.78	1	1	1	0	0	0	95.65				○
14	0	0	1	1	0	0	26.08	1	1	1	1	0	0	100			○	○
15	0	0	1	0	0	0	17.39	1	1	1	1	0	0	100				○
16	0	0	0	1	1	*	0	1	1	1	1	0	0	100	○	○	○	○
17	0	0	1	0	0	1	17.39	1	1	1	1	0	0	100				○
18	0	0	1	1	0	1	26.08	1	1	1	1	0	0	100			○	○
19	0	1	0	0	0	1	34.78	1	1	1	0	0	0	95.65				○
20	0	1	0	1	0	1	43.48	1	1	0	1	0	0	91.30		○	○	○
21	0	1	1	0	0	1	52.17	1	1	0	0	0	0	86.95				○
22	0	1	1	1	0	1	60.87	1	0	1	1	0	0	82.61			○	○
23	1	0	0	0	0	1	69.56	1	0	1	0	0	0	78.26				○
24	1	0	0	1	0	1	73.91	1	0	0	1	0	0	73.91	○	○	○	○
25	1	0	1	0	0	1	78.26	1	0	0	0	0	0	69.56				○
26	1	0	1	1	0	1	82.61	0	1	1	1	0	0	60.87			○	○
27	1	1	0	0	0	1	86.95	0	1	1	0	0	0	52.17				○
28	1	1	0	1	0	1	91.30	0	1	0	1	0	0	43.48		○	○	○
29	1	1	1	0	0	1	95.65	0	1	0	0	0	0	34.78				○
30	1	1	1	1	0	1	100	0	0	1	1	0	0	26.08			○	○
31	1	1	1	1	0	1	100	0	0	1	0	0	0	17.39				○

* Don't care

Note: I_{out} percentage (%) is the calculated setting value.

Switch Timing Chart During PWM Drive

SLOW DECAY (upper-side chopping)

DECAY pin: High MD pin: Low

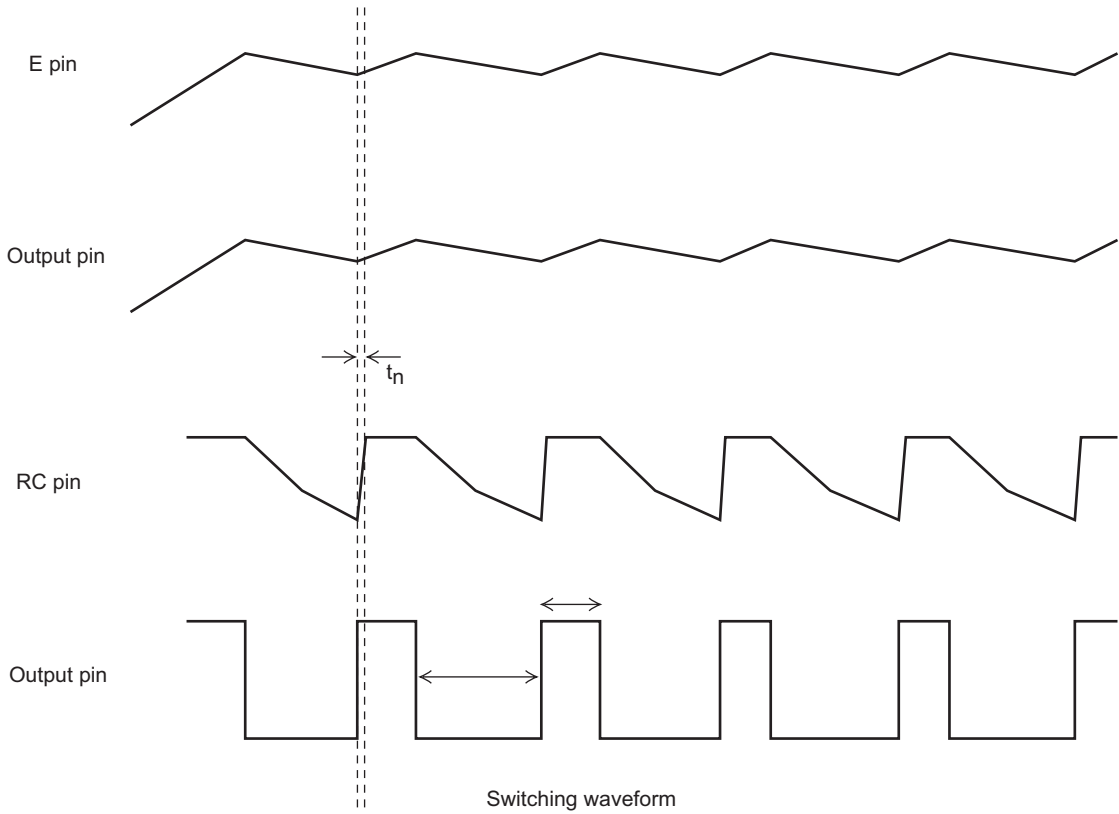

FAST DECAY

DECAY pin: Low MD pin: Low

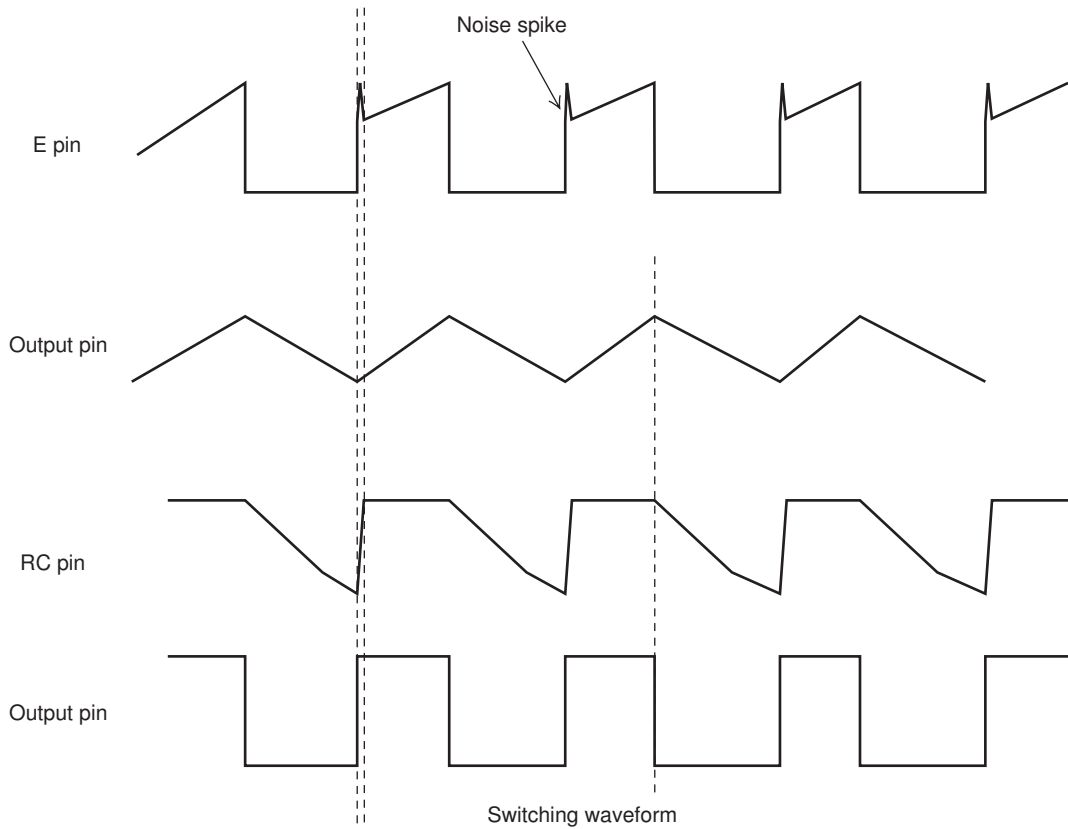

MIX DECAY

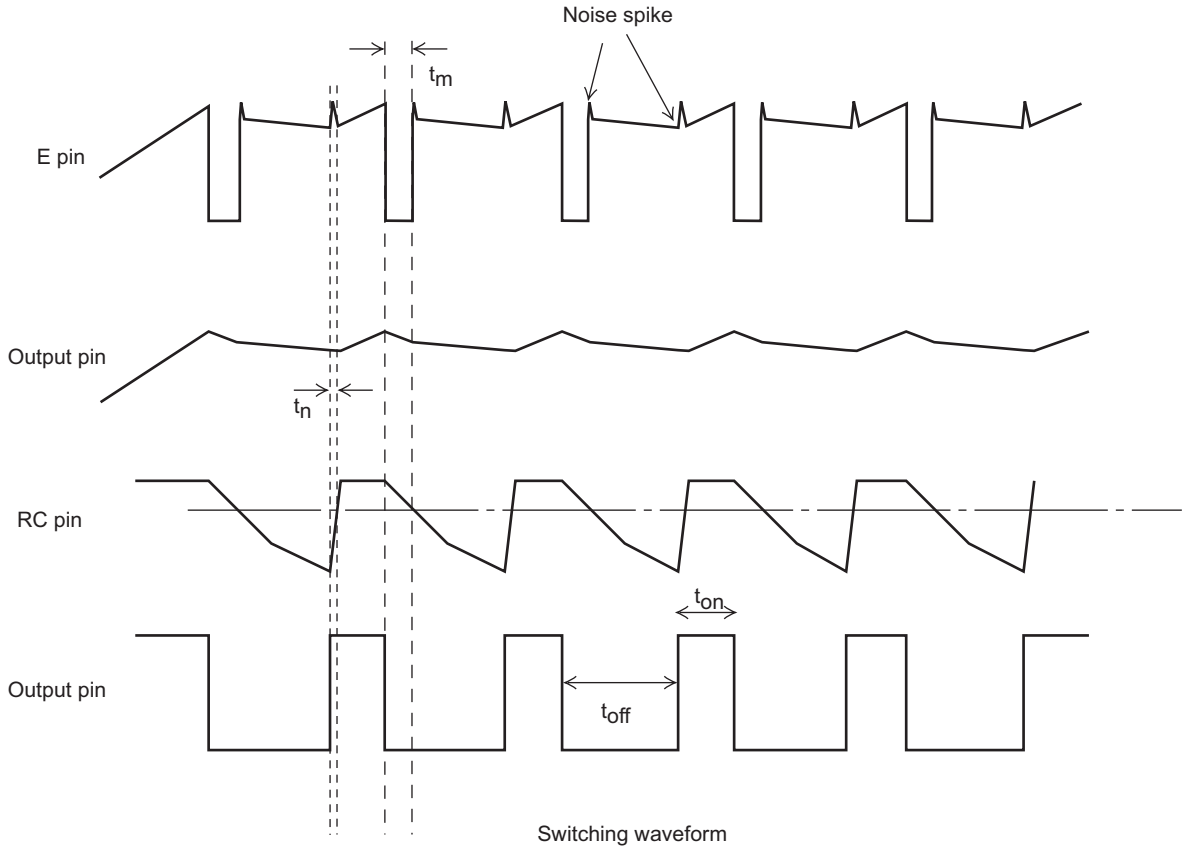

- t_{on} : Output ON time
- t_{off} : Output OFF time
- t_m : FAST DECAY time in MIX DECAY mode
- t_n : Noise cancelling time

MIX DECAY logic setting

DECAY pin : L

MD pin : 1.5V to 4.0V voltage setting

CR voltage and MD pin voltage are compared to select dual-side chopping or upper-side chopping.

CR voltage > MD pin voltage: dual-side chopping

CR voltage < MD pin voltage: upper-side chopping

SLOW DECAY Current Path

Regenerative current during upper-side transistor switching operation

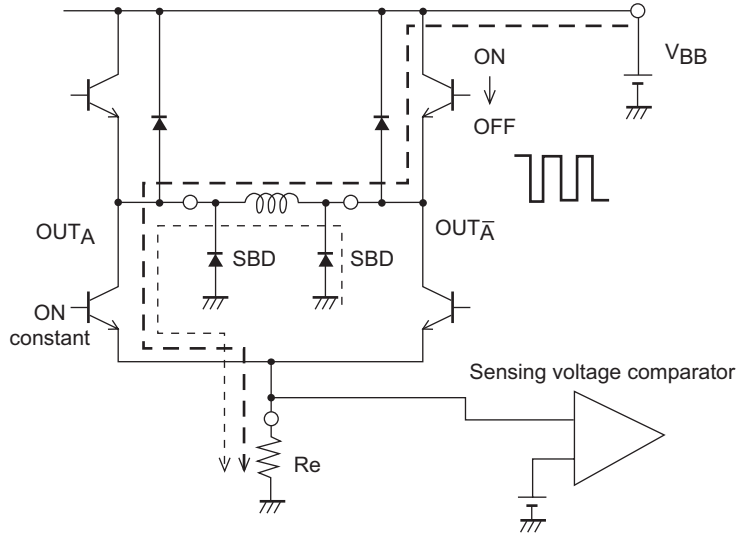
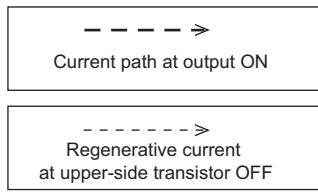

FAST DECAY Current Path

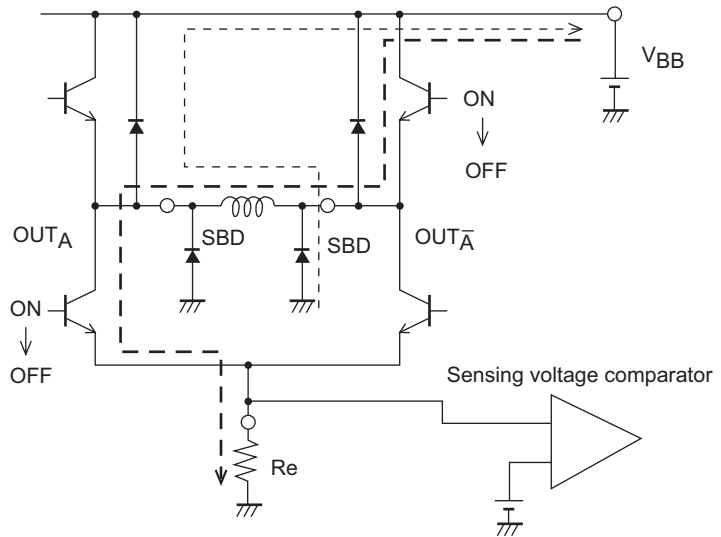
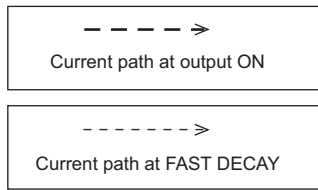

Composite Spectrum of Set Current (1 step normalized to 90°)

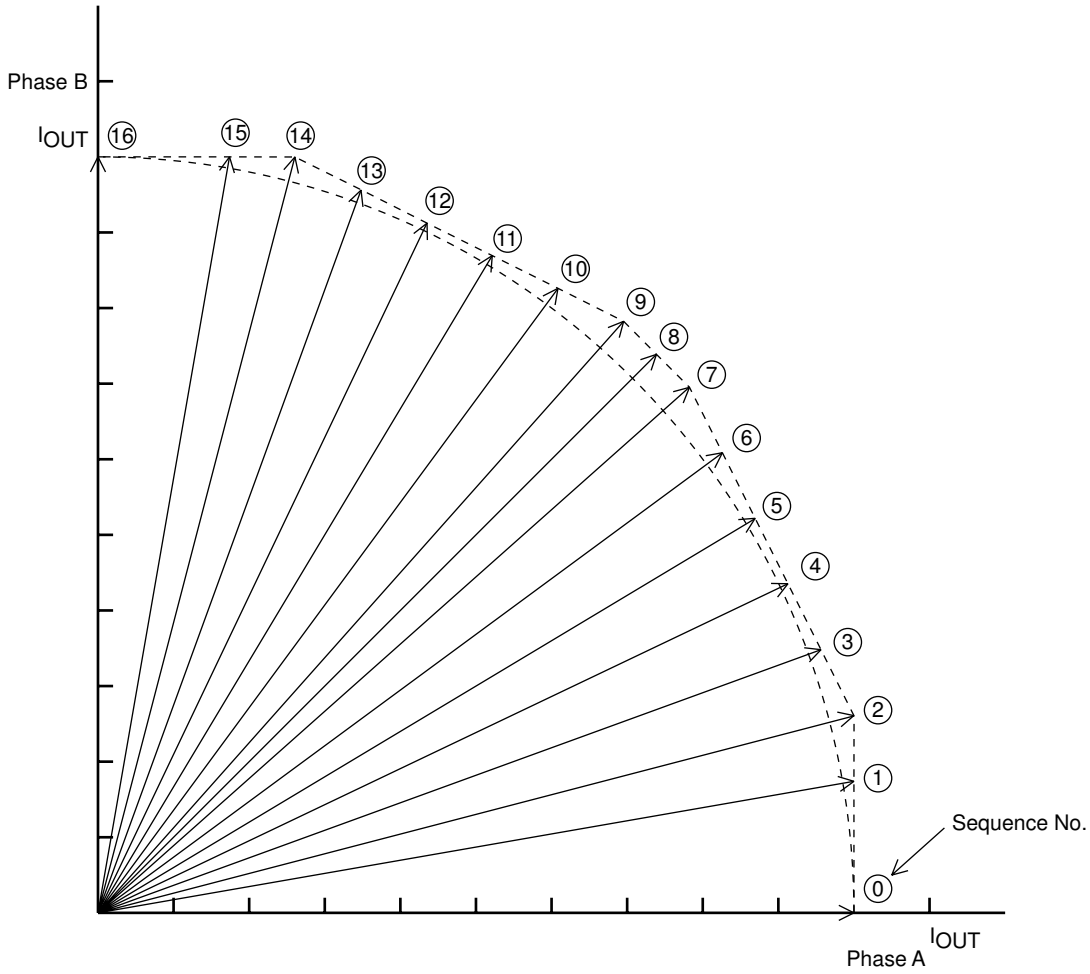

No.	θ	Rotation angle	Composite spectrum
0	θ_0	0°	100.0
1	θ_1	9.87°	101.5
2	θ_2	14.6°	103.35
3	θ_3	20.0°	101.78
4	θ_4	25.5°	101.12
5	θ_5	30.96°	101.4
6	θ_6	36.38°	102.61
7	θ_7	41.63°	104.7
8	θ_8	45.0°	104.5
9	θ_9	48.37°	104.7
10	θ_{10}	53.62°	102.61
11	θ_{11}	59.04°	101.4
12	θ_{12}	64.5°	101.12
13	θ_{13}	70.0°	101.78
14	θ_{14}	75.4°	103.35
15	θ_{15}	80.13°	101.5
16	θ_{16}	90.0°	100.0

* Rotation angle and composite spectrum are calculated values.

Set Current Waveform Model

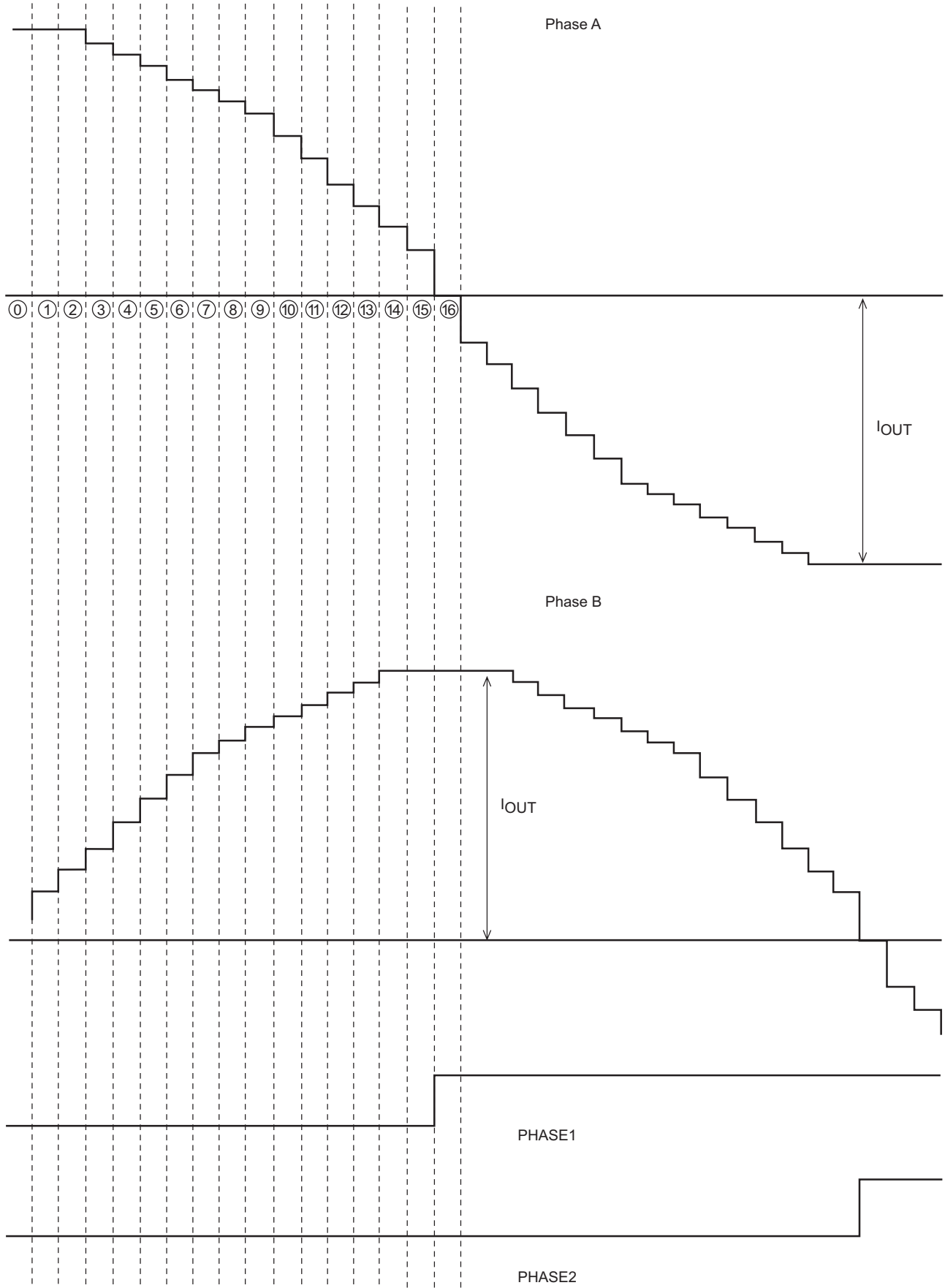

Sample Application Circuit

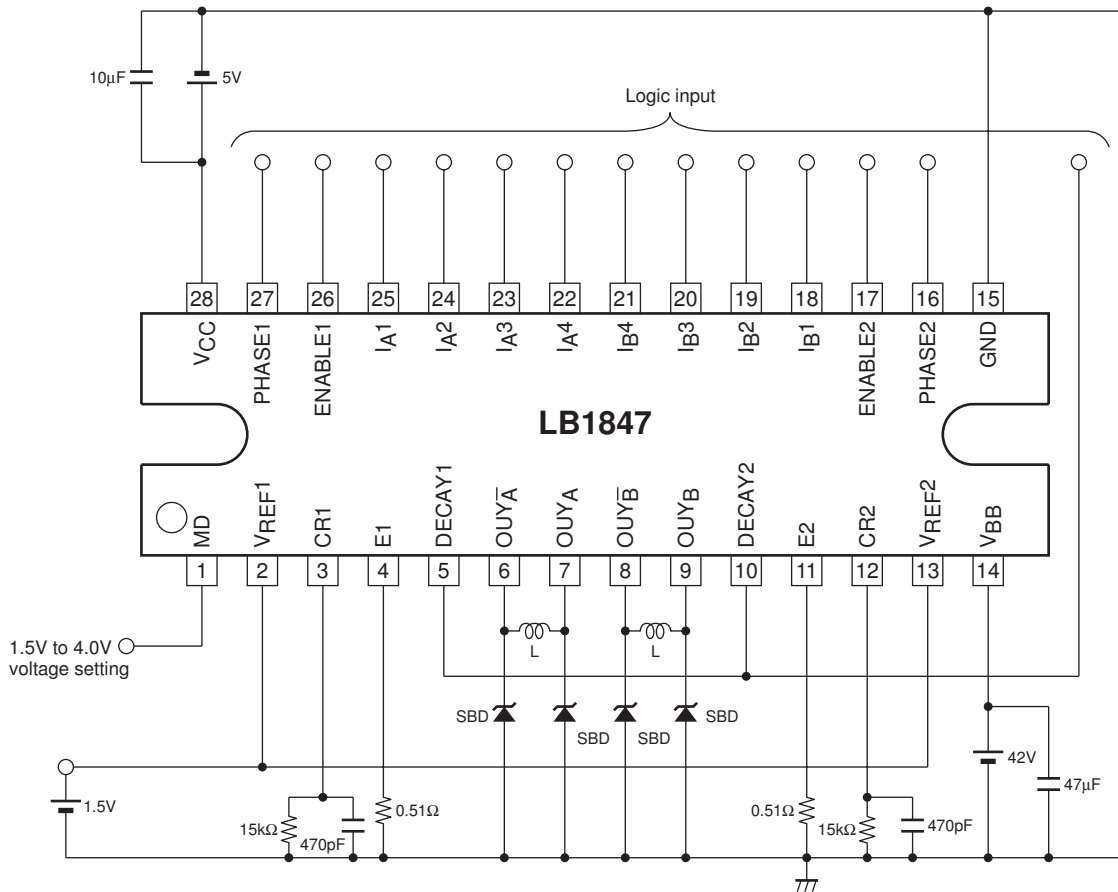

Notes on Usage

1. External diodes

Because this IC uses upper-side transistor switching in SLOW DECAY mode and dual-side transistor switching in FAST DECAY mode, it requires external diodes between the OUT pins and ground, for the regenerative current during switching OFF. Use Schottky barrier diodes with low VF.

2. VREF pin

Because the VREF pin serves for input of the set current reference voltage, precautions against noise must be taken. The input voltage range is 0 to 3.0V.

3. GND pin

The ground circuit for this IC must be designed so as to allow for high-current switching. Blocks where high current flows must use low-impedance patterns and must be removed from small-signal lines. Especially the ground connection for the sensing resistor RE at pin E, and the ground connection for the Schottky barrier diodes should be in close proximity to the IC ground.

The capacitors between VCC and ground, and VBB and ground should be placed close to the VCC and VBB pins, respectively.

4. Simultaneous ON prevention function

This IC incorporates a circuit to prevent feed-through current when phase switching. For reference, the output ON and OFF delay times at PHASE and ENABLE switching are given below.

Reference Data * typical value

		Sink side	Source side
PHASE switching (Low → Hi)	ON delay time	1.9μs	2.2μs
	OFF delay time	0.8μs	1.8μs
PHASE switching (Hi → Low)	ON delay time	1.4μs	1.7μs
	OFF delay time	0.9μs	1.35μs
ENABLE switching	ON delay time	2.15μs	2.75μs
	OFF delay time	1.2μs	5.8μs

5. Noise canceler

This IC has a noise canceling function to prevent malfunction due to noise spikes generated when switching ON. The noise cancel time t_n is determined by internal resistance of the CR pin and the constant of the externally connected CR components. The constant also determines the switching OFF time.

Figure 1 shows the internal configuration at the CR pin, and Figure 2 the CR pin constant setting range.

Equation when logic voltage $V_{CC} = 5V$

$$CR \text{ pin voltage } E1 = V_{CC} \times R / (R1 + R2 + R) \quad [V]$$

$$\text{Noise cancel time } t_n \approx (R1 + R2) \times C \times \ln \{ (E1 - 1.5) / (E1 - 4.0) \} \quad [s]$$

$$\text{Switching OFF time } t_{off} \approx -R \times C \times \ln (1.5 / E1) \quad [s]$$

Internal resistance at CR pin : $R1 = 1k\Omega$, $R2 = 300\Omega$ (typ.)

*The CR constant setting range in Figure 2 on page 15 is given for reference. It applies to a switching OFF time in the range from 8 to 100μs. The switching time can also be made higher than 100 ms. However, a capacitor value of more than several thousand pF will result in longer noise canceling time, which can cause the output current to become higher than the set current. The longer switching OFF time results in higher output current ripple, causing a drop in average current and rotation efficiency. When keeping the switching OFF time within 100 ms, it is recommended to stay within the CR constant range shown in Figure 2.

Internal configuration at CR pin

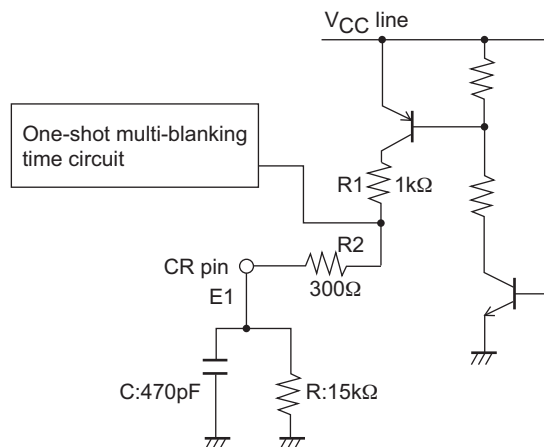
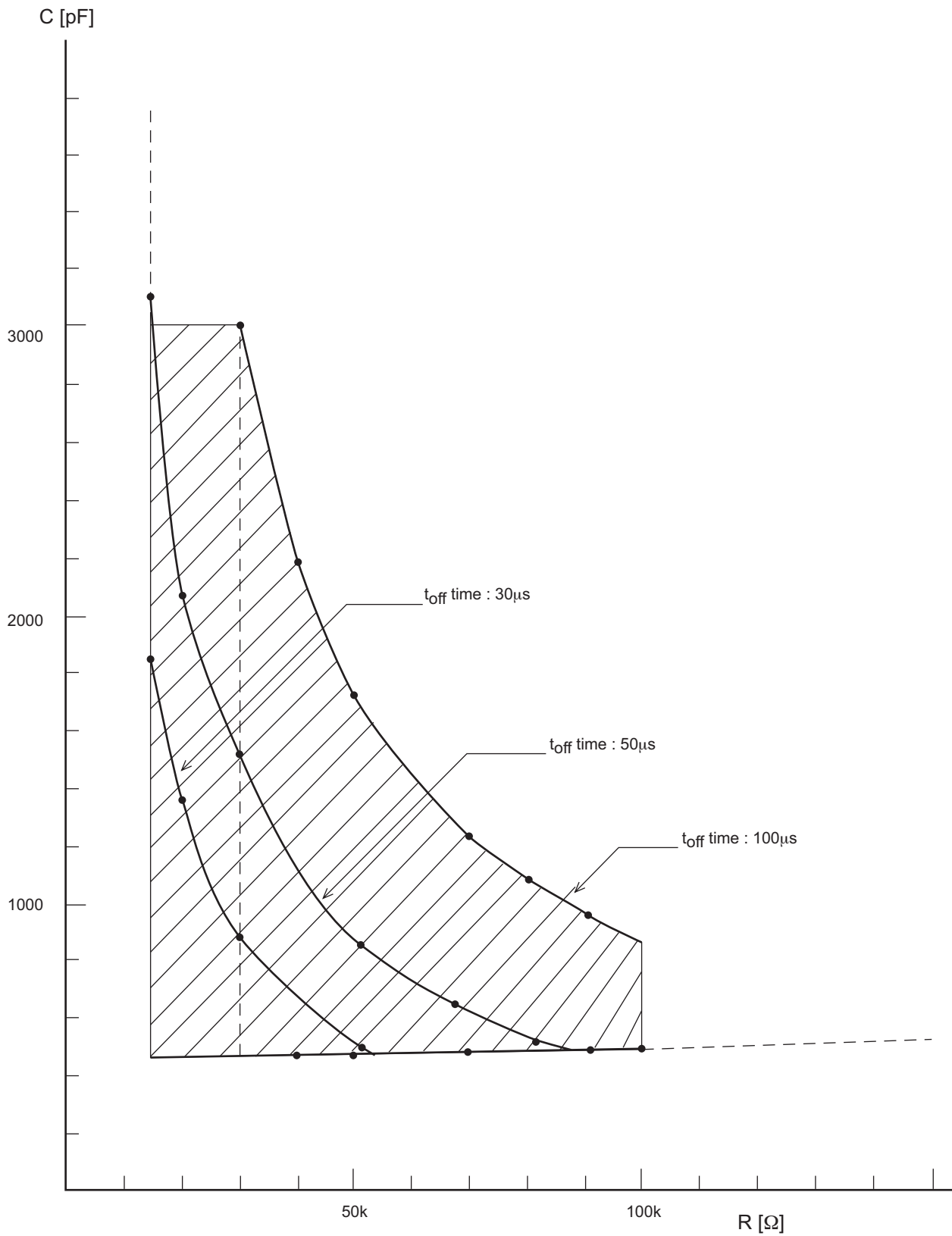

Figure 1

LB1847

Switching OFF time and CR setting range

(t_{off} time : approx. 8 to 100 μ s)



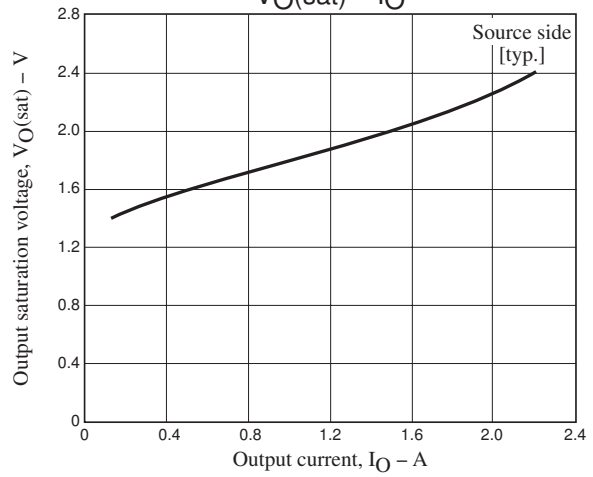
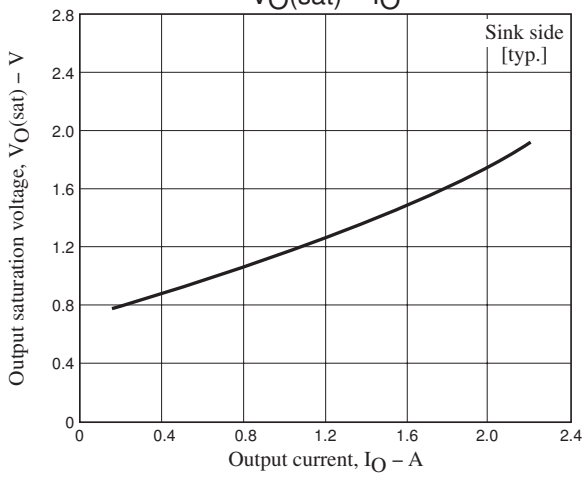
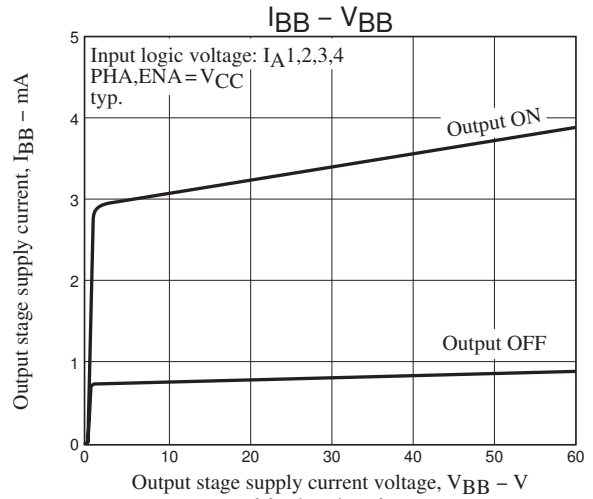
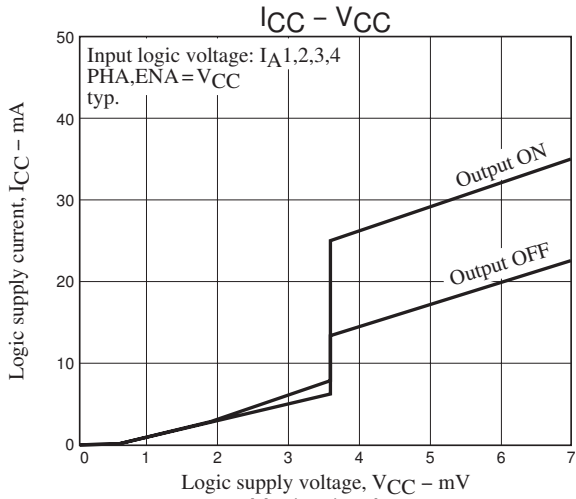

ON Semiconductor and the ON logo are registered trademarks of Semiconductor Components Industries, LLC (SCILLC). SCILLC owns the rights to a number of patents, trademarks, copyrights, trade secrets, and other intellectual property. A listing of SCILLC's product/patent coverage may be accessed at www.onsemi.com/site/pdf/Patent-Marking.pdf. SCILLC reserves the right to make changes without further notice to any products herein. SCILLC makes no warranty, representation or guarantee regarding the suitability of its products for any particular purpose, nor does SCILLC assume any liability arising out of the application or use of any product or circuit, and specifically disclaims any and all liability, including without limitation special, consequential or incidental damages. "Typical" parameters which may be provided in SCILLC data sheets and/or specifications can and do vary in different applications and actual performance may vary over time. All operating parameters, including "Typicals" must be validated for each customer application by customer's technical experts. SCILLC does not convey any license under its patent rights nor the rights of others. SCILLC products are not designed, intended, or authorized for use as components in systems intended for surgical implant into the body, or other applications intended to support or sustain life, or for any other application in which the failure of the SCILLC product could create a situation where personal injury or death may occur. Should Buyer purchase or use SCILLC products for any such unintended or unauthorized application, Buyer shall indemnify and hold SCILLC and its officers, employees, subsidiaries, affiliates, and distributors harmless against all claims, costs, damages, and expenses, and reasonable attorney fees arising out of, directly or indirectly, any claim of personal injury or death associated with such unintended or unauthorized use, even if such claim alleges that SCILLC was negligent regarding the design or manufacture of the part. SCILLC is an Equal Opportunity/Affirmative Action Employer. This literature is subject to all applicable copyright laws and is not for resale in any manner.