



ON Semiconductor®

<http://onsemi.com>

# LB1838JM

Monolithic Digital IC

## Low-Saturation Bidirectional Motor Driver for Low-Voltage Drive

### Overview

The LB1838JM is a low-saturation two-channel bidirectional motor driver IC for use in low-voltage applications. It has a wide operating temperature range of -40 to 80°C and is ideal for 2-phase excitation bipolar stepping motor driver IC used in automotive components (other than critical safety parts), consumer and industrial products, and many other applications.

### Features

- Low voltage operation (2.5V min)
- Low saturation voltage (upper transistor + lower transistor residual voltage ; 0.40V typ at 400mA).
- Through-current prevention circuit built in
- Separate logic power supply and motor power supply
- Spark killer diodes built in
- Thermal shutdown circuit built in
- Compact package (14-pin MFP)

### Specifications

**Absolute Maximum Ratings** at  $T_a = 25^\circ\text{C}$

Parameter	Symbol	Conditions	Ratings	Unit
Maximum supply voltage	$V_{CC\ max}$		-0.3 to +10.5	V
	$V_S\ max$		-0.3 to +10.5	V
Output supply voltage	$V_{OUT}$		$V_S$ to $V_{SF}$	V
Input supply voltage	$V_{IN}$		-0.3 to +10	V
GND pin flow-out current	IGND	Per channel	1.0	A
Allowable power dissipation	$P_d\ max1$	Independent IC	550	mW
	$P_d\ max2$	* Mounted on a board.	800	mW
Operating temperature	$T_{opr}$		-40 to +85	°C
Storage temperature	$T_{stg}$		-55 to +150	°C

\* Mounted on a substrate :  $30 \times 30 \times 1.5\text{mm}^3$ , glass epoxy board.

Stresses exceeding Maximum Ratings may damage the device. Maximum Ratings are stress ratings only. Functional operation above the Recommended Operating Conditions is not implied. Extended exposure to stresses above the Recommended Operating Conditions may affect device reliability.

# LB1838JM

## Allowable Operating Ranges at Ta = 25°C

Parameter	Symbol	Conditions	Ratings	Unit
Supply voltage	V <sub>CC</sub>		2.5 to 9.0	V
	V <sub>S</sub>		1.8 to 9.0	V
Input high-level voltage	V <sub>IH</sub>		1.8 to 9.0	V
Input low-level voltage	V <sub>IL</sub>		-0.3 to +0.7	V

## Electrical Characteristics at Ta = 25°C, V<sub>CC</sub> = 3V

Parameter	Symbol	Conditions	Ratings			Unit
			min	typ	max	
Supply current	I <sub>CC0</sub>	EMA1, 2 = 0V, V <sub>IN1</sub> = 3V or 0V		0.1	10	μA
	I <sub>CC1</sub>	EMA1 = 3V, V <sub>IN1</sub> = 3V or 0V		12	18	mA
Output saturation voltage	V <sub>OUT1</sub>	EMA1 = 3V, V <sub>IN1</sub> = 3V or 0V, I <sub>OUT</sub> = 200mA		0.20	0.28	V
	V <sub>OUT2</sub>	EMA1 = 3V, V <sub>IN1</sub> = 3V or 0V, I <sub>OUT</sub> = 400mA		0.40	0.60	V
Input current	I <sub>IN</sub>	V <sub>CC</sub> = 6V, V <sub>IN</sub> = 6V			200	μA
	I <sub>ENA</sub>	V <sub>CC</sub> = 6V, ENA = 6V			200	μA
Output sustaining voltage	V <sub>O (SUS)</sub>	I <sub>OUT</sub> = 400mA	9			V
<b>Spark killer diode</b>						
Reverse current	I <sub>S (leak)</sub>	V <sub>CC1</sub> , V <sub>S</sub> = 7V			30	μA
Forward voltage	V <sub>SF</sub>	I <sub>OUT</sub> = 400mA			1.7	V

## Package Dimensions

unit : mm (typ)

3111A

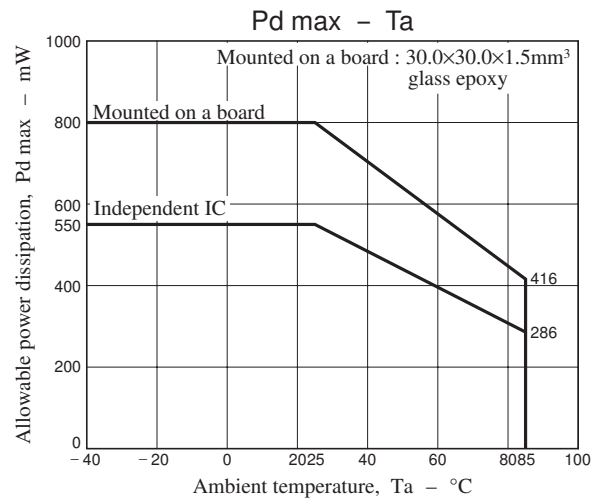
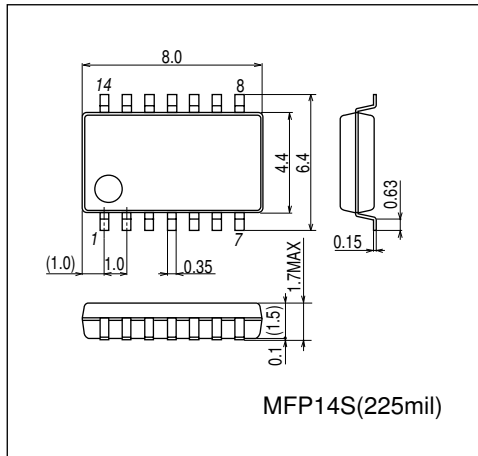

## Pin Assignment

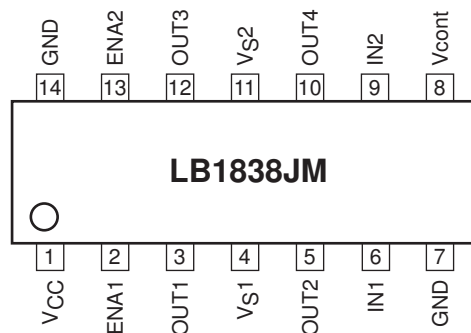

Top view

Note) Ground both GND pins.

# LB1838JM

## Block Diagram

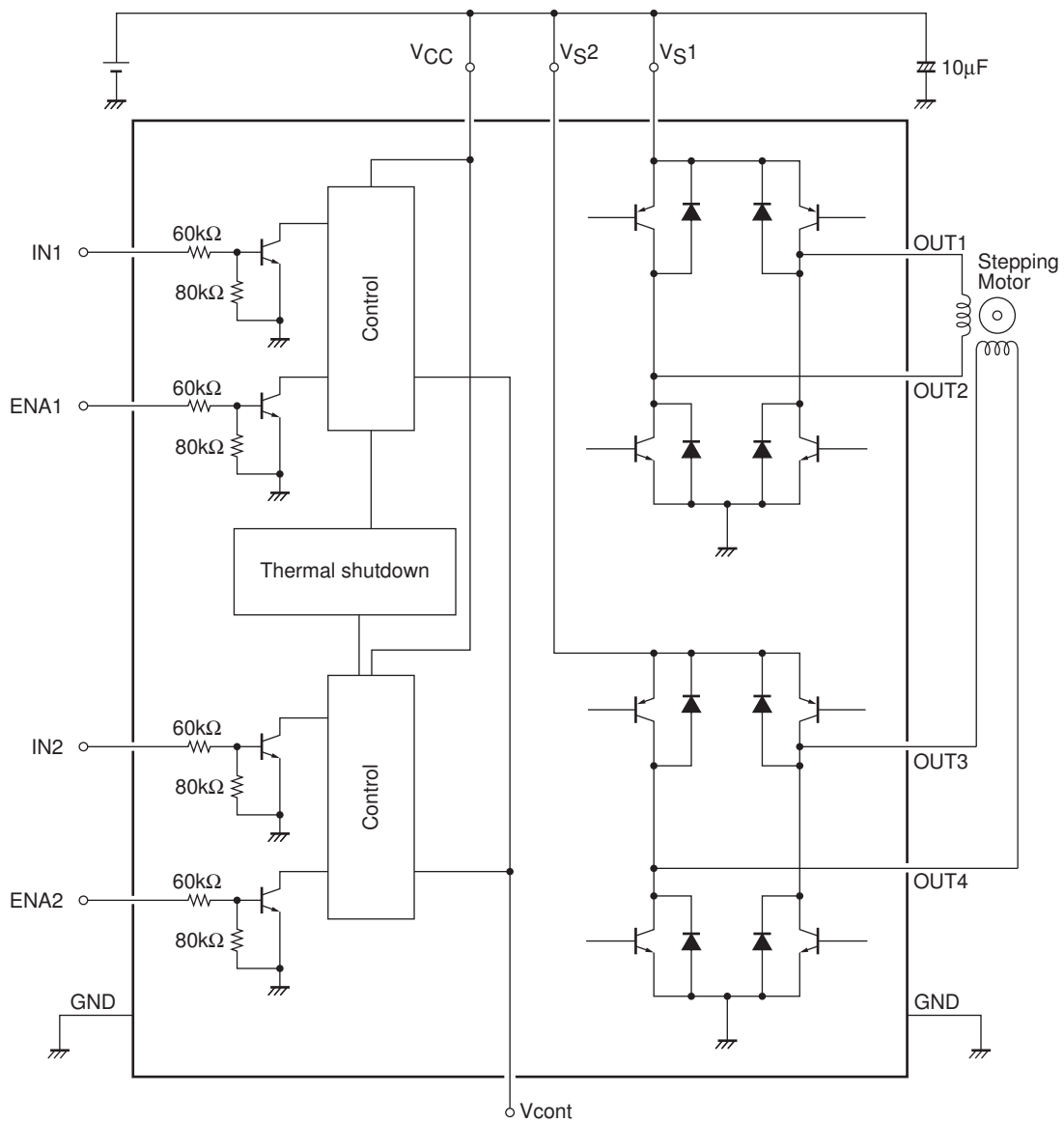

\* : As long as the voltages applied to  $V_{CC}$ ,  $V_{S1}$ ,  $V_{S2}$ ,  $EN_{A1}$ ,  $EN_{A2}$ ,  $IN_1$  and  $IN_2$  are within the limits set by the absolute maximum ratings, there are no restrictions on the relationship of each voltage level in comparison with the others (regarding which is higher or lower). (ex.  $V_{CC} = 3V$ ,  $V_{S1, 2} = 2V$ ,  $EN_A = IN = 5V$ )

### Truth Table

IN1/2	ENA1/2	OUT1/3	OUT2/4	Mode
L	H	H	L	Forward
H	H	L	H	Reverse
L	L	OFF	OFF	Standby
H	L	OFF	OFF	Standby

Vcont pin

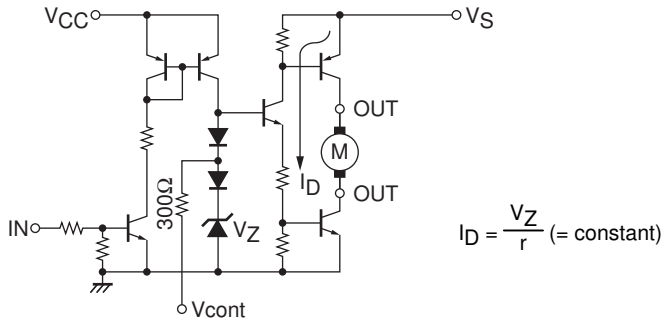

As shown in the above diagram, the Vcont pin outputs the voltage of the band gap Zener  $V_Z + V_F (=1.93V)$ .

In normal use, this pin is left open.

The drive current  $I_D$  is varied by the Vcont voltage. However, because the band gap Zener is shared, it functions as a bridge.

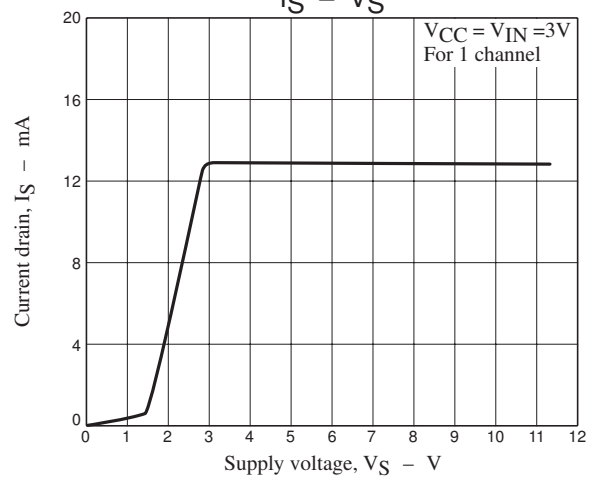
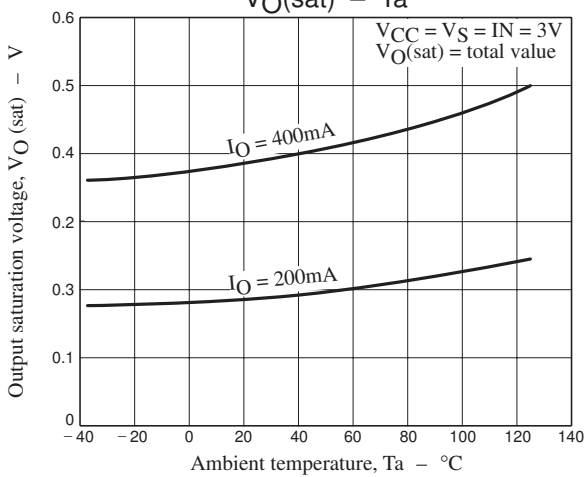
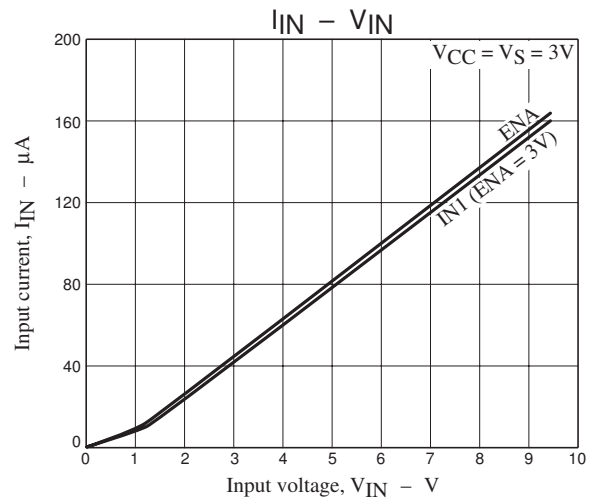
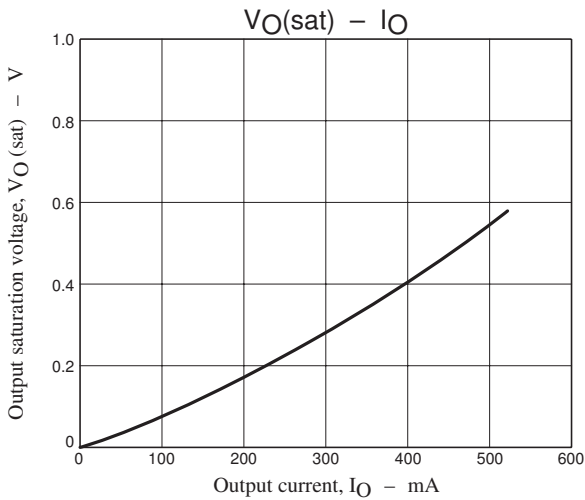

# LB1838JM

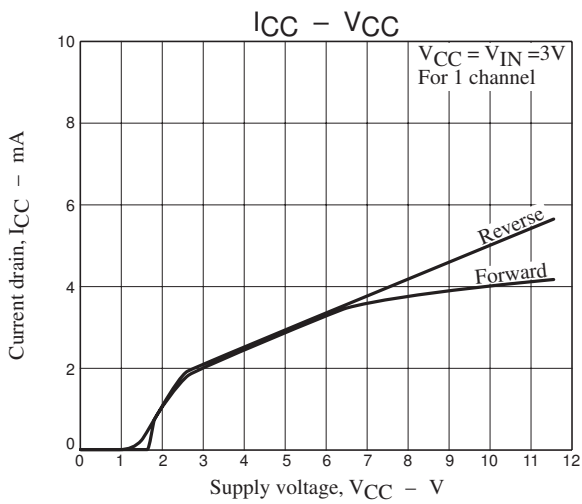

ON Semiconductor and the ON logo are registered trademarks of Semiconductor Components Industries, LLC (SCILLC). SCILLC owns the rights to a number of patents, trademarks, copyrights, trade secrets, and other intellectual property. A listing of SCILLC's product/patent coverage may be accessed at [www.onsemi.com/site/pdf/Patent-Marking.pdf](http://www.onsemi.com/site/pdf/Patent-Marking.pdf). SCILLC reserves the right to make changes without further notice to any products herein. SCILLC makes no warranty, representation or guarantee regarding the suitability of its products for any particular purpose, nor does SCILLC assume any liability arising out of the application or use of any product or circuit, and specifically disclaims any and all liability, including without limitation special, consequential or incidental damages. "Typical" parameters which may be provided in SCILLC data sheets and/or specifications can and do vary in different applications and actual performance may vary over time. All operating parameters, including "Typicals" must be validated for each customer application by customer's technical experts. SCILLC does not convey any license under its patent rights nor the rights of others. SCILLC products are not designed, intended, or authorized for use as components in systems intended for surgical implant into the body, or other applications intended to support or sustain life, or for any other application in which the failure of the SCILLC product could create a situation where personal injury or death may occur. Should Buyer purchase or use SCILLC products for any such unintended or unauthorized application, Buyer shall indemnify and hold SCILLC and its officers, employees, subsidiaries, affiliates, and distributors harmless against all claims, costs, damages, and expenses, and reasonable attorney fees arising out of, directly or indirectly, any claim of personal injury or death associated with such unintended or unauthorized use, even if such claim alleges that SCILLC was negligent regarding the design or manufacture of the part. SCILLC is an Equal Opportunity/Affirmative Action Employer. This literature is subject to all applicable copyright laws and is not for resale in any manner.