



SANYO Semiconductors

DATA SHEET

LV8011V — Bi-CMOS IC

Forward/Reverse Motor Driver

Overview

LV8011V is a 1ch forward/reverse motor driver IC using D-MOS FET for output stage. As MOS circuit is used, it supports the PWM input. Its features are that the on resistance (0.37Ω typ) and current dissipation are low.

It also provides protection functions such as heat protection circuit and reduced voltage detection and is optimal for the motors that need high-current (maximum peak current : 5A).

Absolute Maximum Ratings at $T_a = 25^\circ\text{C}$, SGND = PGND = 0V

Parameter	Symbol	Conditions	Ratings	Unit
Maximum Power Source Voltage (For load)	VM max		-0.5 to 7.5	V
Maximum Power Source Voltage (For control)	V _{CC} max		-0.5 to 6.0	V
Maximum Output Current	I _O max	DC	1.0	A
	I _O peak1	t \leq 100ms, f = 2Hz	3.0	A
	I _O peak2	t \leq 10ms, f = 2Hz	5.0	A
Input Voltage	V _{IN} max		-0.5 to V _{CC} +0.5	V
Operating Temperature	T _{opr}		-20 to +75	°C
Storage Temperature	T _{stg}		-55 to 150	°C
Allowable Power Dissipation	P _d	*Specified substrate	800	mW

* When mounting the glass epoxy substrate 30mm×50mm×1.6mm.

Allowable Operating Range at SGND = PGND = 0V

Parameter	Symbol	Conditions	Ratings	Unit
Power Source Voltage (For load)	VM		2.0 to 6.5	V
Power Source Voltage (For control)	V _{CC}		4.5 to 5.5	V
Input Signal Voltage	V _{IN}		0 to V _{CC}	V
Input Signal Frequency	f max	duty = 50%	100	kHz
Charge-Pump Capacitor	C1, C2, C3		0.001 to 0.1	μF

■ Any and all SANYO Semiconductor products described or contained herein do not have specifications that can handle applications that require extremely high levels of reliability, such as life-support systems, aircraft's control systems, or other applications whose failure can be reasonably expected to result in serious physical and/or material damage. Consult with your SANYO Semiconductor representative nearest you before using any SANYO Semiconductor products described or contained herein in such applications.

■ SANYO Semiconductor assumes no responsibility for equipment failures that result from using products at values that exceed, even momentarily, rated values (such as maximum ratings, operating condition ranges, or other parameters) listed in products specifications of any and all SANYO Semiconductor products described or contained herein.

SANYO Semiconductor Co., Ltd.

TOKYO OFFICE Tokyo Bldg., 1-10, 1 Chome, Ueno, Taito-ku, TOKYO, 110-8534 JAPAN

LV8011V

Electric Characteristics at $T_a = 25^\circ\text{C}$, $V_{CC} = V_M = 5.0\text{V}$, $\text{SGND} = \text{PGND} = 0\text{V}$

Parameter	Symbol	Conditions	Ratings			Unit	Remarks
			min	typ	max		
Standby Power Source Current for Load	IMO	EN = 0V			1.0	μA	1
Standby Power Source Current for Control	ICO	EN = 0V, IN1 = IN2 = TIN = 5V		50	100	μA	2
Operating Current Consumption	IC1	EN = 5V, VG when non-load.		0.7	1.2	mA	3
High Level Input Voltage	V_{IH}		2.5		V_{CC}	V	
Low Level Input Voltage	V_{IL}		0		0.8	V	
High Level Input Current (IN1, IN2)	I_{IH}				1.0	μA	4
Low Level Input Current (IN1, IN2)	I_{IL}		-1.0			μA	
Pull-up Resistance Value (EN, TIN)	RUP		50	100	200	$\text{k}\Omega$	
Output ON Resistance	RON	Sum of top and bottom of ON resistance value.		0.37	0.60	Ω	5
Charge-Pump Voltage	VG		9.5	10.4	11	V	6
Low Voltage Detection Operating Voltage	VCS	V_{CC} Voltage	2.3	2.5	2.7	V	7
Thermal Shutdown Operating Temperature	TTSD	*Design Target	150	180	210	$^\circ\text{C}$	8
Charge-Pump Capacity (IG = 500 μA)	VGLOAD		9.0	9.9		V	9
IG Current Dissipation (Fin = 20kHz)	IG				350	μA	10
Charge Pump Start-up Time	TVG	C1 = C2 = 0.01 μF , CVG = 0.1 μF		0.5	1.0	ms	11
[Output Part]							
Turn-ON Time	TPLH			0.9	2.0	μs	12
Turn-OFF Time	TPHL			0.3	2.0	μs	12
[TOUT]							
Turn-ON Time	TOUT	C = 500pF		5.0	20	μs	12
Turn-OFF Time	TOFF	C = 500pF		5.0	20	μs	12

* It is a design target value and measurement is not carried out.

Remarks

1. It shows current dissipation of VM pin in output OFF state.
2. It shows current dissipation of V_{CC} pin in stand-by state.
(The standard current depends on EN pin pull-down resistance.)
3. It shows current dissipation of V_{CC} pin in state of EN = 5V (stand-by), including current dissipation of VG pin.
4. For IN1 and IN2 pins, no pull-down and pull-up resistance is needed. (High impedance pin)
5. It shows sum of upper and lower saturation voltages of OUT pin.
6. It controls charge-pump oscillation and makes specified voltage.
7. When low voltage is detected, the lower output is turned OFF.
8. When thermal protection circuit is activated, the lower output is turned OFF.
When the heat temperature is fallen, it is turned ON again.
9. IG (VG pin load current) = 500 μF
10. It shows VG pin current dissipation in state of PWM input for IN pin.
11. It specifies start-up time from 10% to 90% when VG is in non-load state
(when setting the capacitor between VG and GND to 0.1 μF and V_{CC} is 5V).
12. It specifies 10% to 90% for start-up and 90% to 10% for shut-down.

LV8011V

Package Dimensions

unit : mm
3179B

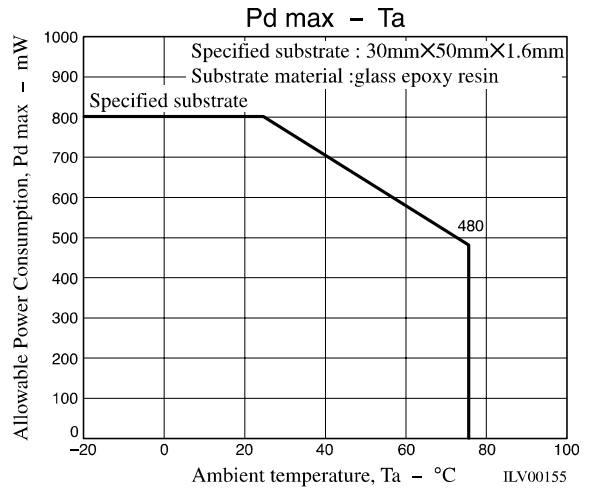
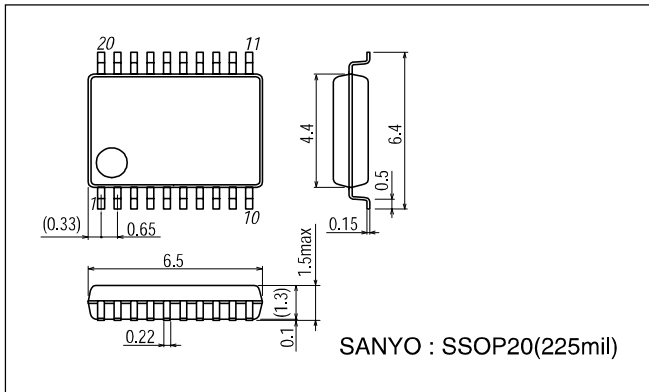

Pin Assignment

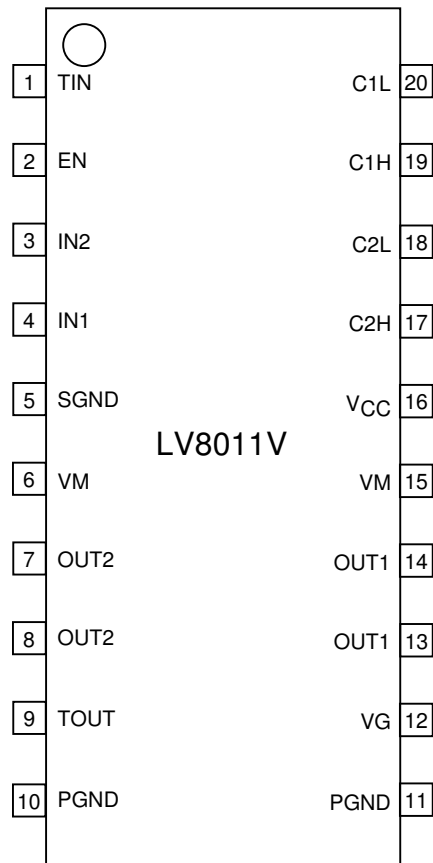

Top view

Block Diagram

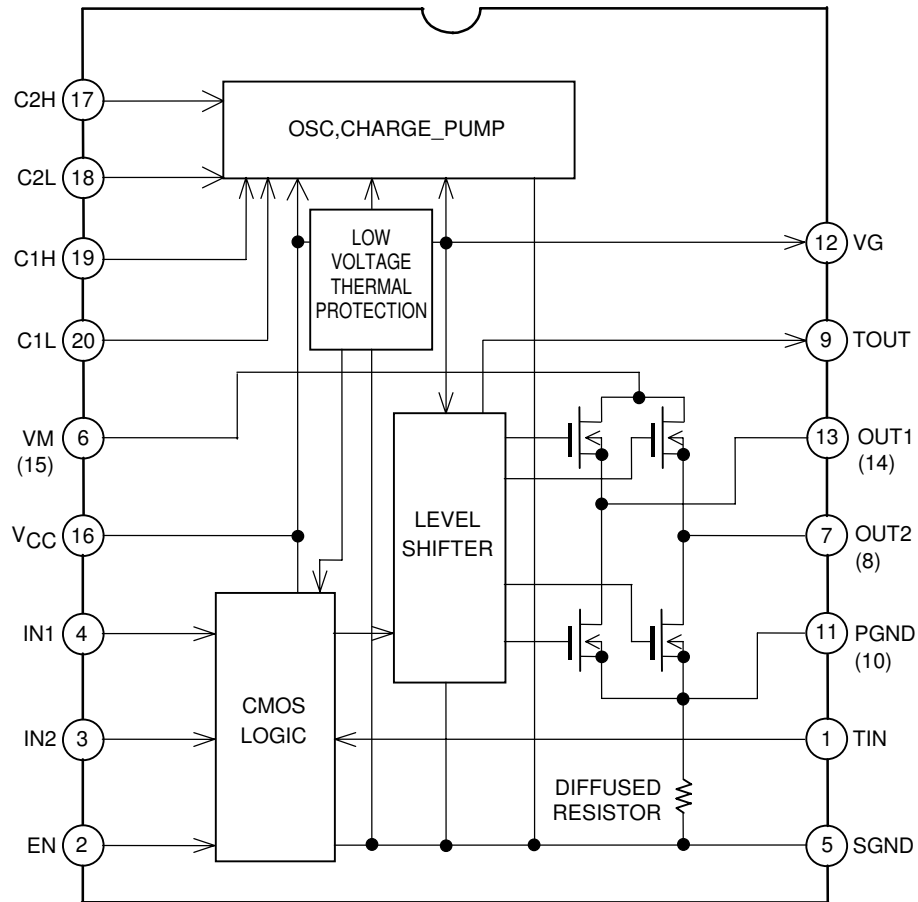

True Value Table

Z : High-Impedance - : Don't care

EN	IN1	IN2	TIN	OUT1	OUT2	TOUT	Mode
H	H	H	-	L	L	-	Brake
H	H	L	-	H	L	-	Forward evolution
H	L	H	-	L	H	-	Reverse rotation
H	L	L	-	Z	Z	-	Stand by
L	-	-	-	L	L	L	Stdby
H	-	-	H	-	-	L	TR-OFF
H	-	-	L	-	-	H	TR-ON

* For reduced voltage and thermal protection, the lower output is turned OFF and the motor drive stops.

LV8011V

Pin Description

Pin no.	Pin name	Equivalent Circuit	Pin Explanation
20 18	C1L C2L		Step-up Capacitor Connection Pin
19 17	C1H C2H		Step-up Capacitor Connection Pin
4 3	IN1 IN2		Driver Output Switch
2 1	EN TIN		Logic Enable Pin TOUT Output Control Pin (Built-in Pull-up Resistance)
13 14 7 8	OUT1 OUT2		Driver Output Pin (Both 2 pins are Connected.)

Continued on next page.

LV8011V

Continued from preceding page.

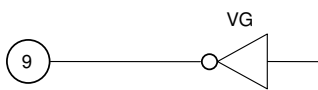
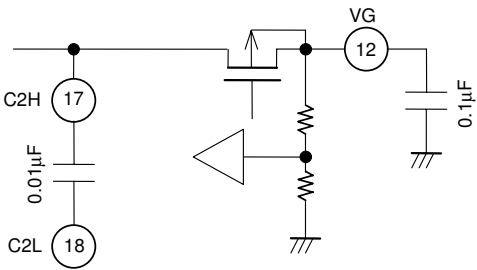
Pin no.	Pin name	Equivalent Circuit	Pin Explanation
9	TOUT		Step-up Voltage Output Pin
6 15	VM		Driver Power Source (Both 2 pins are Connected.)
16	V _{CC}		Logic Power Source
12	VG		Driving Circuit Unit Power Source for Driver
5	SGND		Logic GND
10 11	PGND		Driver GND (Both 2 pins are Connected.)

Application Circuit Diagram

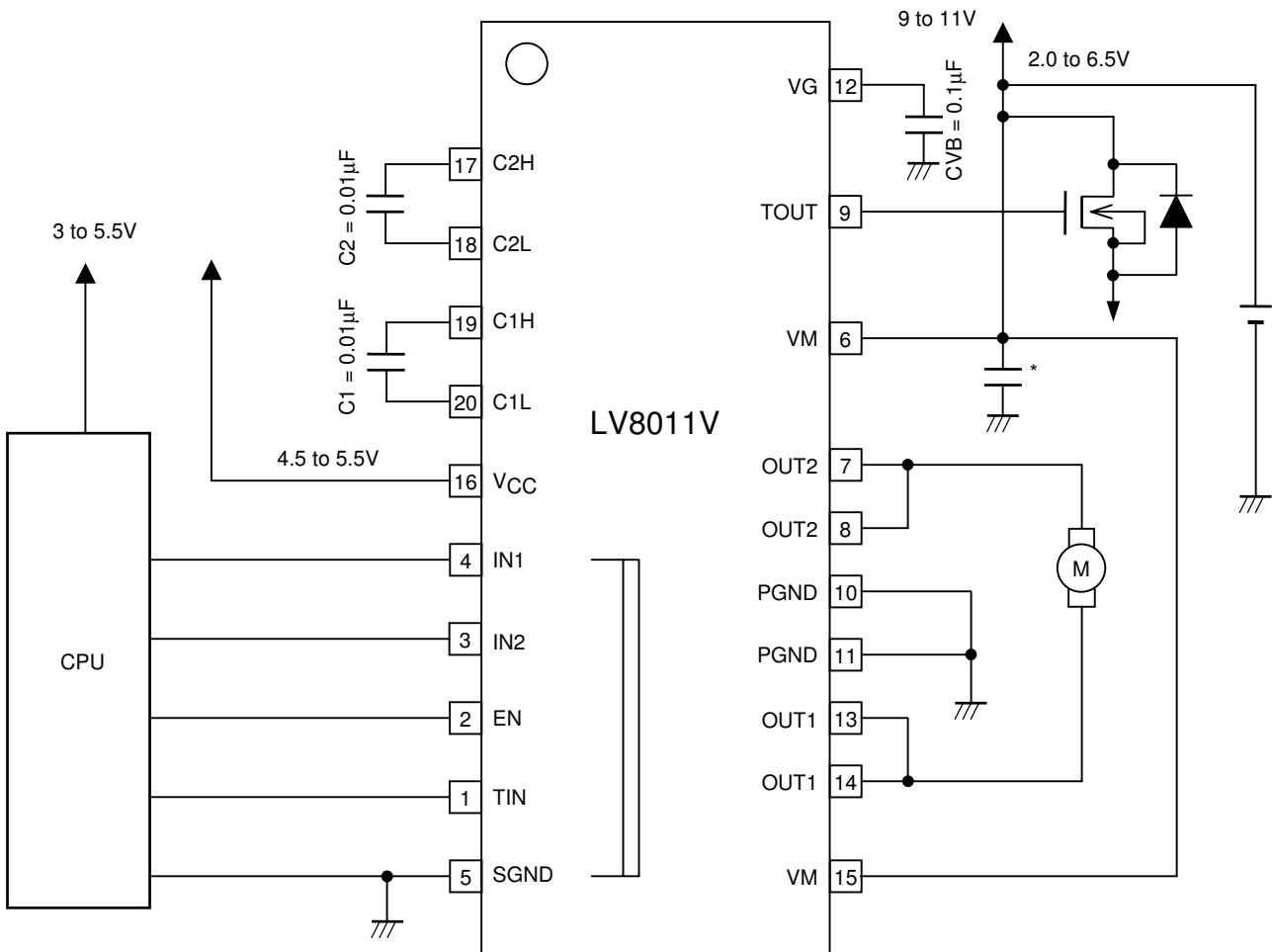

* Place it as close as possible to VM and PGND pins of IC.

- Specifications of any and all SANYO Semiconductor products described or contained herein stipulate the performance, characteristics, and functions of the described products in the independent state, and are not guarantees of the performance, characteristics, and functions of the described products as mounted in the customer's products or equipment. To verify symptoms and states that cannot be evaluated in an independent device, the customer should always evaluate and test devices mounted in the customer's products or equipment.
- SANYO Semiconductor Co., Ltd. strives to supply high-quality high-reliability products. However, any and all semiconductor products fail with some probability. It is possible that these probabilistic failures could give rise to accidents or events that could endanger human lives, that could give rise to smoke or fire, or that could cause damage to other property. When designing equipment, adopt safety measures so that these kinds of accidents or events cannot occur. Such measures include but are not limited to protective circuits and error prevention circuits for safe design, redundant design, and structural design.
- In the event that any or all SANYO Semiconductor products (including technical data, services) described or contained herein are controlled under any of applicable local export control laws and regulations, such products must not be exported without obtaining the export license from the authorities concerned in accordance with the above law.
- No part of this publication may be reproduced or transmitted in any form or by any means, electronic or mechanical, including photocopying and recording, or any information storage or retrieval system, or otherwise, without the prior written permission of SANYO Semiconductor Co., Ltd.
- Any and all information described or contained herein are subject to change without notice due to product/technology improvement, etc. When designing equipment, refer to the "Delivery Specification" for the SANYO Semiconductor product that you intend to use.
- Information (including circuit diagrams and circuit parameters) herein is for example only; it is not guaranteed for volume production. SANYO Semiconductor believes information herein is accurate and reliable, but no guarantees are made or implied regarding its use or any infringements of intellectual property rights or other rights of third parties.

This catalog provides information as of September, 2004. Specifications and information herein are subject to change without notice.