



ON Semiconductor®

<http://onsemi.com>

LB11685AV

Monolithic Digital IC

3-phase sensor less Motor driver

Overview

The LB11685AV is a three-phase full-wave current-linear-drive motor driver IC. It adopts a sensor less control system without the use of a Hall Effect device. For quieter operation, the LB11685AV features a current soft switching circuit and be optimal for driving the cooling fan motors used in refrigerators, etc.

Functions

- Three-phase full-wave linear drive (Hall sensor-less method)
- Built-in three-phase output voltage control circuit
- Motor lock protection detection output
- Built-in thermal shut down circuit
- Built-in current limiter circuit
- Built-in motor lock protection circuit
- FG output made by back EMF
- Beat lock prevention circuit

Specifications

Maximum Ratings at $T_a = 25^\circ\text{C}$

Parameter	Symbol	Conditions	Ratings	Unit
Maximum supply voltage	$V_{CC\ max}$		19	V
Input applied voltage	$V_{IN\ max}$		-0.3 to $V_{CC} + 0.3$	V
Maximum output current	$I_O\ max\ ^*1$		1.2	A
Allowable power dissipation	$P_d\ max$	Mounted on a board *2	1.05	W
Operating temperature	T_{opr}		-40 to 85	$^\circ\text{C}$
Storage temperature	T_{stg}		-55 to 150	$^\circ\text{C}$
Junction temperature	$T_j\ max$		150	$^\circ\text{C}$

*1: The I_O is a peak value of motor-current.

*2: Specified board: 76.1mm × 114.3mm × 1.6mm, glass epoxy board.

Caution 1) Absolute maximum ratings represent the value which cannot be exceeded for any length of time.

Caution 2) Even when the device is used within the range of absolute maximum ratings, as a result of continuous usage under high temperature, high current, high voltage, or drastic temperature change, the reliability of the IC may be degraded. Please contact us for the further details.

Stresses exceeding Maximum Ratings may damage the device. Maximum Ratings are stress ratings only. Functional operation above the Recommended Operating Conditions is not implied. Extended exposure to stresses above the Recommended Operating Conditions may affect device reliability.

LB11685AV

Recommended Operating Conditions at Ta = 25°C

Parameter	Symbol	Conditions	Ratings	Unit
Recommended Supply voltage	V _{CC}		12.0	V
Operating supply voltage	V _{CC op}		4.5 to 18.0	V

Electrical Characteristics at Ta = 25°C, V_{CC} = 5.0V

Parameter	Symbol	Conditions	Ratings			Unit
			min	typ	max	
Supply current	I _{CC}	FC1 = FC2 = 0V	5	10	20	mA
Internal regulate voltage	VREG		3.0	3.3	3.6	V
Output voltage (source)	VOSOUR	I _O = 0.8A *3		1.3	1.7	V
Output voltage (sink)	VOSINK	I _O = 0.8A *3		0.5	1.3	V
Current limiter	VOLIM		0.268	0.300	0.332	V
MCOM pin common-input voltage range	VINCOM		0		V _{CC} - 2	V
MCOM pin Source current for hysteresis	ICOM+	MCOM = 7V	30		80	μA
MCOM pin Sink current for hysteresis	ICOM-	MCOM = 7V	30		80	μA
MCOM pin hysteresis current ratio	RTCOM	RTCOM = ICOM+ / ICOM-	0.6		1.4	
VCO input bias current	I _{VCO}	V _{CO} = 2.3V			0.2	μA
VCO oscillation minimum frequency	f _{VCOmin}	V _{CO} = 2.1V, CX = 0.015μF Design target *2		930		Hz
VCO oscillation maximum frequency	f _{VCOmax}	V _{CO} = 2.7V, CX = 0.015μF Design target *2		8.6		kHz
CX charge / discharge current	I _{CX}	V _{CO} = 2.5V, CX = 1.6V	70	100	140	μA
CX hysteresis voltage	ΔVCX		0.35	0.55	0.75	
C1 (C2) charge current	IC1(2)+	V _{CO} = 2.5V, C1(2) = 1.3V	12	20	28	μA
C1 (C2) discharge current	IC1(2)-	V _{CO} = 2.5V, C1(2) = 1.3V	12	20	28	μA
C1 (C2) charge / discharge current ratio	RTC1(2)	RTC1(2) = IC1(2)+ / IC1(2)-	0.8	1.0	1.2	
C1/C2 charge current ratio	RTCCHG	RTCCHG = IC1+ / IC2+	0.8	1.0	1.2	
C1/C2 discharge current ratio	RTCDIS	RTCDIS = IC1- / IC2-	0.8	1.0	1.2	
C1 (C2) clamp voltage width	VCW1(2)		1.0	1.3	1.6	V
FG output low level voltage	VFGL	IFG = 3mA			0.5	V
RD output low level voltage	VRDL	IRD = 3mA			0.5	v
Thermal shut down operating temperature *1	TTSD	Junction temperature Design target *2	150	180		°C
Thermal shut down hysteresis temperature *1	ΔTTSD	Junction temperature Design target *2		15		°C

*1: The thermal shut down circuit is built-in for protection from damage of IC. But its operation is out of Topr. Design thermal calculation at normal operation.

*2: Design target value and no measurement is made.

*3: The I_O is a peak value of motor-current.

Package Dimensions

unit : mm (typ)
3315

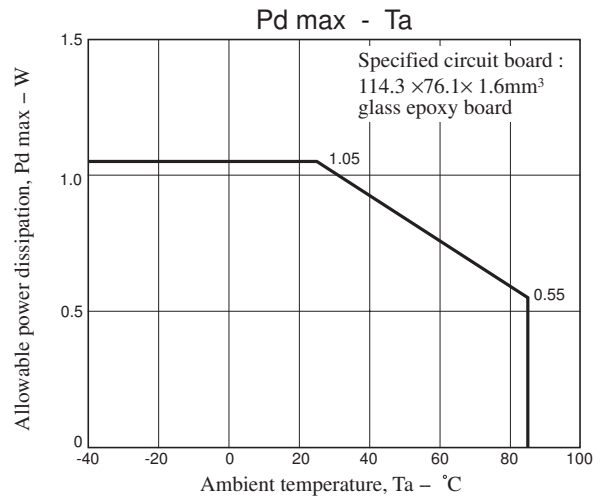
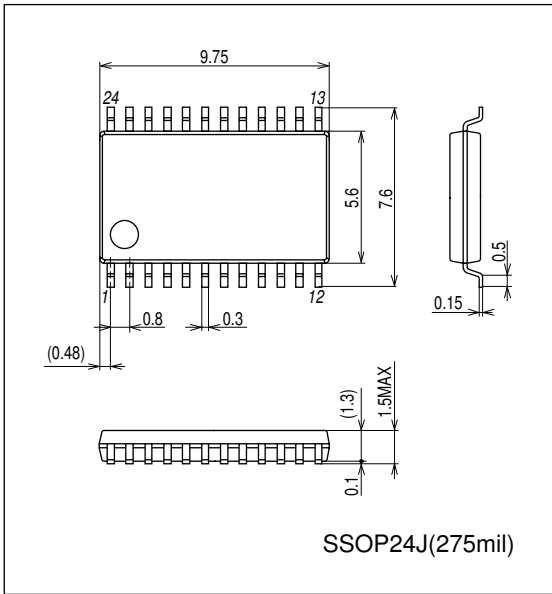

Pin Assignment

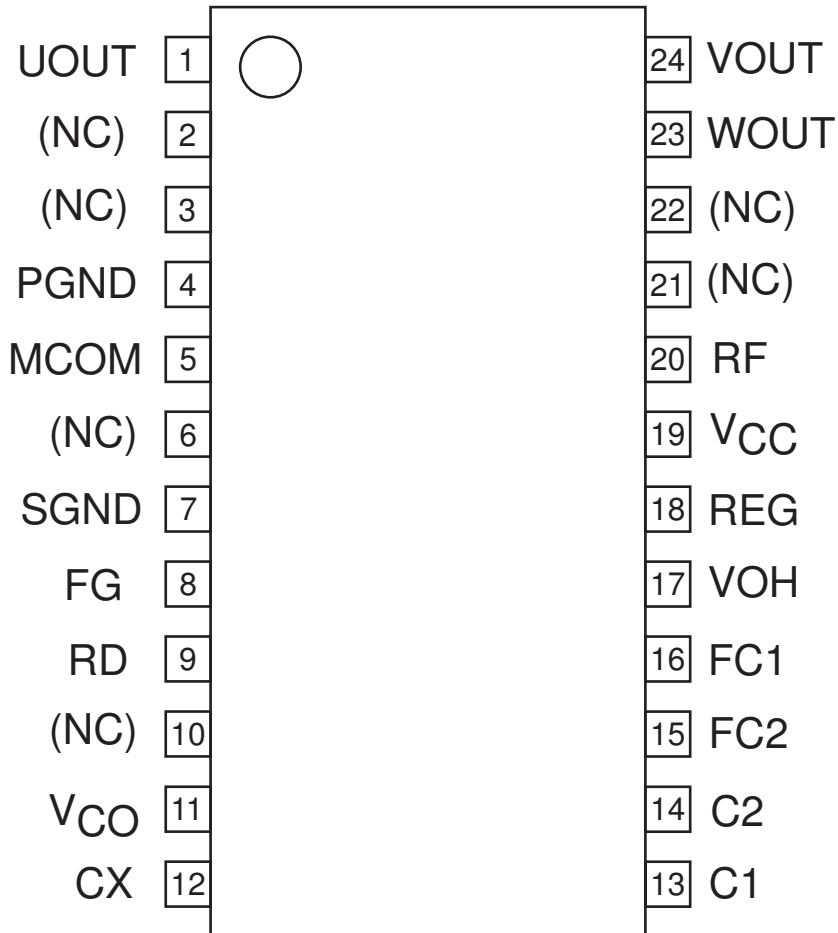

Block Diagram

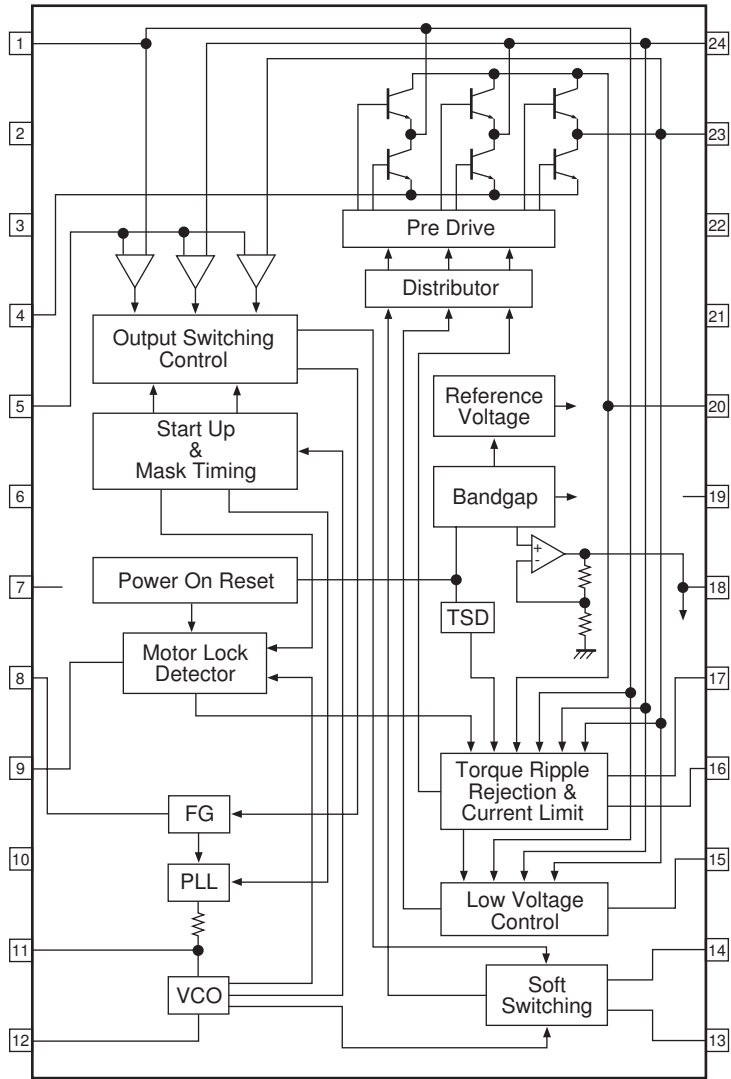

Pin Function

Pin No.	Pin name	Function	Equivalent circuit
1 23 24	UOUT WOUT VOUT	Each output pin of three phases.	
4	PGND	GND pin in the output part. This pin is connected to GND. The SGND pin is also connected to GND	
20	RF	Pin to detect output current. By connecting a resistor between this pin and V_{CC} , the output current is detected as a voltage. The current limiter is operated by this voltage.	
5	MCOM	Motor coil midpoint input pin. The coil voltage waveform is detected based on this voltage.	
7	SGND	Ground pin (except the output part) This pin is connected to GND. The PGND pin is also connected to GND.	
8	FG	FG out made by back EMF pin. It synchronizes FG out with inverted V-phase. When don't use this function, open this pin.	
9	RD	Motor lock protection detection output pin. Output with L during rotation of motor. Open during lock protection of motor (High-impedance). When don't use this function, open this pin.	
11	VCO	PLL output pin and VCO input pin. To stabilize PLL output, connect a capacitor between this pin and GND.	
12	CX	VCO oscillation output pin. Operation frequency range and minimum frequency are determined by the capacity of the capacitor connected to this pin.	

Continue to the next page.

LB11685AV

Continue from the former page.

Pin No.	Pin name	Function	Equivalent circuit
13 14	C1 C2	Soft switching adjustment pin. The triangular wave from is form formed by connecting a capacitor with this pin. And, the switching of three-phase output is adjusted by the slope.	
15	FC2	Frequency characteristic correction pin 2. To suppress the oscillation of control system closed loop of sink-side, connect a capacitor between this pin and GND.	
16	FC1	Frequency characteristic correction pin 1. To suppress the oscillation of control system closed loop of source-side, connect a capacitor between this pin and GND.	
17	VOH	Three-phase output high level output pin. To stabilize the output voltage of this pin, connect a capacitor between this pin and the V _{CC} pin.	
18	VREG	DC voltage (3.3V) output pin. Connect a capacitor between this pin and GND for stabilization.	
19	VCC	Pin to supply power-supply voltage. To curb the influence of ripple and noise. The voltage should be stabilized.	

Application Circuit Example

* Each fixed number in the following FIG, is the referential value.

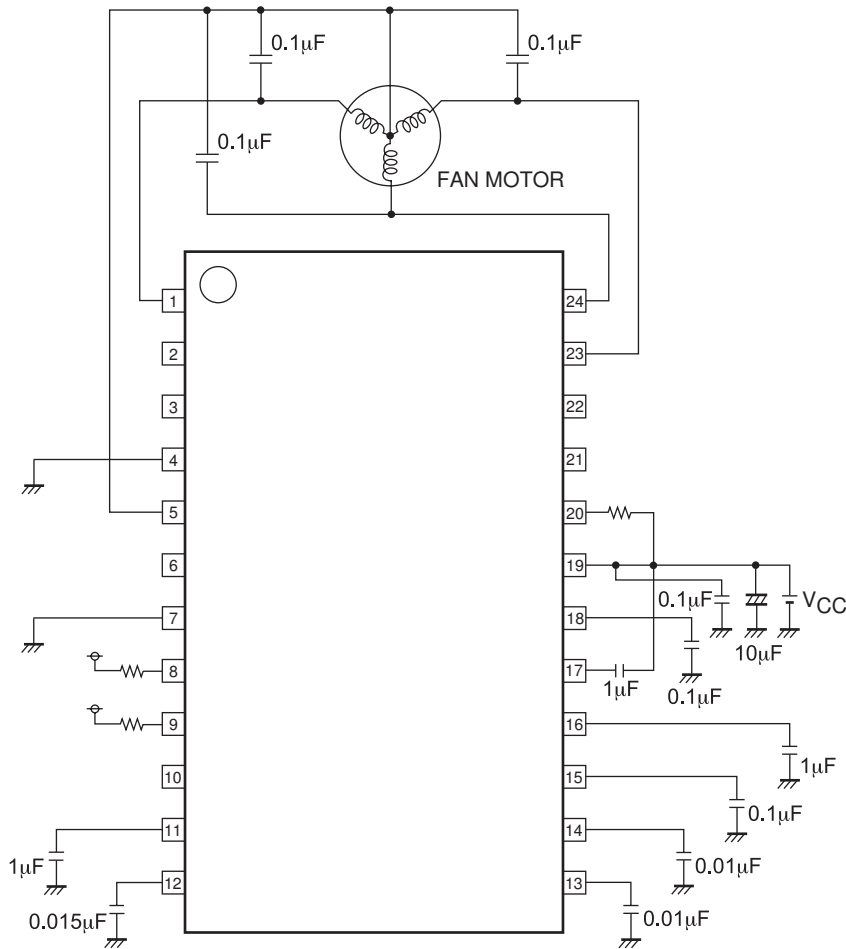

ON Semiconductor and the ON logo are registered trademarks of Semiconductor Components Industries, LLC (SCILLC). SCILLC owns the rights to a number of patents, trademarks, copyrights, trade secrets, and other intellectual property. A listing of SCILLC's product/patent coverage may be accessed at www.onsemi.com/site/pdf/Patent-Marking.pdf. SCILLC reserves the right to make changes without further notice to any products herein. SCILLC makes no warranty, representation or guarantee regarding the suitability of its products for any particular purpose, nor does SCILLC assume any liability arising out of the application or use of any product or circuit, and specifically disclaims any and all liability, including without limitation special, consequential or incidental damages. "Typical" parameters which may be provided in SCILLC data sheets and/or specifications can and do vary in different applications and actual performance may vary over time. All operating parameters, including "Typicals" must be validated for each customer application by customer's technical experts. SCILLC does not convey any license under its patent rights nor the rights of others. SCILLC products are not designed, intended, or authorized for use as components in systems intended for surgical implant into the body, or other applications intended to support or sustain life, or for any other application in which the failure of the SCILLC product could create a situation where personal injury or death may occur. Should Buyer purchase or use SCILLC products for any such unintended or unauthorized application, Buyer shall indemnify and hold SCILLC and its officers, employees, subsidiaries, affiliates, and distributors harmless against all claims, costs, damages, and expenses, and reasonable attorney fees arising out of, directly or indirectly, any claim of personal injury or death associated with such unintended or unauthorized use, even if such claim alleges that SCILLC was negligent regarding the design or manufacture of the part. SCILLC is an Equal Opportunity/Affirmative Action Employer. This literature is subject to all applicable copyright laws and is not for resale in any manner.