



ON Semiconductor®

<http://onsemi.com>

LB1976

Monolithic Digital IC
For Fan Motor

3-phase Brushless Motor Driver

Overview

The LB1976 is a 3-phase brushless motor driver IC suited for use in direct PWM driving of DC fan motors for air conditioners, water heaters, and other similar equipment. Since a shunt regulator circuit is built in, single power supply operation sharing the same power supply for the motor is supported.

Features

- Withstand voltage 60V, output current 2.5A
- Direct PWM drive output
- 3 built-in output top-side diodes
- Built-in current limiter
- Built-in FG output circuit

Specifications

Absolute Maximum Ratings at $T_a = 25^\circ\text{C}$

Parameter	Symbol	Conditions	Ratings	Unit
Supply voltage	V_{CC} max		7	V
	V_M max		60	V
Output current	I_O max		2.5	A
Maximum input current	I_{REG} max	V_{REG} pin	10	mA
Allowable power dissipation	P_d max1	Independent IC	3	W
	P_d max2	With infinite heat sink	20	W
Operating temperature	T_{opr}		-20 to +100	$^\circ\text{C}$
Storage temperature	T_{stg}		-55 to +150	$^\circ\text{C}$

Stresses exceeding Maximum Ratings may damage the device. Maximum Ratings are stress ratings only. Functional operation above the Recommended Operating Conditions is not implied. Extended exposure to stresses above the Recommended Operating Conditions may affect device reliability.

LB1976

Allowable Operating Ranges at $T_a = 25^\circ\text{C}$

Parameter	Symbol	Conditions	Ratings	Unit
Supply voltage range	V_{CC}		4.5 to 6.7	V
	V_M		20 to 56	V
Input current range	I_{REG}	V_{REG} pin	1 to 5	mA
FG pin applied voltage	V_{FG}		0 to V_{CC}	V
FG pin output current	I_{FG}		0 to 10	mA

Electrical Characteristics at $T_a = 25^\circ\text{C}$, $V_{CC} = 5\text{V}$, $V_M = 45\text{V}$

Parameter	Symbol	Conditions	Ratings			Unit
			min	typ	max	
Supply current	I_{CC}		10	14	18	mA
Output Block						
Output saturation voltage	$V_{Osat1(L)}$	$I_O = 1.0\text{A}$, $V_O(\text{sink})$		1.1	1.4	V
	$V_{Osat1(H)}$	$I_O = 1.0\text{A}$, $V_O(\text{source})$		0.9	1.3	V
	V_{Osat1}	$I_O = 1.0\text{A}$, $V_O(\text{sink}) + V_O(\text{source})$		2.0	2.6	V
	$V_{Osat2(L)}$	$I_O = 2.0\text{A}$, $V_O(\text{sink})$		1.4	1.8	V
	$V_{Osat2(H)}$	$I_O = 2.0\text{A}$, $V_O(\text{source})$		1.2	1.7	V
	V_{Osat2}	$I_O = 2.0\text{A}$, $V_O(\text{sink}) + V_O(\text{source})$		2.6	3.4	V
Output leak current	$I_{OLeak(L)}$				100	μA
	$I_{OLeak(H)}$		-100			μA
Upper side diode forward voltage	V_{FH1}	$I_O = 1.0\text{A}$		1.2	1.6	V
	V_{FH2}	$I_O = 2.0\text{A}$		2.1	2.6	V
Hall Amplifier						
Input bias current	I_{HB}		-4	-1		μA
Common-mode input voltage range	V_{ICM}		1.5		$V_{CC}-1.5$	V
Hall input sensitivity	V_{HIN}		60			mVp-p
Hysteresis width	$\Delta V_{IN(HA)}$		23	32	39	mV
Input voltage (low to high)	V_{SLH}		6	16	25	mV
Input voltage (high to low)	V_{SHL}		-25	-16	-6	mV
FG Pin (speed pulse output)						
Output low-level voltage	V_{FGL}	$I_{FG} = 5\text{mA}$			0.5	V
Pull-up resistor value	R_{FG}		7.5	10	12.5	k Ω
Current Limiter						
Limiter	V_{RF}		0.45	0.50	0.55	V
Thermal Shutdown						
Thermal shutdown operating temperature	TSD	Design target Value (junction temperature)	150	180		$^\circ\text{C}$
Hysteresis width	ΔTSD	Design target Value (junction temperature)		40		$^\circ\text{C}$
Low-Voltage Protection						
Operating voltage	V_{LVSD}		3.5	3.8	4.1	V
Non-operating voltage	$V_{LVSD(OFF)}$			4.3	4.5	V
Hysteresis width	ΔV_{LVSD}		0.4	0.5	0.6	V
PWM Oscillator						
Output high-level voltage	$V_{OH(OSC)}$		2.95	3.10	3.25	V
Output low-level voltage	$V_{OL(OSC)}$		1.38	1.45	1.59	V
Amplitude	V_{OSC}		1.50	1.65	1.71	Vp-p
Oscillator frequency	f_{OSC}	$C = 2200\text{pF}$	19.6	23.0	27.6	kHz
Charge current	I_{CHG}		-110	-94	-83	μA
Discharge resistance	R_{DCHG}		1.6	2.1	2.6	k Ω
V_{REG} Pin						
Pin voltage	V_{REG}	$I_{REG} = 1.5\text{mA}$	6.6	7.0	7.2	V

Continued on next page.

LB1976

Continued from preceding page.

Parameter	Symbol	Conditions	Ratings			Unit
			min	typ	max	
VCTL Pin						
Input voltage	V _{CTL1}	Output duty 0%	1.1	1.4	1.7	V
	V _{CTL2}	Output duty 100%	3.2	3.5	3.8	V
Input bias current	I _{B1} (CTL)	V _{CTL} = 0V	-82			μA
	I _{B2} (CTL)	V _{CTL} = 5V			92	μA
VCTL Amplifier						
Reference voltage	V _{CREF}		2.23	2.35	2.46	V
Output voltage	V _{COU1}	V _{CTL} = 0V	3.90	4.20	4.40	V
	V _{COU2}	V _{CTL} = 5V	0.60	0.80	1.10	V
Start/Stop Pin						
High-level input voltage range	V _{IH} (S/S)		V _{CC} -1.5		V _{CC}	V
Low-level input voltage range	V _{IL} (S/S)		0		1.5	V
Input open voltage	V _{IO} (S/S)		V _{CC} -0.5		V _{CC}	V
Hysteresis width	ΔV _{IN} (S/S)		0.35	0.50	0.65	V
High-level input current	I _{IH} (S/S)	V(S/S) = V _{CC}	-10	0	+10	μA
Low-level input current	I _{IL} (S/S)	V(S/S) = 0V	-280	-210		μA
Forward/Reverse Pin						
High-level input voltage range	V _{IH} (F/R)		V _{CC} -1.5		V _{CC}	V
Low-level input voltage range	V _{IL} (F/R)		0		1.5	V
Input open voltage	V _{IO} (F/R)		V _{CC} -0.5		V _{CC}	V
Hysteresis width	ΔV _{IN} (F/R)		0.35	0.50	0.65	V
High-level input current	I _{IH} (F/R)	V(F/R) = V _{CC}	-10	0	+10	μA
Low-level input current	I _{IL} (F/R)	V(F/R) = 0V	-280	-210		μA

Package Dimensions

unit : mm (typ)

3147C

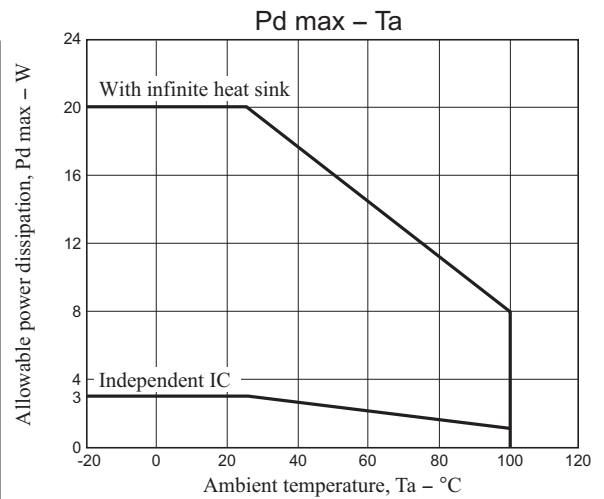
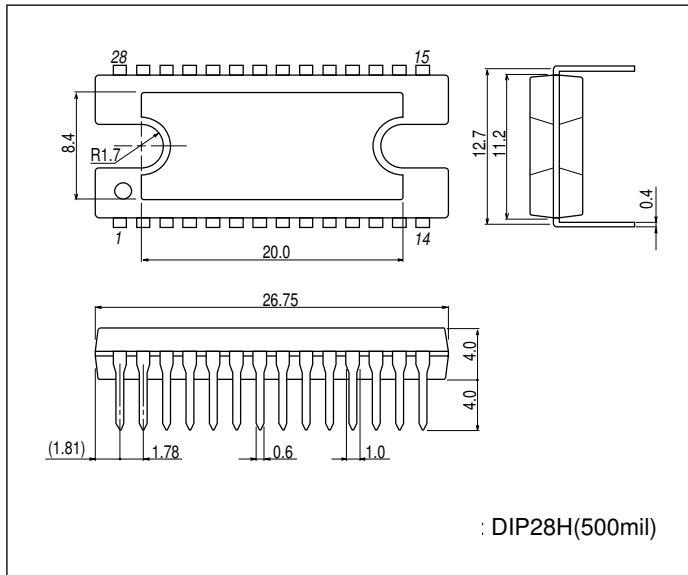

LB1976

Pin Assignment

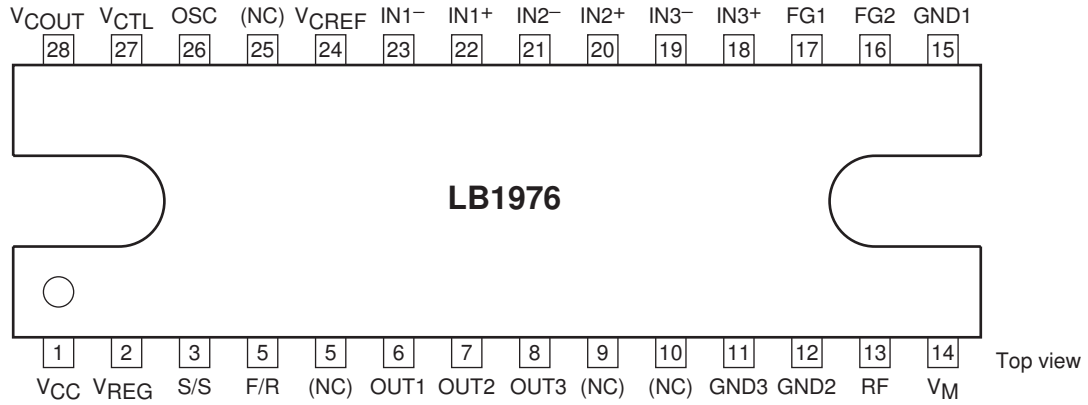

Truth Table

	Input			Forward/reverse control	Output	FG output	
	IN1	IN2	IN3	F/R	Source → Sink	FG1	FG2
1	H	L	H	L	OUT2 → OUT1	L	L
				H	OUT1 → OUT2		
2	H	L	L	L	OUT3 → OUT1	L	H
				H	OUT1 → OUT3		
3	H	H	L	L	OUT3 → OUT2	L	L
				H	OUT2 → OUT3		
4	L	H	L	L	OUT1 → OUT2	H	H
				H	OUT2 → OUT1		
5	L	H	H	L	OUT1 → OUT3	H	L
				H	OUT3 → OUT1		
6	L	L	H	L	OUT2 → OUT3	H	H
				H	OUT3 → OUT2		

F/R

Forward rotation Low
Reverse rotation High

0V to 1.5V
V_{CC} - 1.5V to V_{CC}

FG output

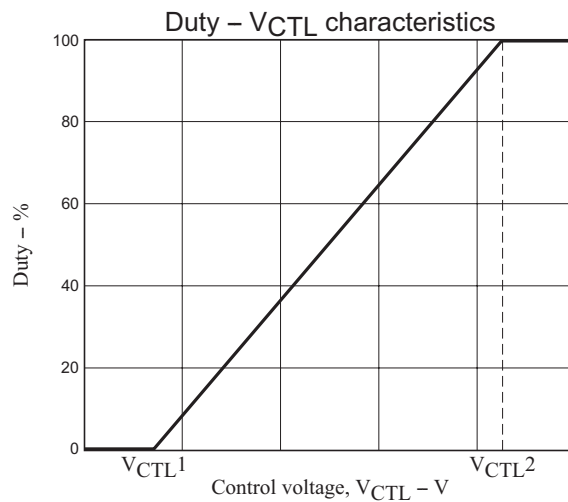
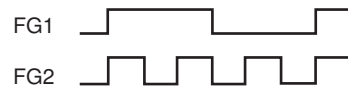

Block Diagram and Peripheral Circuit

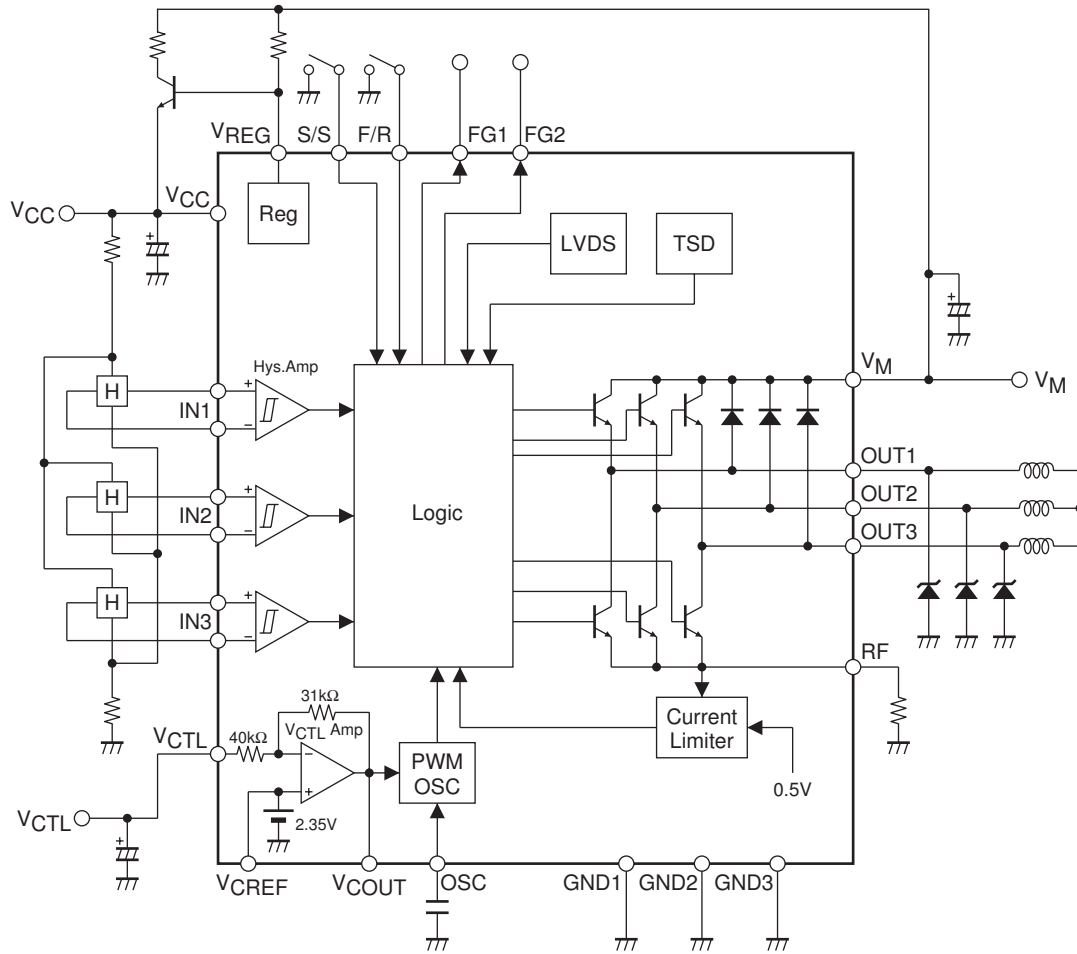

Pin Functions

Pin No.	Pin name	Pin voltage	Function	Equivalent circuit
1	V _{CC}	4.5V to 6.7V	Power supply for blocks other than the output block.	
2	V _{REG}	0.0V to 7.3V	Shunt regulator output pin (7V).	
3	S/S	0.0V to V _{CC}	Start/stop control pin. Low: start High or Open: stop Typical threshold voltage for V _{CC} = 5V: approx. 2.8V (low to high) approx. 2.3V (high to low)	

Continued on next page.

LB1976

Continued from preceding page.

Pin No.	Pin name	Pin voltage	Function	Equivalent circuit
4	F/R	0.0V to V_{CC}	Forward/reverse pin. Low: forward High or Open: reverse Typical threshold voltage for $V_{CC} = 5V$: approx. 2.8V (low to high) approx. 2.3V (high to low)	
6 7 8	OUT1 OUT2 OUT3		Output pin 1. Output pin 2. Output pin 3.	
13	RF	0.0V to V_{CC}	Output current detect pin. Connect resistor R_f between this pin and ground. Output current is limited to value set with V_{RF}/R_f . (Current limiter operation)	
14	V_M		Output block power supply.	
11	GND3		Output block ground.	
15 12	GND1 GND2		Ground for blocks other than the output block.	
17	FG1	0.0V to V_{CC}	Speed pulse output pin 1 with built-in pull-up resistor.	
16	FG2	0.0V to V_{CC}	Speed pulse output pin 2 with built-in pull-up resistor.	
22 23 20 21 18 19	IN1+ IN1- IN2+ IN2- IN3+ IN3-	1.5V to $V_{CC} - 1.5V$	Hall input pin. $IN^+ > IN^-$: High input $IN^+ < IN^-$: Low input	
26	OSC	1.0V to V_{CC}	This pin sets the PWM oscillation frequency. Connect a capacitor between this pin and ground.	

Continued on next page.

LB1976

Continued from preceding page.

Pin No.	Pin name	Pin voltage	Function	Equivalent circuit
27	V _{CTL}	0.0V to 6.7V	Output duty cycle control pin. <ul style="list-style-type: none"> • V_{CTL} ≤ V_{CTL1} Duty cycle 0% • V_{CTL1} < V_{CTL} < V_{CTL2} Duty cycle is controlled by V_{CTL} • V_{CTL} ≥ V_{CTL2} Duty cycle 100% 	
24	V _{CREF}	0.0V to V _{CC} - 2.0V	V _{CTL} amplifier internal reference voltage pin (2.35V).	
28	V _{COU}	0.7V to V _{CC} - 0.7V	V _{CTL} amplifier output pin.	

IC Description

1. Direct PWM Drive

The LB1976 employs the direct PWM drive principle. Motor rotation speed is controlled by varying the output duty cycle according to an analog voltage input (V_{CTL}). This eliminates the need to alter the motor power supply voltage. Compared to previous ICs using the PAM principle (such as the LB1690), this allows simplification of the power supply circuitry. The V_{CTL} input can be directly supplied by a microcontroller, motor speed can, therefore, be controlled directly from the microcontroller.

For PWM, the source-side output transistors are switched on and off so that the ON duty tracks the V_{CTL} input. The output duty cycle can be controlled over the range of 0% to 100% by the V_{CTL} input.

2. PWM Frequency

The PWM oscillator frequency f_{PWM} [Hz] is set by the capacitance C [pF] connected between the OSC pin and GND. The following equation applies:

$$f_{PWM} \approx 1 / (1.97 \times C) \times 10^8$$

Because output transistor on/off switching is subject to a delay, setting the PWM frequency to a very high value will cause the delay to become noticeable. The PWM frequency therefore should normally be kept below 40kHz (typ.), which is achieved with a capacitance C of 1300pF or higher. For reference, the source-side output transistor switching delay time is about 2 μ s for ON and about 4 μ s for OFF.

3. Output Diodes

Because the PWM switching operation is carried out by the source-side output transistors, Schottky barrier diodes must be connected between the OUT pins and GND (OUT1 to OUT3). Use diodes with an average forward current rating in the range of 1.0 to 2.0A, in accordance with the motor type and current limiting requirements.

If no Schottky barrier diodes are connected externally, or if Schottky barrier diodes with high forward voltage (V_F) are used, the internal parasitic diode between OUT and GND becomes active. When this happens, the output logic circuit may malfunction, resulting in feed-through current in the output which can destroy the output transistors. To prevent this possibility, Schottky barrier diodes must be used and dimensioned properly.

The larger the V_F of the externally connected Schottky barrier diodes, or the hotter the IC is, the more likely are the parasitic diodes between OUT and GND to become active and the more likely is malfunction to occur. The V_F of the Schottky barrier diodes must be determined so that output malfunction does not occur also when the IC becomes hot. If malfunction occurs, choose a Schottky barrier diode with lower V_F .

4. Protection circuits

4-1. Low voltage protection circuit

When the V_{CC} voltage falls below a stipulated level (V_{LVSD}), the low voltage protection circuit cuts off the source-side output transistors to prevent V_{CC} related malfunction.

4-2. Thermal shutdown circuit (overheat protection circuit)

When the junction temperature rises above a stipulated value (TSD), the thermal shutdown circuit cuts off the sourceside output transistors to prevent IC damage due to overheating. Design the application heat characteristics so that the protection circuit will not be triggered under normal circumstances.

4-3. Current limiter

The current limiter cuts off the source-side output transistors when the output current reaches a preset value (limiter value). This interrupts the source current and thereby limits the output current peak value. By connecting the resistance R_f between the RF pin and ground, the output current can be detected as a voltage. When the RF pin voltage reaches 0.5V (typ.), the current limiter is activated. It performs on/off control of the source-side output transistors, thereby limiting the output current to the value determined by $0.5/R_f$.

5. Hall Input Circuit

The Hall input circuit is a differential amplifier with a hysteresis of 32mV (typ.). The operation DC level must be within the common-mode input voltage range (1.5V to $V_{CC} - 1.5V$). To prevent noise and other adverse influences, the input level should be at least 3 times the hysteresis (120 to 16mVp-p). If noise at the Hall input is a problem, a noise-canceling capacitor (about 0.01 μ F) should be connected across the Hall input IN^+ and IN^- pins.

6. FG Output Circuit

The Hall input signal at $IN1$, $IN2$, and $IN3$ is combined and subject to waveform shaping before being output. The signal at FG1 has the same frequency as the FG1 Hall input, and the signal at FG2 has a frequency that is three times higher.

7. Start/Stop Control Circuit

The start/stop control circuit turns the source-side output transistors OFF (motor stop) when a High signal is input at the S/S pin or when the pin is Open. When a Low signal is input at the S/S pin, the source-side output transistors are turned ON, and the normal operation state is established (motor start).

8. Forward/Reverse Switching

The LB1976 is designed under the assumption that forward/reverse switching is not carried out while the motor is running. If switching is carried out while the motor is running, reverse torque braking occurs, leading to a high current flow. If the current limiter is triggered, the source-side output transistors are switched off, and the sink-side output transistors go into the short brake condition. However, because the current limiter of this IC cannot control the current flowing in the sink-side output transistors, these may be destroyed by the short brake current. Therefore F/R switching while the motor is running is permissible only if the output current (I_O) is limited to a maximum of 2.5A using the motor coil resistance or other suitable means.

F/R switching should be carried out only while a High signal is input to the S/S pin or the pin is Open (stop condition), or while the VCTL pin conforms to the following condition: $V_{CTL} \leq V_{CTL1}$ (duty cycle 0%). In any other condition, F/R switching will result in feed-through current. The F/R pin should therefore be fixed to Low (forward) or High or Open (reverse) during use.

9. VCC, VM Power Supplies

When the power supply voltage (V_{CC} , V_M) rises very quickly when a power is first applied, a feed-through current may occur at the output. If the current remains below about 0.2A to 0.3A, it does not pose a problem, but such a possibility should still be prevented by slowing down the voltage rise at power-on. Especially if the F/R pin is set to High or Open (reverse), a quick rise in V_{CC} is likely to cause feed-through current. This should be prevented by ensuring that $\Delta V_{CC} / \Delta t = 0.2V/\mu s$ or less. Feed-through current can also be prevented by first switching on V_{CC} and then V_M during power-on.

The sequence at power-down should be as follows. Provide a stop input to the S/S pin or a duty ratio 0% input to the VCTL pin. When the motor has come to a full stop, switch off V_M and then V_{CC} . If power is switched off while the motor is still rotating or a current is flowing in the motor coil (including motor restraint or inertia rotation), a counter electromotive current or kickback current may flow on the V_M side, depending on the motor type and power-off procedure. If this current cannot be absorbed by the V_M power supply or a capacitor, V_M voltage may rise and exceed the absolute maximum V_M rating for the IC. Ensure that this does not happen through proper design of the V_M power supply or through use of a capacitor.

Because the LB1976 incorporates a shunt regulator, it can be used on a single power supply. In this case, supply V_{CC} (6.3V typ.) to the VREG pin via an external NPN transistor and resistor. When not using the regulator, leave the VREG pin open.

10. Power Supply Stabilizing Capacitors

If the V_{CC} line fluctuates drastically, the low-voltage protection circuit may be activated by mistake, or other malfunctions may occur. The V_{CC} line must therefore be stabilized by connecting a capacitor of at least several μF between V_{CC} and GND. Because a large switching current flows in the V_M line, wiring inductance and other factors can lead to V_M voltage fluctuations. As the GND line also fluctuates, the V_M line must be stabilized by connecting a capacitor of at least several μF between V_M and GND, to prevent exceeding V_M max or other problems. Especially when long wiring runs (V_M , V_{CC} , GND) are used, sufficient capacitance should be provided to ensure power supply stability.

11. VCREF Pin, VCOOUT Pin

These pins are always used in the Open condition. If chattering occurs in the PWM switching output, connect a capacitor (about 0.1 μF) between VCREF and ground or between VCOOUT and GND.

12. IC Heat Dissipation Fins

A heat sink may be mounted to the heat dissipation fins of this IC, but it may not be connected to GND. The sink should be electrically open.

13. Sample calculation for internal power dissipation (approximate)

The calculation assumes the following parameters:

$$V_{CC} = 5V$$

$$V_M = 30V$$

Source-side output transistor ON duty cycle 80% (PWM control)

Output current $I_O = 1A$ (RF pin average current)

(1) I_{CC} power dissipation P1

$$P1 = V_{CC} \times I_{CC} = 5V \times 14mA = 0.07W$$

(2) Output drive current power dissipation P2

$$P2 = V_M \times I_O = 30V \times 11mA = 0.33W$$

(3) Source-side output transistor power dissipation P3

$$P3 = V_O(\text{source}) \times I_O \times \text{Duty}(\text{on}) = 0.9V \times 1A \times 0.8 = 0.72W$$

(4) Sink-side output transistor power dissipation P4

$$P4 = V_O(\text{sink}) \times I_O = 1.1V \times 1A = 1.10W$$

(5) Total internal power dissipation P

$$P = P1 + P2 + P3 + P4 = 2.22W$$

14. IC temperature Rise Measurement

Because the chip temperature of the IC cannot be measured directly, measurement according to one of the following procedures should always be carried out.

14-1. Thermocouple measurement

A thermocouple element is mounted to the IC heat dissipation fin. This measurement method is easy to implement, but it will be subject to measurement errors if the temperature is not stable.

14-2. Measurement using internal diode characteristics of IC

This is the recommended measurement method. It makes use of the parasitic diode incorporated in the IC between FG1 and GND. Set FG1 to High and measure the voltage V_F of the parasitic diode to calculate the temperature.

(Our company data: for $I_F = -1mA$, V_F temperature characteristics are about $-2mV/^\circ C$)

15. NC Pins

Because NC pins are electrically open, they may be used for wiring purpose etc.

ON Semiconductor and the ON logo are registered trademarks of Semiconductor Components Industries, LLC (SCILLC). SCILLC owns the rights to a number of patents, trademarks, copyrights, trade secrets, and other intellectual property. A listing of SCILLC's product/patent coverage may be accessed at www.onsemi.com/site/pdf/Patent-Marking.pdf. SCILLC reserves the right to make changes without further notice to any products herein. SCILLC makes no warranty, representation or guarantee regarding the suitability of its products for any particular purpose, nor does SCILLC assume any liability arising out of the application or use of any product or circuit, and specifically disclaims any and all liability, including without limitation special, consequential or incidental damages. "Typical" parameters which may be provided in SCILLC data sheets and/or specifications can and do vary in different applications and actual performance may vary over time. All operating parameters, including "Typicals" must be validated for each customer application by customer's technical experts. SCILLC does not convey any license under its patent rights nor the rights of others. SCILLC products are not designed, intended, or authorized for use as components in systems intended for surgical implant into the body, or other applications intended to support or sustain life, or for any other application in which the failure of the SCILLC product could create a situation where personal injury or death may occur. Should Buyer purchase or use SCILLC products for any such unintended or unauthorized application, Buyer shall indemnify and hold SCILLC and its officers, employees, subsidiaries, affiliates, and distributors harmless against all claims, costs, damages, and expenses, and reasonable attorney fees arising out of, directly or indirectly, any claim of personal injury or death associated with such unintended or unauthorized use, even if such claim alleges that SCILLC was negligent regarding the design or manufacture of the part. SCILLC is an Equal Opportunity/Affirmative Action Employer. This literature is subject to all applicable copyright laws and is not for resale in any manner.