



ON Semiconductor®

<http://onsemi.com>

LB11867RV

Monolithic Digital IC

For Fan Motor

Variable Speed Single-phase Full-wave Pre-driver

Overview

LB11867RV is a single-phase bipolar driving motor pre-driver with the variable speed function compatible with external PWM signal. With a few external parts, a highly-efficient and highly-silent variable drive fan motor with low power consumption can be achieved. This product is best suited for driving of the server requiring large air flow and large current and the fan motor of consumer appliances.

Features

- Single-phase full-wave driving pre-driver
 - ⇒ Low-saturation drive using external PMOS-NMOS enables high-efficiency low power-consumption drive.
- Variable speed control possible with external PWM input
 - ⇒ Separately-excited upper direct PWM ($f=30\text{kHz}$) control method ensures highly silent speed control.
- Current limiting circuit incorporated
 - ⇒ Chopper type current limiting made at startup and during lock.
- Reactive current cut circuit incorporated
 - ⇒ Reactive current before phase changeover is cut, ensuring highly silent and low power-consumption drive.
- Minimum speed setting pin
 - ⇒ Minimum speed can be set by setting the resistance.
- Soft start setting pin
- Lock protection and automatic reset circuits incorporated
- RD (lock detection) output
- Thermal shutdown circuit incorporated

LB11867RV

Specifications

Absolute Maximum Ratings at Ta = 25°C

Parameter	Symbol	Conditions	Ratings	Unit
V _{CC} pin maximum supply voltage	V _{CC} max		18	V
OUTN pin maximum output current	I _{OUTN} max		20	mA
OUTP pin maximum Sink current	I _{OUTP} max		20	mA
OUT pin output withstand voltage	V _{OUT} max		18	V
V _{TH} , RMI pins withstand voltage	V _{VTH} , V _{VRMI} max		7	V
S-S pin withstand voltage	V _{S-S} max		7	V
RD output pin withstand voltage	V _{RD} max		19	V
RD pin maximum output current	I _{RD} max		10	mA
5VREG pin maximum output current	I _{5VREG} max		20	mA
Allowable power dissipation	P _d max	with specified substrate *1	800	mW
Operating temperature	T _{opr}	*2	-30 to 90	°C
Storage temperature	T _{stg}		-55 to 150	°C

*1 Specified substrate: 114.3mm×76.1mm×1.6mm, glass epoxy board.

*2 T_j max=150°C must not be exceeded.

Stresses exceeding Maximum Ratings may damage the device. Maximum Ratings are stress ratings only. Functional operation above the Recommended Operating Conditions is not implied. Extended exposure to stresses above the Recommended Operating Conditions may affect device reliability.

Recommended Operating Conditions at Ta = 25°C

Parameter	Symbol	Conditions	Ratings	Unit
V _{CC} Supply voltage	V _{CC}		5.5 to 16	V
V _{TH} , RMI input voltage range	V _{TH} , RMI		0 to 5	V
Hall input common-phase input voltage range	V _{ICM}		0.2 to 3	V

Electrical Characteristics at Ta = 25°C, V_{CC} = 12V

Parameter	Symbol	Conditions	Ratings			Unit
			min	typ	max	
Circuit current	I _{CC1}	During drive	5.5	7.5	9.5	mA
	I _{CC2}	During lock protection	5.5	7.5	9.5	mA
5VREG voltage	5VREG	I _{5VREG} = 5mA	4.80	4.95	5.10	V
Current limiting voltage	V _{LIM}		185	200	215	mV
CPWM pin "H" level voltage	V _{CPWMH}		2.8	3.0	3.2	V
CPWM pin "L" level voltage	V _{CPWML}		0.9	1.1	1.3	V
CPWM pin charge current	I _{CPWM1}	V _{CPWM} = 0.5V	24	30	36	μA
CPWM pin discharge current	I _{CPWM2}	V _{CPWM} = 3.5V	21	27	33	μA
CPWM Oscillation frequency	FPWM	C = 220PF		30		kHz
CT pin "H" level voltage	V _{CTH}		2.8	3.0	3.2	V
CT pin "L" level voltage	V _{CTL}		0.9	1.1	1.3	V
CT pin charge current	I _{CT1}	V _{CT} = 0.5V	1.6	2.0	2.5	μA
CT pin discharge current	I _{CT2}	V _{CT} = 3.5V	0.16	0.20	0.25	μA
CT pin charge/discharge ratio	R _{CT}	I _{CT1} /I _{CT2}	8	10	12	times
S-S pin discharge current	I _{S-S}	V _{S-S} = 1V	0.4	0.5	0.6	μA
OUTN output H-level voltage	V _{ONH}	I _O = 10mA		V _{CC} -0.85	V _{CC} -1.00	V
OUTN output L-level voltage	V _{ONL}	I _O = 10mA		0.9	1.00	V
OUTP output L-level voltage	V _{OPL}	I _O = 10mA		0.5	0.65	V
Hall input sensitivity	V _{HN}	I _{N+} , I _{N-} differential voltage (including offset and hysteresis)		±10	±20	mV
RD output L-level voltage	V _{RD} L	I _{RD} = 5mA		0.15	0.30	V
RD pin leakage current	I _{RD} L	V _{RD} = 19V			20	μA
V _{TH} /RMI pin bias current	I _{VTH} /I _{RMI}	CPWM = V _{TH} /RMI = 2V			0.1	μA

Package Dimensions

unit : mm (typ)
3178B

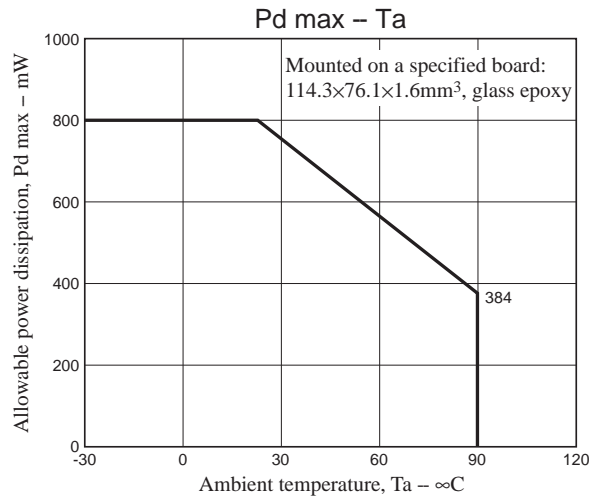
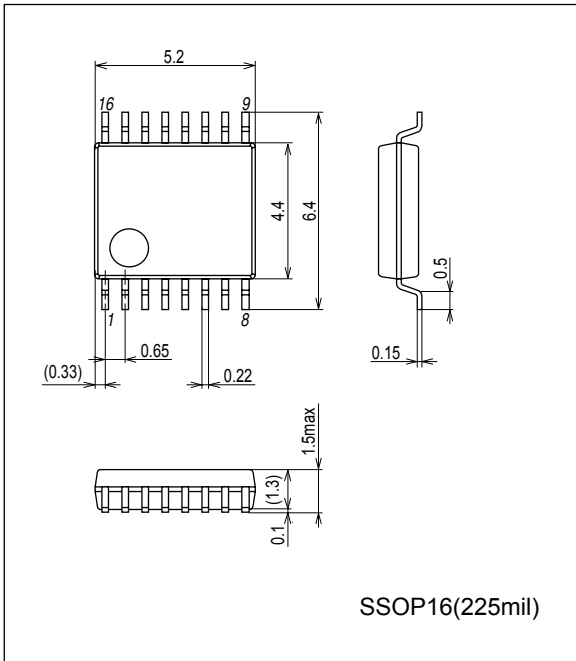

Pin Assignment

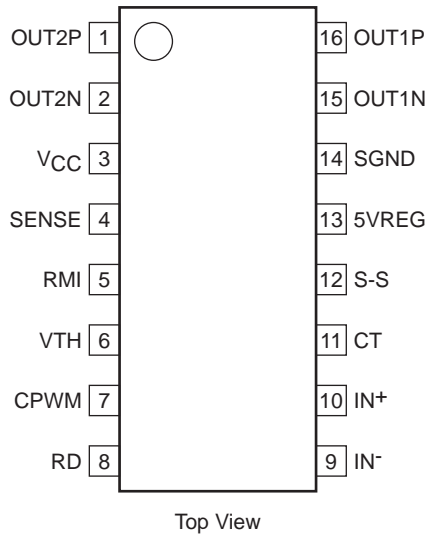

Block Diagram

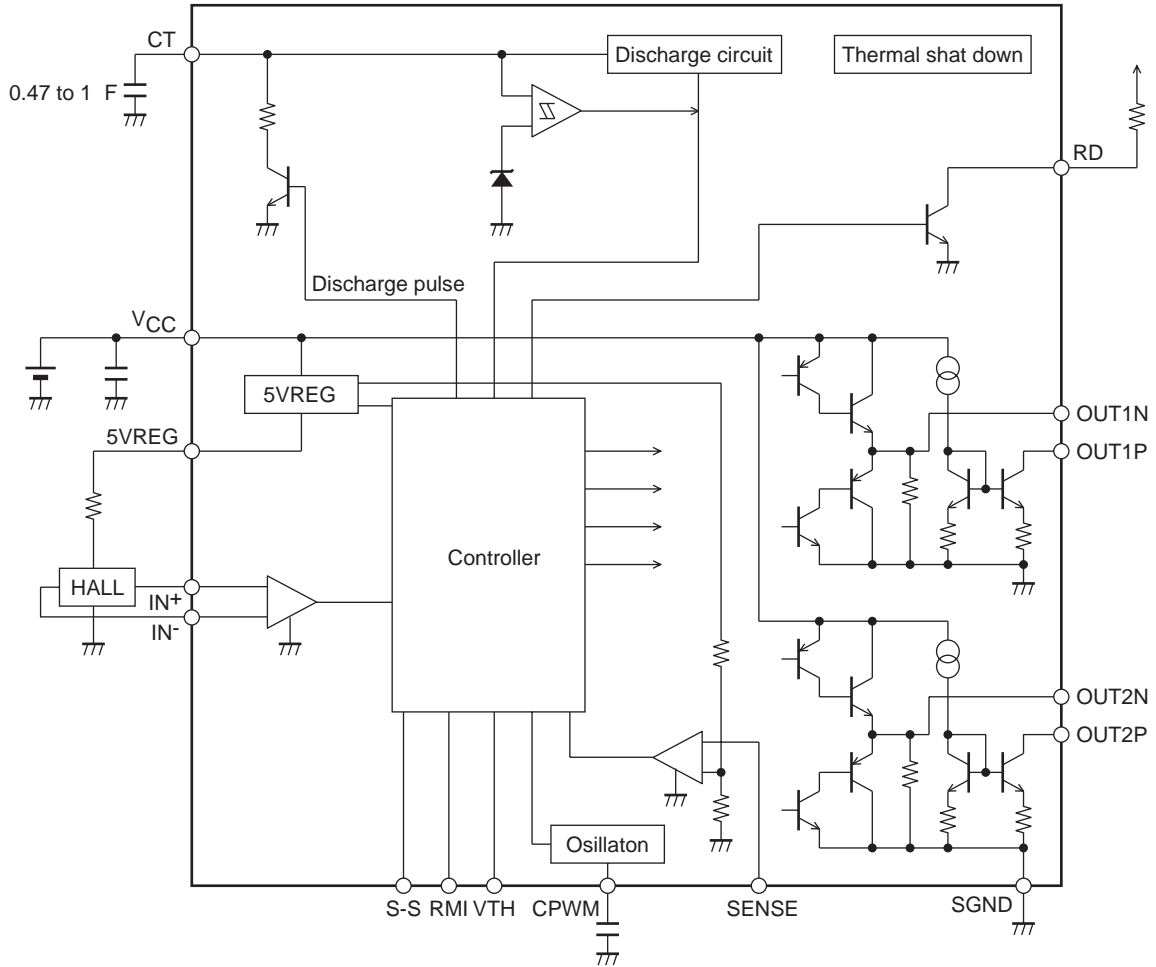

Truth table

(1) Drive lock CPWM=H VTH, RMI, S-S=L

IN ⁻	IN ⁺	CT	OUT1P	OUT1N	OUT2P	OUT2N	RD	Mode
H	L	L	L	L	OFF	H	L	OUT1 → 2 drive
L	H		OFF	H	L	L	L	OUT2 → 1 drive
H	L	H	OFF	L	OFF	H	OFF	Lock protection
L	H		OFF	H	OFF	L	OFF	

(2) Speed control CT, S-S=L

VTH, RMI	CPWM	IN ⁻	IN ⁺	OUT1P	OUT1N	OUT2P	OUT2N	Mode
L	H	H	L	L	L	OFF	H	OUT1 → 2 drive
		L	H	OFF	H	L	L	OUT2 → 1 drive
H	L	H	L	OFF	L	OFF	H	Regeneration mode
		L	H	OFF	H	OFF	L	

For VTH, RMI, and S-S pins, refer to the timing chart.

Application Circuit Example (12V)

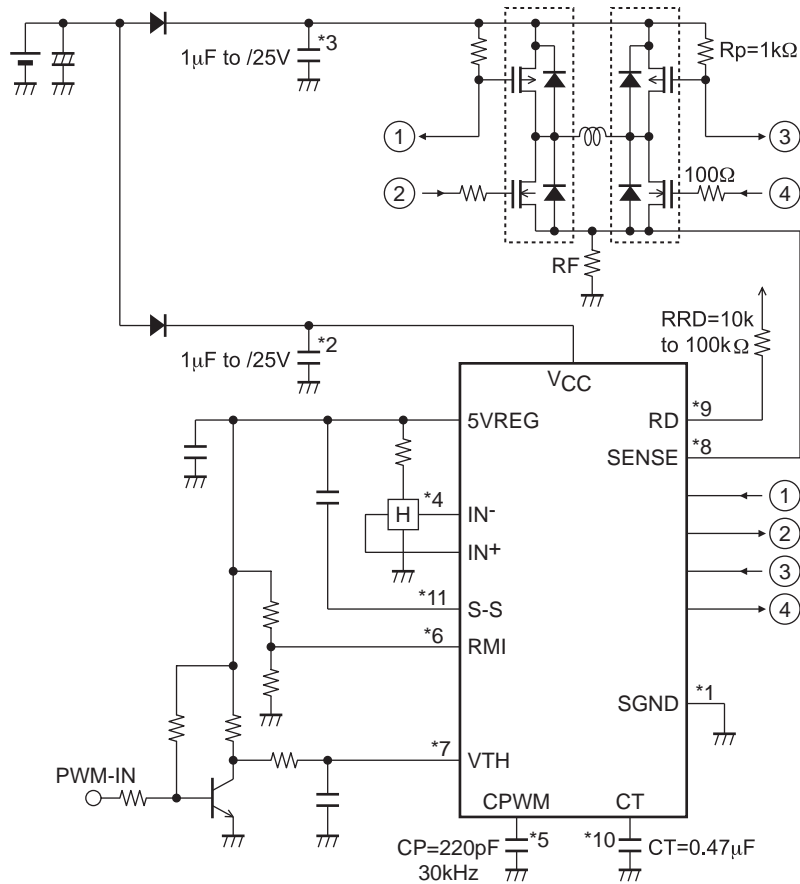

*1. Power-GND wiring

SGND is connected to the control circuit power supply system.

*2. Power stabilization capacitor

For the power stabilization capacitor on the signal side, use the capacitance of 1μF or more. Connect VCC and GND with a thick and shortest pattern.

*3. Power stabilization capacitor on the power side

For the power stabilization capacitor on the power side, use the capacitance of 1μF or more. Connect the power supply on the power side and GND with a thick and shortest pattern.

*4. IN⁺, IN⁻ pins

Hall signal input pin.

Wiring should be short to prevent carrying of noise.

If noise is carried, insert the capacitor between IN⁺ and IN⁻ pins.

The Hall input circuit functions as a comparator with hysteresis (15mV).

This also has a soft switch section with ±30mV (input signal differential voltage).

It is also recommended that the Hall input level is minimum 100mV(p-p).

*5. CPWM pin

Pin to connect the capacitor for generation of the PWM basic frequency

The use of CP = 220pF causes oscillation at f = 30kHz, which is the basic frequency of PWM.

As this is used also for the current limiting canceling signal, be sure to connect the capacitor even when the speed control is not made.

*6. RMI pin

Minimum speed setting pin.

Perform pull-up with 5VREG when this pin is not to be used.

If the IC power supply is likely to be turned OFF first when the pin is used with external power supply, be sure to insert the current limiting resistor to prevent inflow of large current. (The same applies to the VTH pin.)

*7. VTH pin

Speed control pin.

Connect this pin to GND when it is not used (at full speed).

For the control method, refer to the timing chart.

For control with pulse input, insert the current limiting resistor and use the pin with the frequency of 20k to 100kHz (20kHz to 50kHz recommended).

*8. SENSE pin

Current limiting detection pin.

When the pin voltage exceeds 0.2V, the current is limited and the operation enters the lower regeneration mode.

Connect this pin to GND when it is not to be used.

*9. RD pin

Lock detection pin

In open collector output, L upon rotation and H when locked (using pull-up resistance).

Keep this pin open when it is not to be used.

*10. CT pin

Pin to connect the lock detection capacitor.

The constant-current charge and discharge circuits incorporated cause locking when the pin voltage becomes 3.0V and unlocking when it is 1.1V.

Connect the pin to GND when it is not to be used (locking not necessary).

*11. S-S pin

Pin to connect the soft-start setting capacitor.

Connect the capacitor between 5VREG and S-S pin.

This pin enables setting of the soft start time according to the capacity of the capacitor.

See the timing char.

Connect the pin to GND when it is not to be used.

Control timing chart (Speed control)

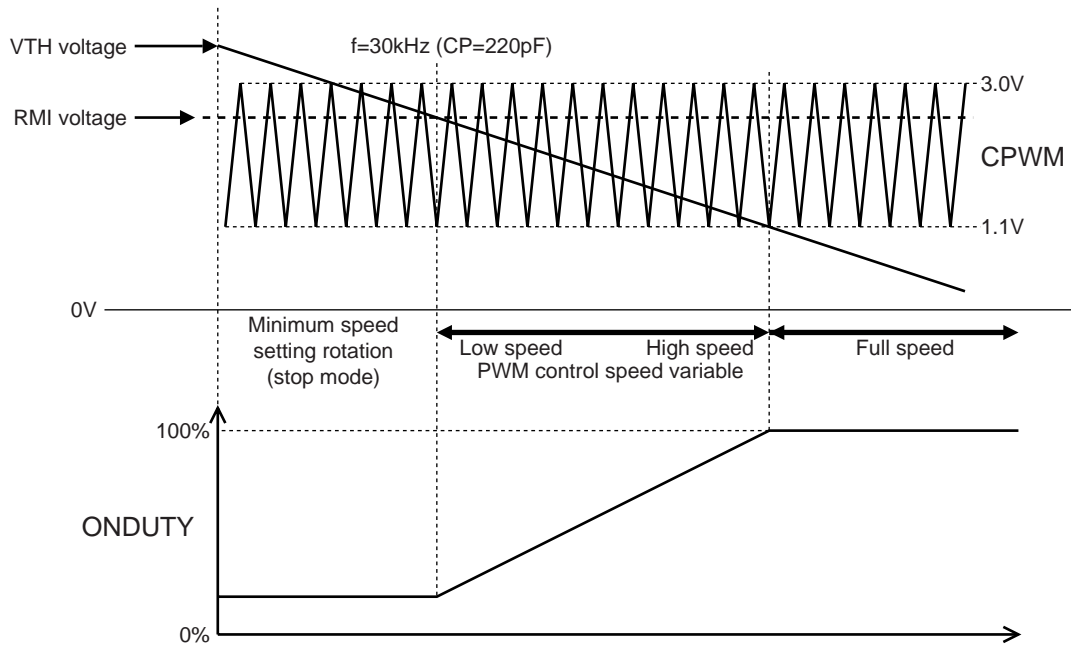

(1) Minimum speed setting (stop) mode

The low-speed fan rotation occurs at the minimum speed set with the RMI pin. When the minimum speed is not set (RMI pin pulled up to 5VREG), the motor stops.

(2) Low speed \leftrightarrow high speed

PMW control is made by comparing the CPWM oscillation voltage (1.1V \leftrightarrow 3.0V) and VTH voltage. Both upper and lower output TRs are turned ON when the VTH voltage is low. The upper output TR is turned OFF when the VTH voltage is high, regenerating the coil current in the lower TR. Therefore, as the VTH voltage decreases, the output ON-DUTY increases, causing increase in the coil current, raising the motor rotation speed.

(3) Full speed mode

The full speed mode becomes effective when the VTH voltage is 1.1V or less. (Set VTH = GND when the speed control is not to be made.)

Control timing chart (Soft start)

(1) At $V_{TH} < RMI$ voltage

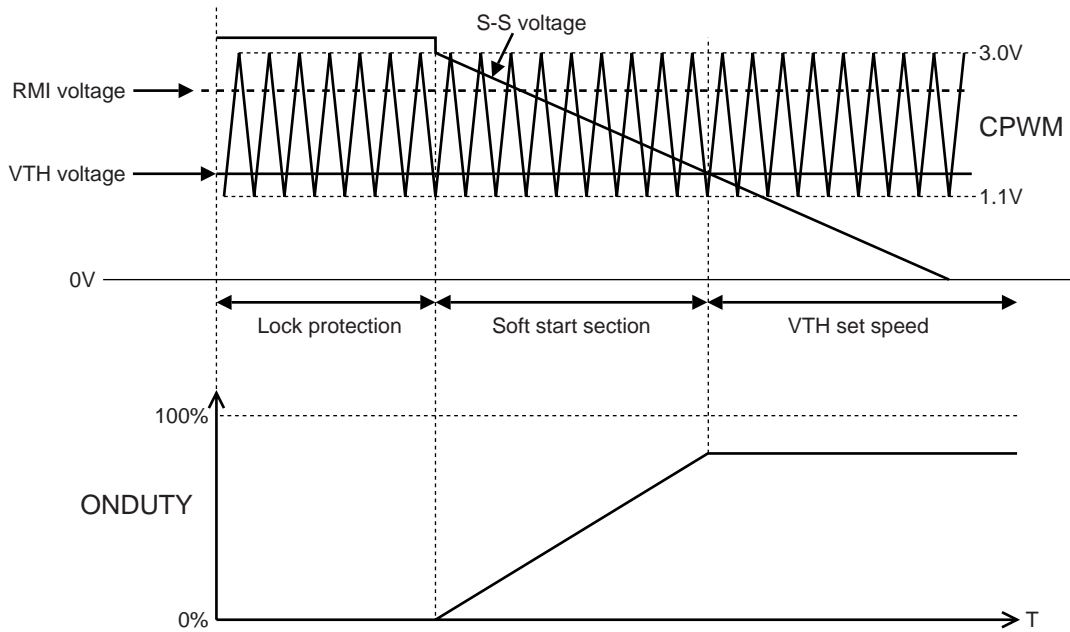

(2) At $V_{TH} > RMI$ voltage

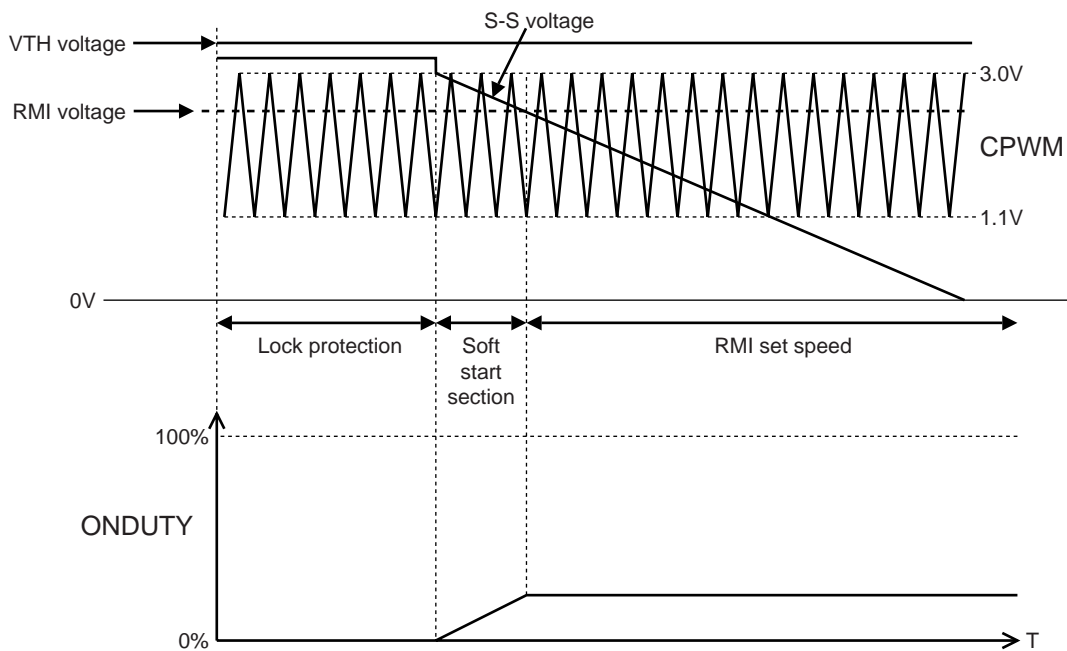

Adjust the S-S pin voltage gradient by means of the capacitance of the capacitor between the S-S pin and 5VREG.
 Recommended capacitor: 0.1 μ F to 1 μ F

ON Semiconductor and the ON logo are registered trademarks of Semiconductor Components Industries, LLC (SCILLC). SCILLC owns the rights to a number of patents, trademarks, copyrights, trade secrets, and other intellectual property. A listing of SCILLC's product/patent coverage may be accessed at www.onsemi.com/site/pdf/Patent-Marking.pdf. SCILLC reserves the right to make changes without further notice to any products herein. SCILLC makes no warranty, representation or guarantee regarding the suitability of its products for any particular purpose, nor does SCILLC assume any liability arising out of the application or use of any product or circuit, and specifically disclaims any and all liability, including without limitation special, consequential or incidental damages. "Typical" parameters which may be provided in SCILLC data sheets and/or specifications can and do vary in different applications and actual performance may vary over time. All operating parameters, including "Typicals" must be validated for each customer application by customer's technical experts. SCILLC does not convey any license under its patent rights nor the rights of others. SCILLC products are not designed, intended, or authorized for use as components in systems intended for surgical implant into the body, or other applications intended to support or sustain life, or for any other application in which the failure of the SCILLC product could create a situation where personal injury or death may occur. Should Buyer purchase or use SCILLC products for any such unintended or unauthorized application, Buyer shall indemnify and hold SCILLC and its officers, employees, subsidiaries, affiliates, and distributors harmless against all claims, costs, damages, and expenses, and reasonable attorney fees arising out of, directly or indirectly, any claim of personal injury or death associated with such unintended or unauthorized use, even if such claim alleges that SCILLC was negligent regarding the design or manufacture of the part. SCILLC is an Equal Opportunity/Affirmative Action Employer. This literature is subject to all applicable copyright laws and is not for resale in any manner.