



LA5771

— Monolithic Linear IC
Separately-excited Step-down
Switching Regulator (3.3V)

Overview

The LA5771 is a separately-excited step-down switching regulator (3.3V).

Features

- High efficiency
- Four external parts
- Time-base generator (160kHz) incorporated
- Current limiter incorporated
- Thermal shutdown circuit incorporated
- Soft start circuit incorporated

Specifications

Absolute Maximum Ratings at $T_a = 25^\circ\text{C}$

Parameter	Symbol	Conditions	Ratings	Unit
Input voltage	$V_{IN\ max}$		34	V
Output current	$I_O\ max$		3	A
SW pin application reverse voltage	V_{sw}		-1	V
Allowable power dissipation	$P_d\ max1$	No heat sink	1.75	W
	$P_d\ max2$	Infinite heat sink	7.5	W
Operating temperature	T_{opr}		-30 to +125	$^\circ\text{C}$
Storage temperature	T_{stg}		-40 to +150	$^\circ\text{C}$

Recommended Operating Conditions at $T_a = 25^\circ\text{C}$

Parameter	Symbol	Conditions	Ratings	Unit
Input voltage range	V_{IN}		5.5 to 32	V

■ Any and all SANYO Semiconductor Co.,Ltd. products described or contained herein are, with regard to "standard application", intended for the use as general electronics equipment (home appliances, AV equipment, communication device, office equipment, industrial equipment etc.). The products mentioned herein shall not be intended for use for any "special application" (medical equipment whose purpose is to sustain life, aerospace instrument, nuclear control device, burning appliances, transportation machine, traffic signal system, safety equipment etc.) that shall require extremely high level of reliability and can directly threaten human lives in case of failure or malfunction of the product or may cause harm to human bodies, nor shall they grant any guarantee thereof. If you should intend to use our products for applications outside the standard applications of our customer who is considering such use and/or outside the scope of our intended standard applications, please consult with us prior to the intended use. If there is no consultation or inquiry before the intended use, our customer shall be solely responsible for the use.

■ Specifications of any and all SANYO Semiconductor Co.,Ltd. products described or contained herein stipulate the performance, characteristics, and functions of the described products in the independent state, and are not guarantees of the performance, characteristics, and functions of the described products as mounted in the customer's products or equipment. To verify symptoms and states that cannot be evaluated in an independent device, the customer should always evaluate and test devices mounted in the customer's products or equipment.

LA5771

Electrical Characteristics at Ta = 25°C

Parameter	Symbol	Conditions	Ratings			Unit
			min	typ	max	
Output voltage	V_O	$V_{IN}=15V, I_O=1.0A$	3.17	3.30	3.43	V
Efficiency	η	$V_{IN}=15V, I_O=1.0A$		79		%
Switching frequency	f	$V_{IN}=15V, I_O=1.0A$	120	160	200	kHz
Line regulation	ΔV_{OLINE}	$V_{IN}=8 \text{ to } 20V, I_O=1.0A$		25	80	mV
Load regulation	ΔV_{OLOAD}	$V_{IN}=15V, I_O=0.5 \text{ to } 1.5A$		10	30	mV
Output voltage temperature coefficient	$\Delta V_O/\Delta T_a$			± 0.5		mV/°C
Ripple attenuation factor	RREJ	F=100 to 120Hz		45		dB
Current limiter operating voltage	IS	$V_{IN}=15V$	3.1			A
Thermal shutdown operating temperature	TSD	Designed target value*		165		°C
Thermal shutdown hysteresis width	ΔTSD	Designed target value*		15		°C

* Designed target value: No measurement made.

Package Dimensions

unit : mm (typ)

3079C

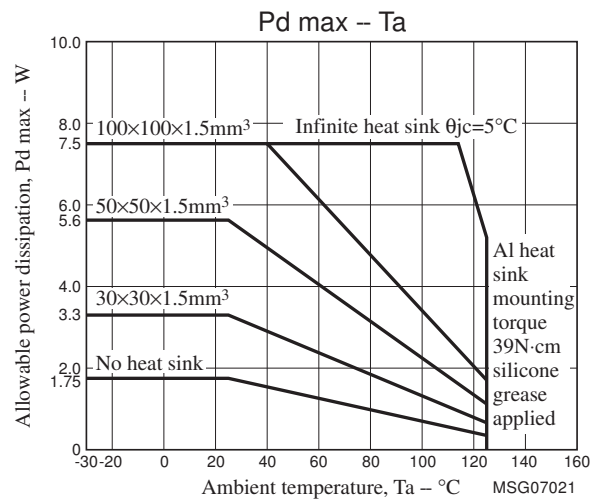
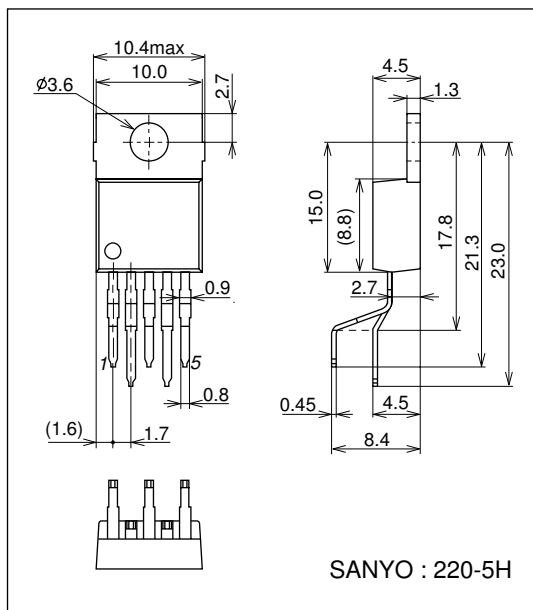

Pin Assignment

(1)VIN (2)SWOUT (3)GND (4)VOS (5)SS

LA5771

Block Diagram

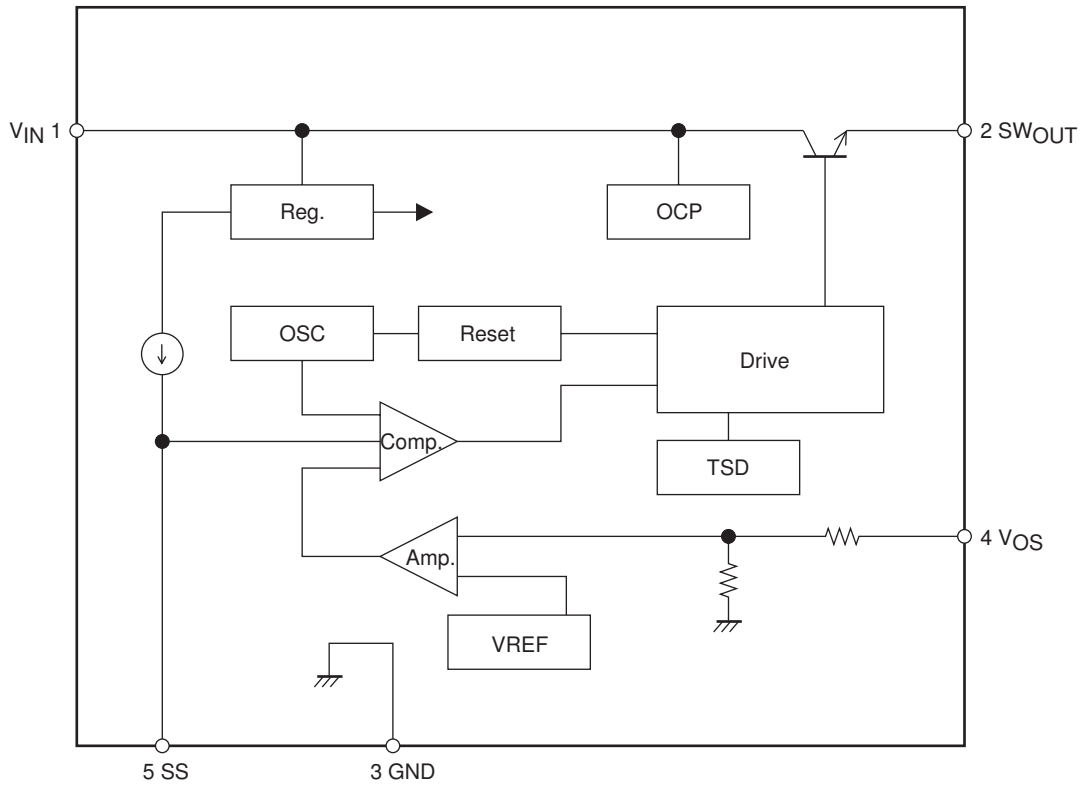

Application Circuit Example

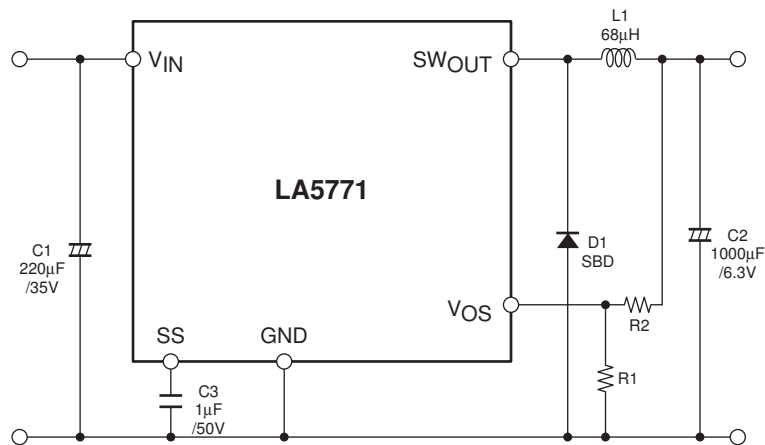

Notes: C3 is for the soft start function. Delete C3 and keep the SS pin open when the soft function is not necessary.

Description of Functional Settings

1. Start delay function

The SS pin has the internally-connected 22μA (typ) constant-current supply. When the voltage of SS pin exceeds the threshold voltage, the regulator starts operation. As the threshold is 0.62V(typ), the start delay time can be calculated as follows:

ex. For setting at 1μF

$$T_d = \frac{C \times V}{i} = \frac{1\mu \times 0.62}{22\mu} = 28.2 \text{ msec}$$

2. Soft start function

The internal PWM waveform has the voltage value as shown in the right.

If down-conversion from the voltage of $V_{IN}=15V$ to 3.3V output to be made, for example, the PWM-ON duty has the value as shown below.

$$PWMduty = \frac{V_{OUT} + V_F}{V_{IN} - V_{sat} + V_F} = 25\%$$

(Note that calculation is made with $V_{sat}=1V$ and $V_F=0.2V$)

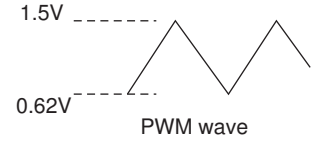

The output voltage of error amplifier, which is 3.3V, is the value with PWM=25%, as calculated in the above equation, so that this voltage is determined as follows:

$$V_{er} = (\Delta VPWM) \times PWMduty + VPWML = 0.88V \times 0.25 + 0.62V = 0.84V$$

($\Delta VPWM$ is the PWM amplitude value or 0.88V(typ) while $VPWML$ is the lower limit voltage of PWM waveform or 0.62V(typ))

SS pin and error amplifier output voltages are designed to prefer the lower voltages, so that V_{OUT} will reach the designed regulation voltage in timing when the SS pin voltage exceeds the error amplifier output. Therefore, the soft start time is calculated as follows:

$$T_{ss} = \frac{C \times \Delta VPWM \times PWMduty}{i} = \frac{C \times 0.88 \times PWMduty}{22\mu A}$$

For the set conditions of $C=1\mu F$ and $PWMduty=25\%$:

$$T_{ss} = \frac{1\mu \times 0.88V \times 0.25}{22\mu A} = 10msec$$

Timing Chart

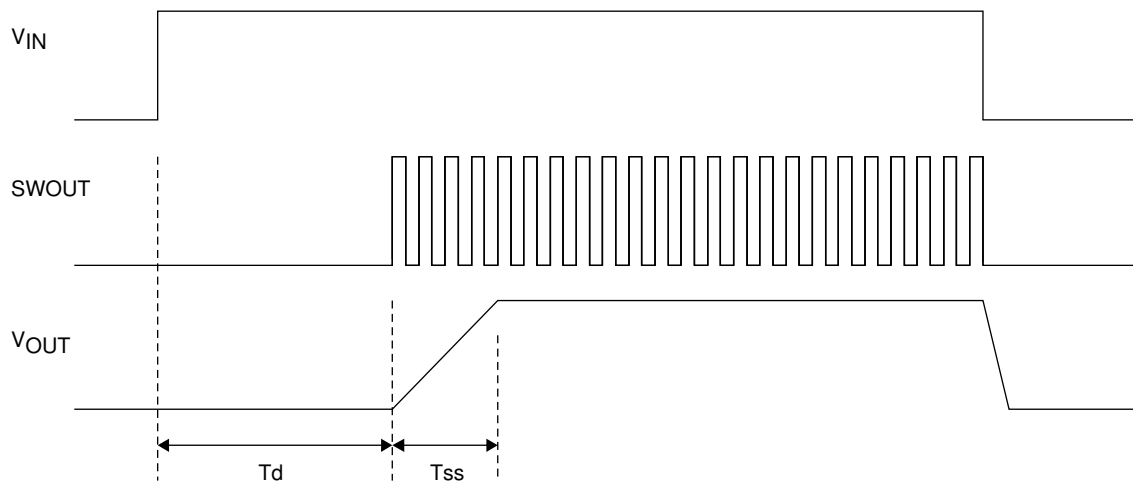

- SANYO Semiconductor Co.,Ltd. assumes no responsibility for equipment failures that result from using products at values that exceed, even momentarily, rated values (such as maximum ratings, operating condition ranges, or other parameters) listed in products specifications of any and all SANYO Semiconductor Co.,Ltd. products described or contained herein.
- SANYO Semiconductor Co.,Ltd. strives to supply high-quality high-reliability products, however, any and all semiconductor products fail or malfunction with some probability. It is possible that these probabilistic failures or malfunction could give rise to accidents or events that could endanger human lives, trouble that could give rise to smoke or fire, or accidents that could cause damage to other property. When designing equipment, adopt safety measures so that these kinds of accidents or events cannot occur. Such measures include but are not limited to protective circuits and error prevention circuits for safe design, redundant design, and structural design.
- In the event that any or all SANYO Semiconductor Co.,Ltd. products described or contained herein are controlled under any of applicable local export control laws and regulations, such products may require the export license from the authorities concerned in accordance with the above law.
- No part of this publication may be reproduced or transmitted in any form or by any means, electronic or mechanical, including photocopying and recording, or any information storage or retrieval system, or otherwise, without the prior written consent of SANYO Semiconductor Co.,Ltd.
- Any and all information described or contained herein are subject to change without notice due to product/technology improvement, etc. When designing equipment, refer to the "Delivery Specification" for the SANYO Semiconductor Co.,Ltd. product that you intend to use.
- Information (including circuit diagrams and circuit parameters) herein is for example only; it is not guaranteed for volume production.
- Upon using the technical information or products described herein, neither warranty nor license shall be granted with regard to intellectual property rights or any other rights of SANYO Semiconductor Co.,Ltd. or any third party. SANYO Semiconductor Co.,Ltd. shall not be liable for any claim or suits with regard to a third party's intellectual property rights which has resulted from the use of the technical information and products mentioned above.

This catalog provides information as of March, 2007. Specifications and information herein are subject to change without notice.