



SANYO Semiconductors

DATA SHEET

LA73054

Monolithic Linear IC
For DVD Player
Video Signal Driver

Overview

The LA73054 is a video signal driver for DVD player.

Functions

- 6 Channel
- Clamp
- Amplifier
- 75Ω driver
- Y/C-MIX
- Output Mute
- DC voltage output for S1 and S2
- 7MHz/14MHz LPF

Specifications

Maximum Ratings at Ta = 25°C

Parameter	Symbol	Conditions	Ratings	Unit
Maximum supply voltage	V _{CC} max		7.0	V
Allowable power dissipation	Pd max	Ta ≤ 75°C *	800	mW
Operating temperature	T _{opr}		-20 to +75	°C
Storage temperature	T _{stg}		-40 to +150	°C

* Mounted on a board : 114.3×76.1×1.6mm³, glass epoxy board.

Recommended Operating Conditions at Ta = 25°C

Parameter	Symbol	Conditions	Ratings	Unit
Recommended supply voltage	V _{CC}		5.0	V
Operating supply voltage range	V _{CC} opg		4.75 to 5.25	V
Input pin voltage application range	V _{IN}	V _{CC} opg + 0.3 ≤ 7V	-0.3 to V _{CC} opg + 0.3	V

■ Any and all SANYO Semiconductor products described or contained herein do not have specifications that can handle applications that require extremely high levels of reliability, such as life-support systems, aircraft's control systems, or other applications whose failure can be reasonably expected to result in serious physical and/or material damage. Consult with your SANYO Semiconductor representative nearest you before using any SANYO Semiconductor products described or contained herein in such applications.

■ SANYO Semiconductor assumes no responsibility for equipment failures that result from using products at values that exceed, even momentarily, rated values (such as maximum ratings, operating condition ranges, or other parameters) listed in products specifications of any and all SANYO Semiconductor products described or contained herein.

SANYO Semiconductor Co., Ltd.

TOKYO OFFICE Tokyo Bldg., 1-10, 1 Chome, Ueno, Taito-ku, TOKYO, 110-8534 JAPAN

LA73054

Electrical Characteristics at Ta = 25°C, VCC = 5V

Parameter	Symbol	Input Signal				Output Point	Test Conditions	Ratings			Unit	Control Voltage Unit : V										SW Control									
		Point	Signal	Freq [Hz]	Amplitude [p-p]			min	typ	max		V3	V4	V5	V9	V10	V12	V13	V15	V36	S21	S28	S23	S31	S25	S33					
Current drain	I _{CC}					V _{CC1} V _{CC21} V _{CC22}	The sum of current flowing through V _{CC1} , V _{CC21} and V _{CC22} at no signal	52	65	78	mA	3.3	0	0	0	0	0	0	0	0	0	0	0	0	0	0	0	ON	ON		
GAIN at 6dB For two drives	G33L	V _{IN2}	SG5		1V	T33	Measure GAIN for input at each output.	5.6	5.9	6.4	dB			0	0	0	0	0	0	0	0	0	0	0	0	0	ON	ON			
	G31L	V _{IN6}	SG6		714mV	T31																									
	G28L	V _{IN8}	SG5		1V	T28																									
	G25L	V _{IN11}	SG5		1V	T25																									
	G23L	V _{IN14}	SG6		1V	T23																									
	G21L	V _{IN16}	SG6		1V	T21																									
GAIN at 9dB For two drives	G33H	V _{IN2}	SG5		709mV	T33	Measure GAIN for input at each output.	8.55	8.9	9.45	dB			0	0	0	0	0	0	0	0	0	0	0	0	3.3	0	ON	ON		
	G31H	V _{IN6}	SG6		507mV	T31																									
	G28H	V _{IN8}	SG5		709mV	T28																									
	G25H	V _{IN11}	SG5		709mV	T25																				3.3	0				
	G23H	V _{IN14}	SG6		709mV	T23																									
	G21H	V _{IN16}	SG6		709mV	T21																									
GAIN at 6dB For one drive Two-drive mode	G33L1	V _{IN2}	SG5		1V	T33	Measure GAIN for input at each output.	5.6	6.1	6.4	dB			0	0	0	0	0	0	0	0	0	0	0	0	0	0	ON	OFF		
	G31L1	V _{IN6}	SG6		714mV	T31																									
	G28L1	V _{IN8}	SG5		1V	T28																									
	G25L1	V _{IN11}	SG5		1V	T25																							OFF	ON	
	G23L1	V _{IN14}	SG6		1V	T23																									
	G21L1	V _{IN16}	SG6		1V	T21																									
GAIN at 9dB For one drive Two-drive mode	G33H1	V _{IN2}	SG5		709mV	T33	Measure GAIN for input at each output.	8.55	9.1	9.45	dB			0	0	0	0	0	0	0	0	0	0	0	0	3.3	0	ON	OFF		
	G31H1	V _{IN6}	SG6		507mV	T31																									
	G28H1	V _{IN8}	SG5		709mV	T28																									
	G25H1	V _{IN11}	SG5		709mV	T25																				3.3	0	OFF	ON		
	G23H1	V _{IN14}	SG6		709mV	T23																									
	G21H1	V _{IN16}	SG6		709mV	T21																									
Output GAIN ratio (composite/S)	Δ33/31	V _{IN2}	SG5		709mV	T33	Calculate the GAIN ratio at two outputs.	-0.5	0	0.5	%			0	0	0	0	0	0	0	0	0	0	0	3.3	0	ON	OFF			
	Δ33/28	V _{IN6}	SG6		507mV	T31																									
	Δ31/28	V _{IN8}	SG5		709mV	T28																									
Output GAIN ratio (component)	Δ25/23	V _{IN11}	SG5		709mV	T25	Calculate the GAIN ratio at two outputs.	-0.5	0	0.5	%			0	0	0	0	0	0	0	0	0	0	3.3	0	OFF	ON				
	Δ25/21	V _{IN14}	SG6		709mV	T23																									
	Δ23/21	V _{IN16}	SG5		709mV	T21																									
f characteristic 7MHz Attenuation amount	F33L	V _{IN2}	SG3	7M	1V	T33	Measure GAIN for input at each output and calculate the attenuation amount for "6dB GAIN."	-2	-0.8	0.4	dB			0	0	0	0	0	0	0	0	0	0	0	0	0	ON	ON			
	F31L	V _{IN6}	SG2	7M	714mV	T31																									
	F28L	V _{IN8}	SG1	7M	1V	T28																									
	F25L1	V _{IN11}	SG1	7M	1V	T25																									
	F23L1	V _{IN14}	SG4	7M	1V	T23																									
	F21L1	V _{IN16}	SG4	7M	1V	T21																									
f characteristic 27MHz Attenuation amount	F33H	V _{IN2}	SG3	27M	1V	T33	Measure GAIN for input at each output and calculate the attenuation amount for "6dB GAIN."		-29	-22	dB			0	0	0	0	0	0	0	0	0	0	0	0	0	ON	ON			
	F31H	V _{IN6}	SG2	27M	714mV	T31																									
	F28H	V _{IN8}	SG1	27M	1V	T28																									
	F25H1	V _{IN11}	SG1	27M	1V	T25																									
	F23H1	V _{IN14}	SG4	27M	1V	T23																									
	F21H1	V _{IN16}	SG4	27M	1V	T21																									

Continued on next page.

LA73054

Continued from preceding page.

Parameter	Symbol	Input Signal				Output Point	Test Conditions	Ratings			Unit	Control Voltage Unit : V								SW Control			
		Point	Signal	Freq [Hz]	Amplitude [p-p]			min	typ	max		V3	V4	V5	V9	V10	V12	V13	V15	V36	S21	S28	S23
f characteristic of GAIN 14MHz Attenuation amount	F25L2	V _{IN11}	SG1	14M	1V	T25	Measure GAIN for input at each output and calculate the attenuation amount for "6dB GAIN."	-1.9	-0.7	0.5	dB			0	0	0	0	3.3	0	0	ON	ON	
	F23L2	V _{IN14}	SG4	14M	1V	T23																	
	F21L2	V _{IN16}	SG4	14M	1V	T21																	
f characteristic of GAIN 54MHz Attenuation amount	F25H2	V _{IN11}	SG1	54M	1V	T25			-39	-30	dB			0	0	0	0	3.3	0	0	ON	ON	
	F23H2	V _{IN14}	SG4	54M	1V	T23																	
	F21H2	V _{IN16}	SG4	54M	1V	T21																	
MUTE voltage	V21MD					T21	Measure the pin voltage.	2.1	2.5	2.9	V			3.3	0	0	0	0	0	0	ON	ON	
	V23MD					T23																	
	V25MD					T25																	
	V28MD					T28								0				3.3					
	V31MD					T31																	
	V33MD					T33																	
DC for SQ	VSQ					T30	Measure the pin voltage at V _{CC} = 4.75 to 5.25V	4.1	4.4	4.7	V	3.3	0	0	0	0	0	0	0	0	ON	ON	
DC for LB	VLB					T30		2.05	2.2	2.35	V	0	3.3	0	0	0	0	0	0	0	ON	ON	
DC for 4 : 3	V43					T30		0	0	0.35	V	0	0	0	0	0	0	0	0	0	ON	ON	

LA73054

Design Guarantee Items at Ta = 25°C, VCC = 5V

Parameter	Symbol	Input Signal				Output Point	Test Conditions	Ratings			Unit	Control Voltage Unit : V								SW Control			
		Point	Signal	Freq [Hz]	Amplitude [p-p]			min	typ	max		V3	V4	V5	V9	V10	V12	V13	V15	V36	S21	S28	
																					S23	S31	S25
f characteristic at group delay At 7MHz (Interlace)	GD33	V _{IN2}	SG3	7M	1V	T33	Difference in group delay at 7MHz for 100kHz of each output		±10	±15	ns			0	0	0	0	0	0	0	0	0	0
	GD31	V _{IN6}	SG2	7M	714mV	T31																	
	GD28	V _{IN8}	SG1	7M	1V	T28																	
	GD25-1	V _{IN11}	SG1	7M	1V	T25																	
	GD23-1	V _{IN14}	SG4	7M	1V	T23																	
	GD21-1	V _{IN16}	SG4	7M	1V	T21																	
f characteristic of group delay At 14MHz (progressive)	GD25-2	V _{IN11}	SG1	14M	1V	T25	Difference in group delay at 14MHz for 100kHz of each output		±15	±20	ns			0	0	0	0	3.3	0	0	0	0	
	GD23-2	V _{IN14}	SG4	14M	1V	T23																	
	GD21-2	V _{IN16}	SG4	14M	1V	T21																	
DG	DG33	V _{IN2}	SG7	3.58M	1V	T33	Calculate, in percentage, the amplitude of SIN wave on the white level relative to that of SIN wave on the black level of each output signal.		1	2	%			0	0	0	0	0	0	0	0	0	
	DG28	V _{IN8}	SG7	3.58M	1V	T28																	
	DG25	V _{IN11}	SG7	3.58M	1V	T25																	
	DGMIX	V _{IN6}	SG2	3.58M	286mV	T33																	
		V _{IN8}	SG7	Y component	1V																		
DP	DP33	V _{IN2}	SG7	3.58M	1V	T33	Measure the difference in phase of SIN wave on the white level relative to that of SIN wave on the black level of each output signal.	-1	0.5	1	deg			0	0	0	0	0	0	0	0	0	
	DP28	V _{IN8}	SG7	3.58M	1V	T28																	
	DP25	V _{IN11}	SG7	3.58M	1V	T25																	
	DPMIX	V _{IN6}	SG2	3.58M	286mV	T33																	
		V _{IN8}	SG7	Y component	1V																		
Cross-talk	CT33	V _{IN2}	SG3	4M	1V	T33	Measure the 4MHz component of output in the no-input route and specify this in a percentage relative to the magnitude of 4MHz of other outputs.		-60	-55	dB			0	0	0	0	0	0	0	0	0	
	CT31	V _{IN6}	SG2	4M	1V	T31																	
	CT28	V _{IN8}	SG1	4M	1V	T28																	
	CT25	V _{IN11}	SG1	4M	1V	T25																	
	CT23	V _{IN14}	SG4	4M	1V	T23																	
	CT21	V _{IN16}	SG4	4M	1V	T21																	
Video S/N ratio	SN33	V _{IN2}	SG5		1V	T33	Measure S/N of the output signal with a noise meter (LPF 10MHz, HPF 100kHz) and specify this in dB.		-79	-77	dB			0	0	0	0	0	0	0	0		
	SN28	V _{IN8}	SG5		1V	T28																	
	SN25	V _{IN11}	SG5		1V	T25																	
	SNMIX	V _{IN8}	SG5		1V	T33																	
Linearity of RGB signal	LN25	V _{IN11}	SG8		0.7V	T25	Measure GAIN of the output signal and specify this in a percentage relative to GAIN at 0.35Vp-p input.	95	99	100	%			0	0	3.3	0	0	0	0	0		
	LN23	V _{IN14}	SG8		0.7V	T23																	
	LN21	V _{IN16}	SG8		0.7V	T21																	
		V _{IN2}	SG5		1V																		

Caution: The control voltage of V19 and V35 is 0 V for all of above items. SG8 is the signal determined by removing SYNC from SG5.

Package Dimensions

unit : mm

3247A

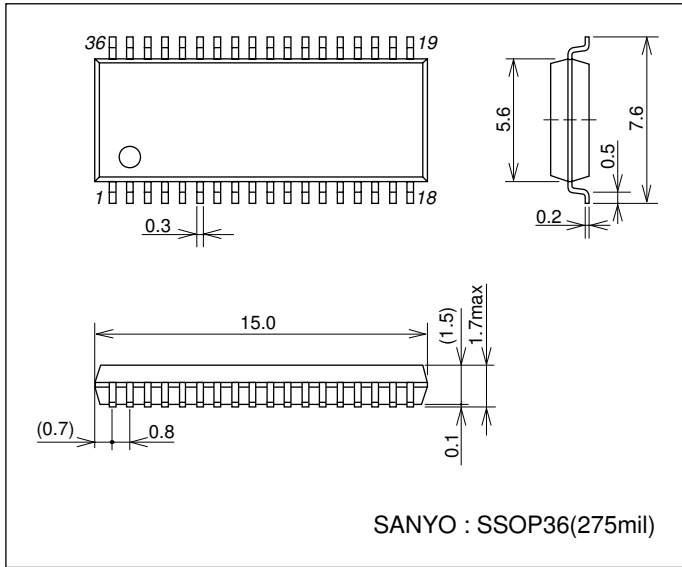

Control Pin Function Table

Pin No.	Control	0 to 0.7V (LOW)	2.6 to 5V (HIGH)
36	AMP-GAIN changeover for composite/S	6dB	9dB
15	AMP-GAIN changeover for component	6dB	9dB
35	Drive current changeover for composite/S	Two-system drive	Single-system drive
19	Drive current changeover for component	Two-system drive	Single-system drive
5	Mute control for composite/S	With pin 10 at LOW	No mute
		With pin 10 at HIGH	No mute
12	Component mute control	No mute	Mute of pins 25, 32, and 21
9	Y/C-MIX control	At composite	At Y/C-MIX
10	Pin 11 input form changeover	Clamp input	Pedestal clamp input
13	Component LPF characteristics changeover	Interlace compatible	Progressive compatible

* Pin 2 is connected to GND at Y/C-MIX.

Pin 3	Pin 4	Pin 30 output DC
0 to 0.7V	0 to 0.7V	LOW (0V) → For 4:3 mode
0 to 0.7V	2.6 to 5V	MIDDLE (2.2V) → For the letter box mode
2.6 to 5V	0 to 0.7V	HIGH (5V) → For the squeeze mode
2.6 to 5V	2.6 to 5V	Prohibited

* The voltage to be applied to all control pins must not be higher than the one applied to V_{CC} and lower than the one applied to GND.

* All of control pins must not be used in the OPEN state.

LA73054

Block Diagram and Application Circuit Example

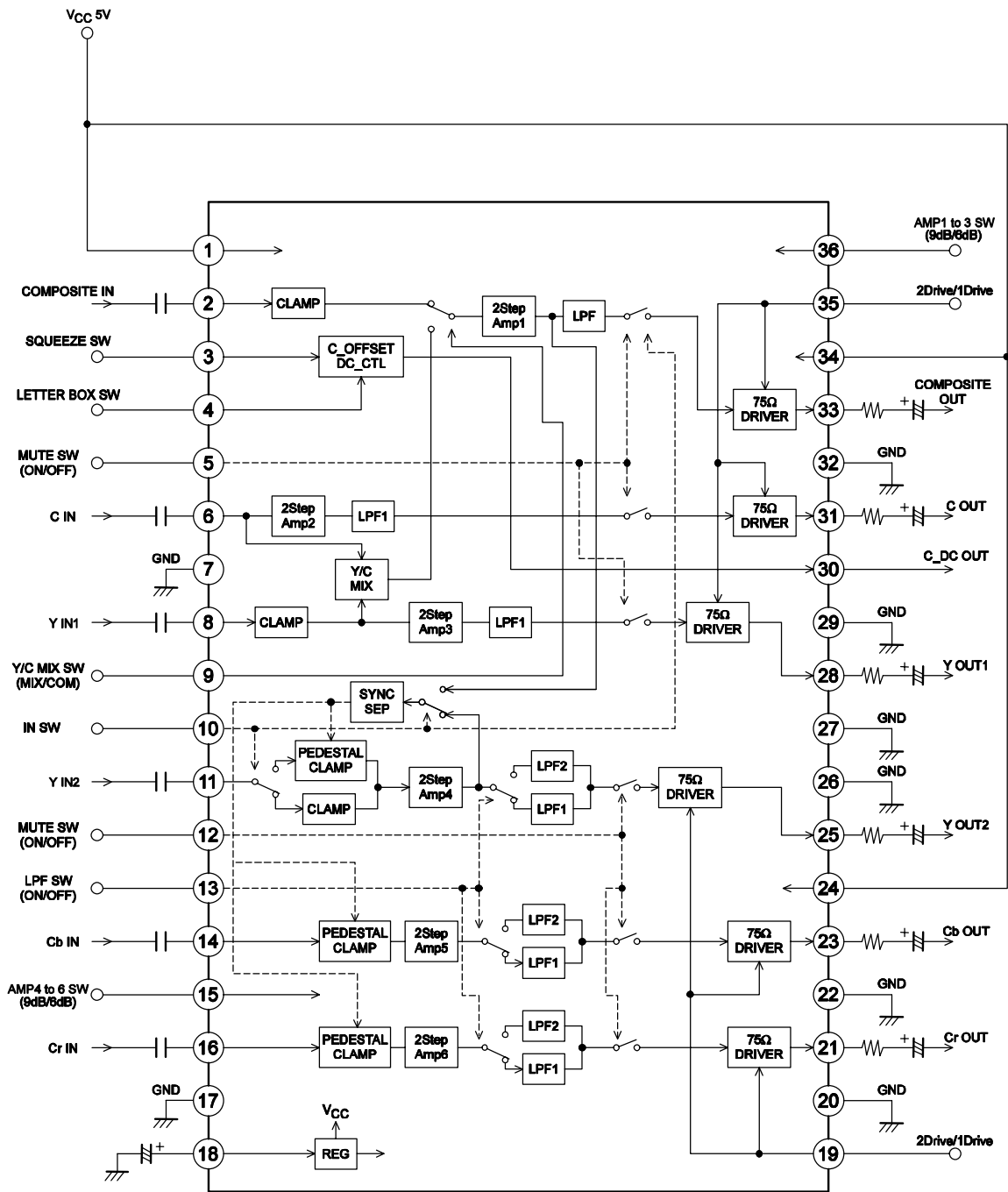

OMB0674

LA73054

Pin Functions

Pin No.	Pin Name	I/O	Terminal Voltage	Conditions	Equivalent Circuit
1 24 34	V _{CC} 1 V _{CC} 22 V _{CC} 21	P	5V	V _{CC}	
2	COMPOSITE.IN	I	2.3V	When selecting Y/C-MIX off and gain (L)	
3 4 5 9 10 12 13 15 19 35 36	SQUEEZE.SW LETTER-BOX.SW MUTE.SW1 Y/C-MIX.SW RGB.SW MUTE.SW2 LPF.SW AMP.SW2 DRIVE.SW2 DRIVE.SW1 AMP.SW1	I	2V	OPEN	
6	CHROMA.IN	I	2.8V	Always	
7 17 20 22 26 27 29 32	GND11 GND12 GND26 GND25 GND24 GND23 GND22 GND21	P	0V	GND	
8	Y.IN1	I	2.3V	When selecting gain (L)	

Continued on next page.

LA73054

Continued from preceding page.

Pin No.	Pin Name	I/O	Terminal Voltage	Conditions	Equivalent Circuit
11	Y.IN2	I	2.3V	When selecting component and gain (L)	
14 16	Cb.IN Cr.IN	I	2.9V	When selecting gain (L)	
18	REG	O	2V	470μF toward to GND.	
21 23	Cr.OUT Cb.OUT	O	2.5V	Except mute	
25 28 33	Y.OUT2 Y.OUT1 COMPOSITE.OUT		1.35V		
30	C_DC.OUT	O	4.4V	When squeeze mode	

Continued on next page.

LA73054

Continued from preceding page.

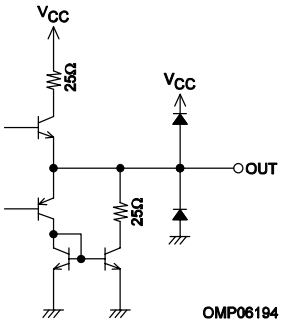
Pin No.	Pin Name	I/O	Terminal Voltage	Conditions	Equivalent Circuit
31	CHROMA.OUT	O	2.4V	When selecting gain (L) Except mute	 <p style="text-align: right; margin-right: 50px;">OMP06194</p>

LA73054

Test Circuit

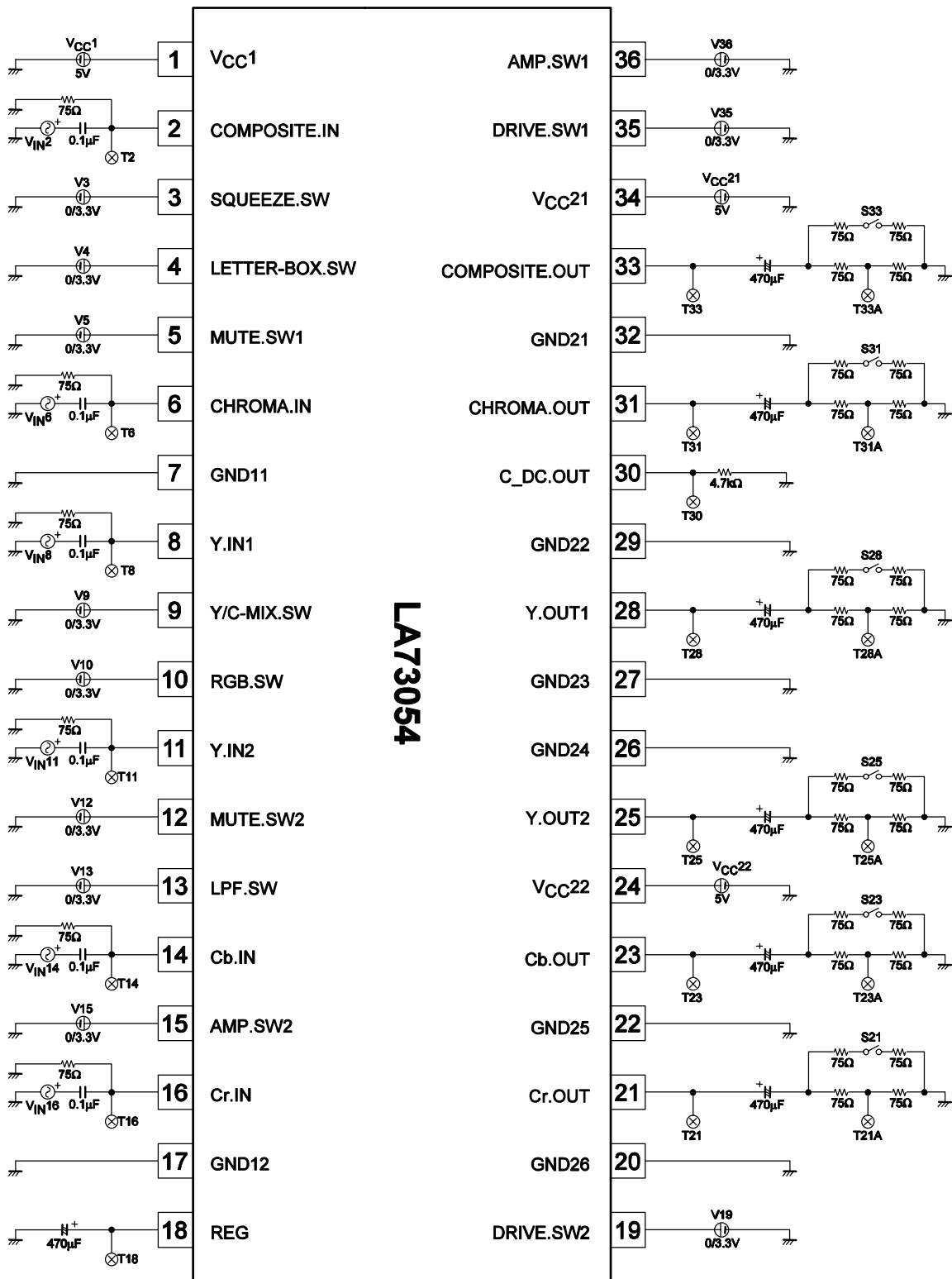

OMB06074

Test input signal

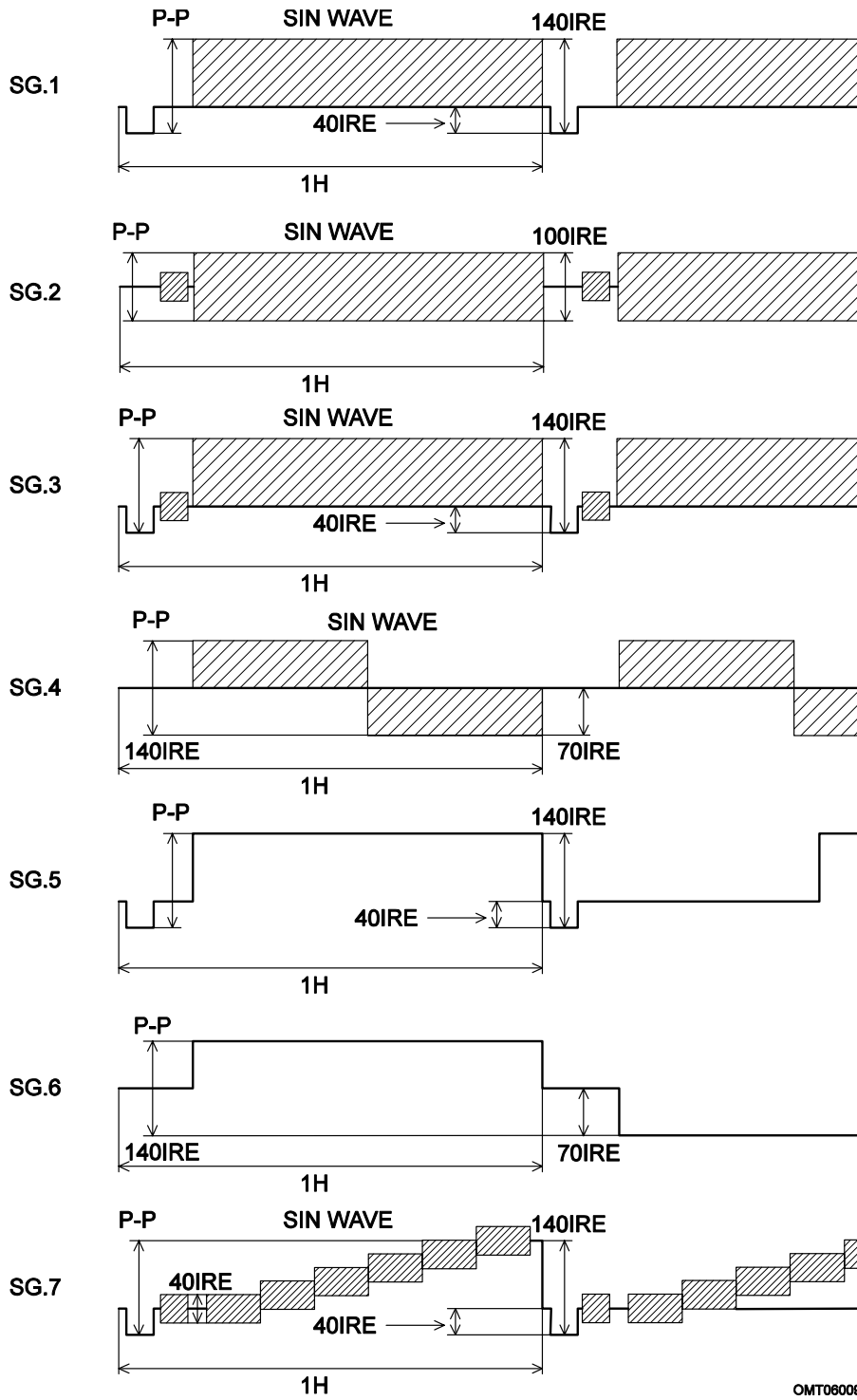

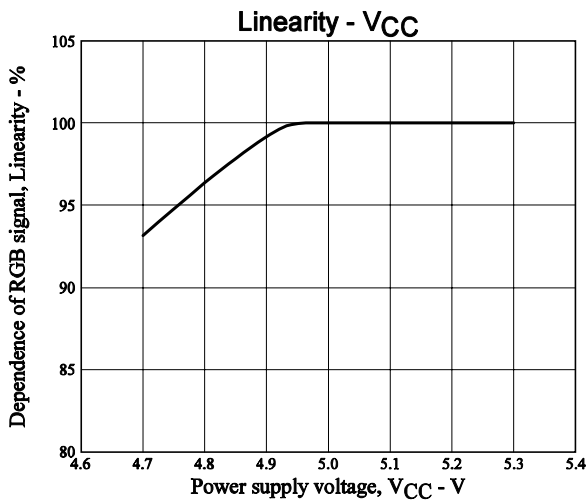

- Specifications of any and all SANYO Semiconductor products described or contained herein stipulate the performance, characteristics, and functions of the described products in the independent state, and are not guarantees of the performance, characteristics, and functions of the described products as mounted in the customer's products or equipment. To verify symptoms and states that cannot be evaluated in an independent device, the customer should always evaluate and test devices mounted in the customer's products or equipment.
- SANYO Semiconductor Co., Ltd. strives to supply high-quality high-reliability products. However, any and all semiconductor products fail with some probability. It is possible that these probabilistic failures could give rise to accidents or events that could endanger human lives, that could give rise to smoke or fire, or that could cause damage to other property. When designing equipment, adopt safety measures so that these kinds of accidents or events cannot occur. Such measures include but are not limited to protective circuits and error prevention circuits for safe design, redundant design, and structural design.
- In the event that any or all SANYO Semiconductor products (including technical data, services) described or contained herein are controlled under any of applicable local export control laws and regulations, such products must not be exported without obtaining the export license from the authorities concerned in accordance with the above law.
- No part of this publication may be reproduced or transmitted in any form or by any means, electronic or mechanical, including photocopying and recording, or any information storage or retrieval system, or otherwise, without the prior written permission of SANYO Semiconductor Co., Ltd.
- Any and all information described or contained herein are subject to change without notice due to product/technology improvement, etc. When designing equipment, refer to the "Delivery Specification" for the SANYO Semiconductor product that you intend to use.
- Information (including circuit diagrams and circuit parameters) herein is for example only; it is not guaranteed for volume production. SANYO Semiconductor believes information herein is accurate and reliable, but no guarantees are made or implied regarding its use or any infringements of intellectual property rights or other rights of third parties.

This catalog provides information as of March, 2006. Specifications and information herein are subject to change without notice.