

EFM32G880F128-STK development board

Users Manual



All boards produced by Olimex are ROHS compliant

Rev. Initial, March 2010
Copyright(c) 2010, OLIMEX Ltd, All rights reserved

INTRODUCTION

EFM32G880F128-STK development board provides easy way for developing and prototyping with the new EFM32G880F128 energy friendly microcontroller, produced by Energy Micro AS. The combination of the powerful 32-bit ARM Cortex-M3, innovative low energy techniques, short wake-up time from energy saving modes, and a wide selection of peripherals, the EFM32G880F128 microcontroller is well suited for any battery operated application as well as other systems requiring high performance and low-energy consumption.

EFM32G880F128-STK has DBG port for programming and debugging, UEXT, EXT, four user buttons, RESET button, buzzer, LCD and some of the GPIOs are on extension headers where you can connect your additional circuits. All this allows you to build a diversity of powerful applications to be used in a wide range of applications.

BOARD FEATURES

- MCU: **EFM32G880F128** 32 bit Cortex-M3™ with 128K Bytes Program Flash, 16K Bytes RAM, 85 GPIO, 8 Channel DMA, 12 bit ADC 1Msps, 3xUART/SPI, 2x low power UART, I2C, 3x 16bit TIMERS, 3x2 CC-PWM, SSC, RTC, WDT, up to 32MHz operation
- LCD custom display
- DEBUG connector with ARM 2x10 pin layout for programming/debugging with ARM-JTAG-EW
- UEXT connector
- EXT extension connector
- RS232 connector and driver
- Power jack
- Lithium coin battery holder
- RESET circuit , RESET button
- Four user buttons
- Buzzer
- On-board voltage regulator 3.3V with up to 800mA current
- Power supply filtering capacitor
- 32 Mhz crystal
- Extension headers for some of the uC ports + RST and power supply
- PCB: FR-4, 1.5 mm (0,062"), soldermask, silkscreen component print
- Dimensions: 77 x 64 mm (3.03 x 2.52")

ELECTROSTATIC WARNING

The EFM32G880F128-STK board is shipped in protective anti-static packaging. The board must not be subject to high electrostatic potentials. General practice for working with static sensitive devices should be applied when working with this board.

BOARD USE REQUIREMENTS

Cables: The cable you will need depends on the programmer/debugger you use. If you use ARM-JTAG-EW, you will need 1.8 m A-B USB cable.

Hardware: Programmer/Debugger – Olimex ARM Programmer: ARM-JTAG-EW.

Software: ARM C compiler and JTAG programmer.

PROCESSOR FEATURES

EFM32G880F128-STK board use High Performance ARM-based 32-bit microcontroller **EFM32G880F128** with these features:

- Memory Protection Unit
- Wake-up Interrupt Controller
- Flexible Energy Management System
 - 20 nA @ 3 V Shutoff Mode
 - 0.6 μ A @ 3 V Stop Mode, including Power-on Reset, Brown-out Detector, RAM and CPU retention
 - 0.9 μ A @ 3 V Deep Sleep Mode, including Real Time Clock with 32.768 kHz oscillator, Power-on Reset, Brown-out Detector, RAM and CPU retention
 - 45 μ A/MHz @ 3 V Sleep Mode
 - 180 μ A/MHz @ 3 V Run Mode, with code executed from flash
- 128 KB Flash
- 16 KB RAM
- 85 General Purpose I/O pins
 - Configurable Push-pull, Open-drain, pull-up/down, input filter, drive strength
 - Configurable peripheral I/O locations
 - 16 asynchronous external interrupts
- 8 Channel DMA Controller
- 8 Channel Peripheral Reflex System for autonomous inter-peripheral signaling
- External Bus Interface for up to 64 MB of external memory mapped space
- Hardware AES with 128/256-bit keys in 54/75 cycles
- Timers/Counters
 - 3 \times 16-bit Timer/Counter
 - 3 \times 3 Compare/Capture/PWM channels

- Dead-Time Insertion on TIMER0
- 16-bit Low Energy Timer
- 24-bit Real-Time Counter
- 3× 8-bit Pulse Counter
 - Asynchronous pulse counting/quadrature decoding
- Watchdog Timer with dedicated RC oscillator @ 50 nA
- Integrated LCD Controller for up to 4×40 segments
 - Voltage boost, adjustable contrast adjustment and autonomous animation feature
- Communication interfaces
 - 3× Universal Synchronous/Asynchronous Receiver/Transmitter
 - UART/SPI/SmartCard (ISO 7816)/IrDA
 - Triple buffered full/half-duplex operation
 - 4-16 data bits
 - Universal Asynchronous Receiver/Transmitter
 - Triple buffered full/half-duplex operation
 - 8-9 data bits
 - 2× Low Energy UART
 - Autonomous operation with DMA in Deep Sleep Mode
 - I²C Interface with SMBus support
 - Address recognition in Stop Mode
- Ultra low power precision analog peripherals
 - 12-bit 1 Msamples/s Analog to Digital Converter
 - Single ended or differential operation
 - On-chip temperature sensor
 - Conversion tailgating for predictable latency
 - 12-bit 500 ksamples/s Digital to Analog Converter
 - 2 single ended channels/1 differential channel
 - 2× Analog Comparator
 - Programmable speed/current
 - Capacitive sensing with up to 8 inputs
 - Supply Voltage Comparator
- Ultra efficient Power-on Reset and Brown-Out Detector
- 2-pin Serial Wire Debug interface
 - 1-pin Serial Wire Viewer
- Temperature range -40 to 85 °C
- Single power supply 1.8 to 3.8 V

BLOCK DIAGRAM

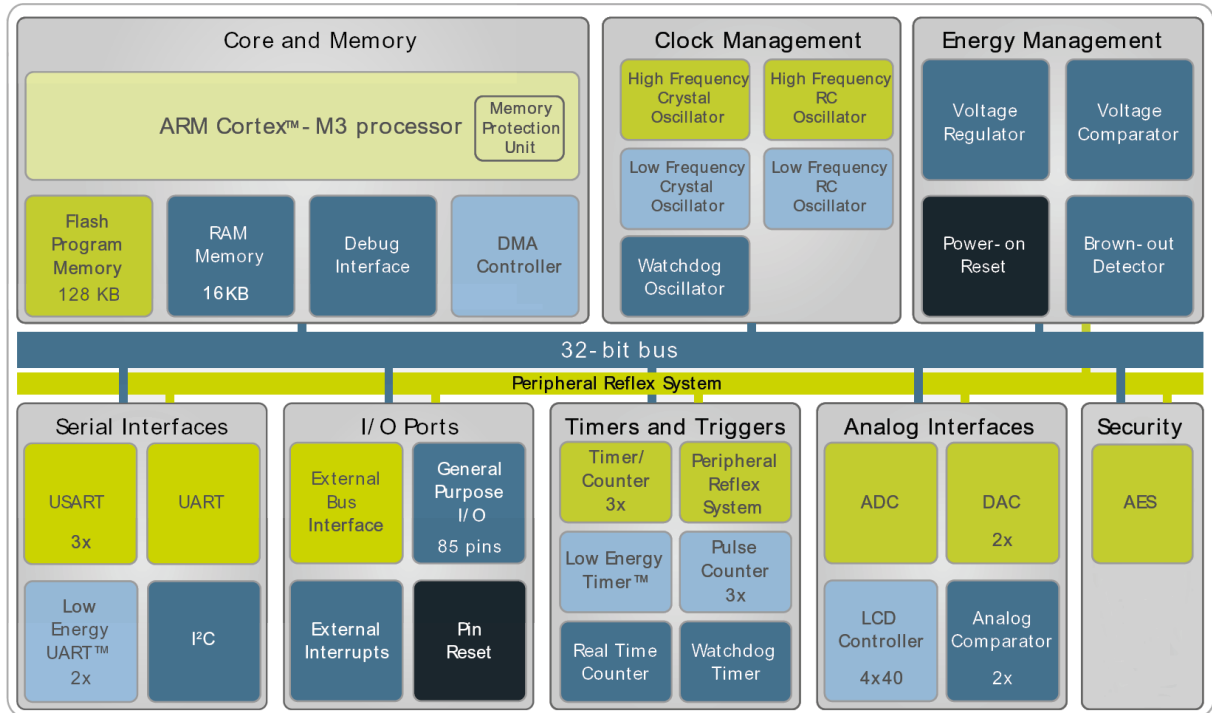

MEMORY MAP

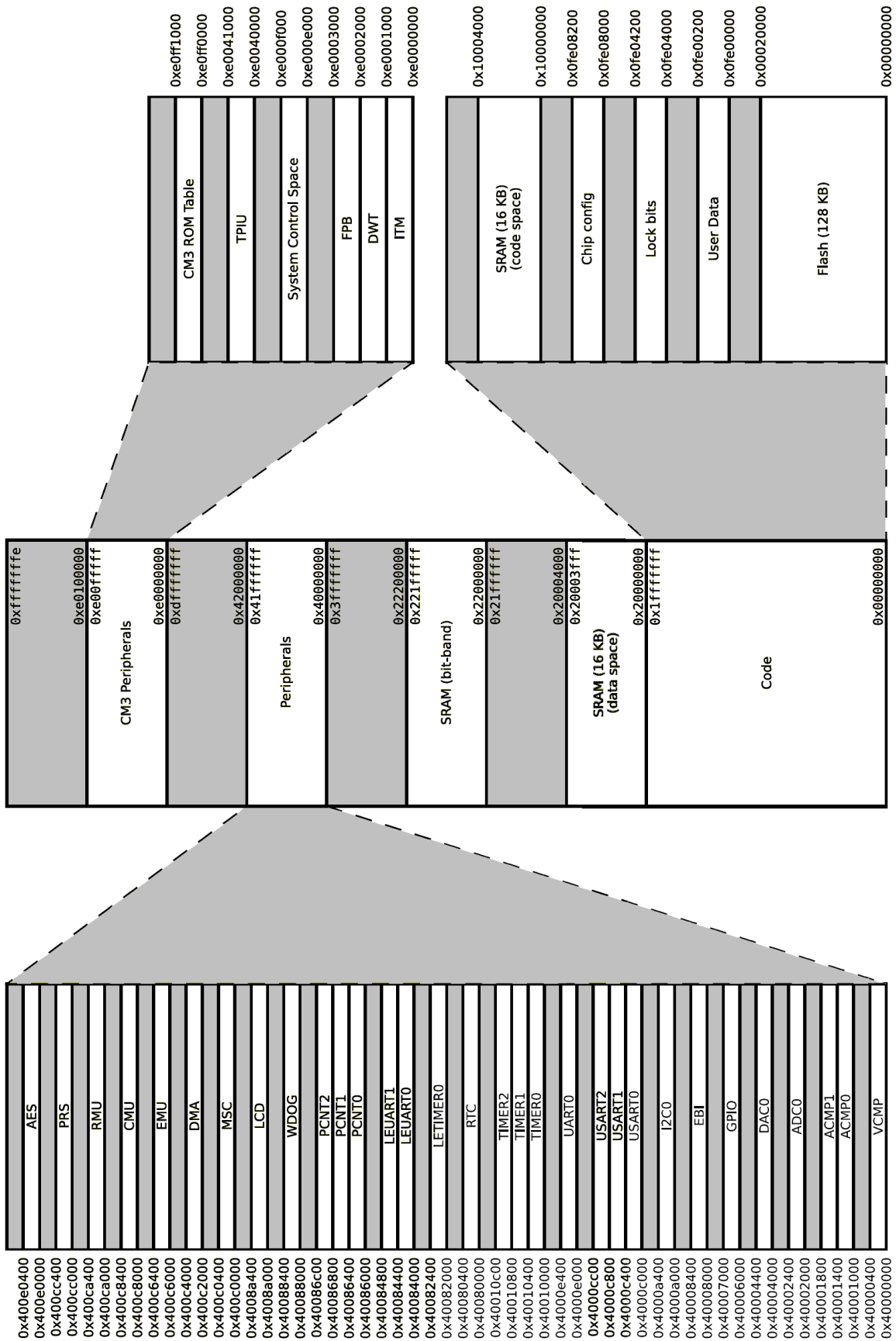

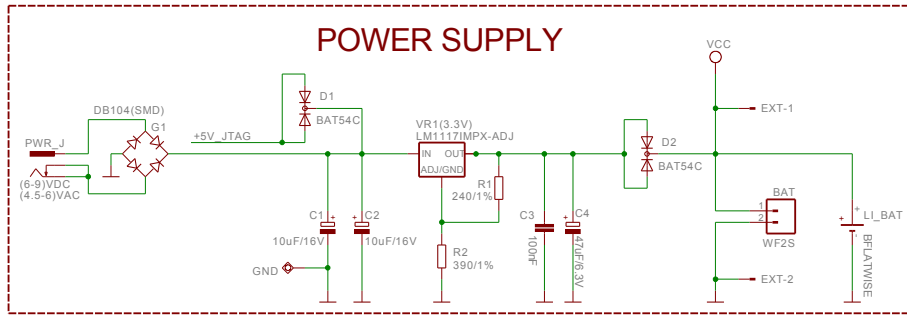
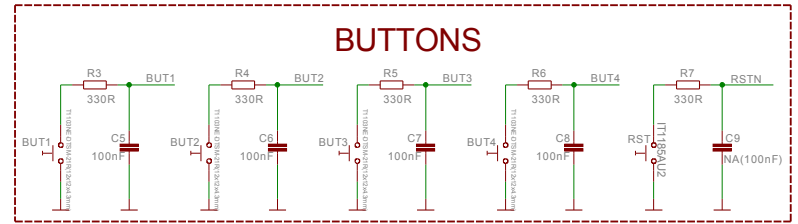
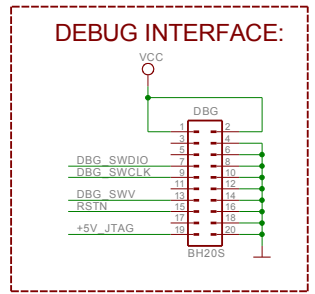
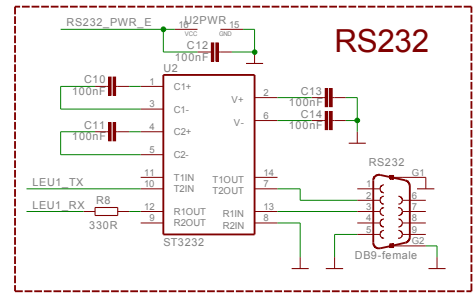
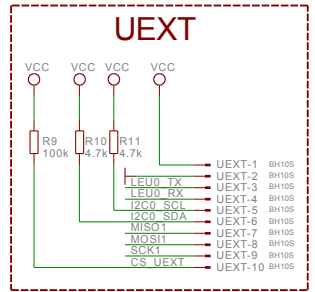
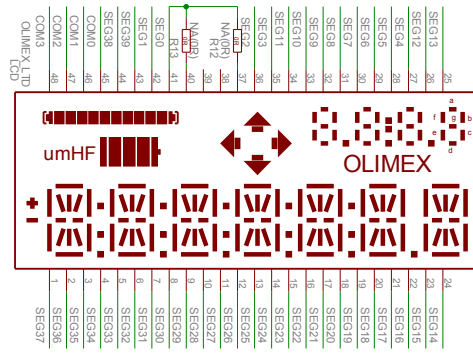
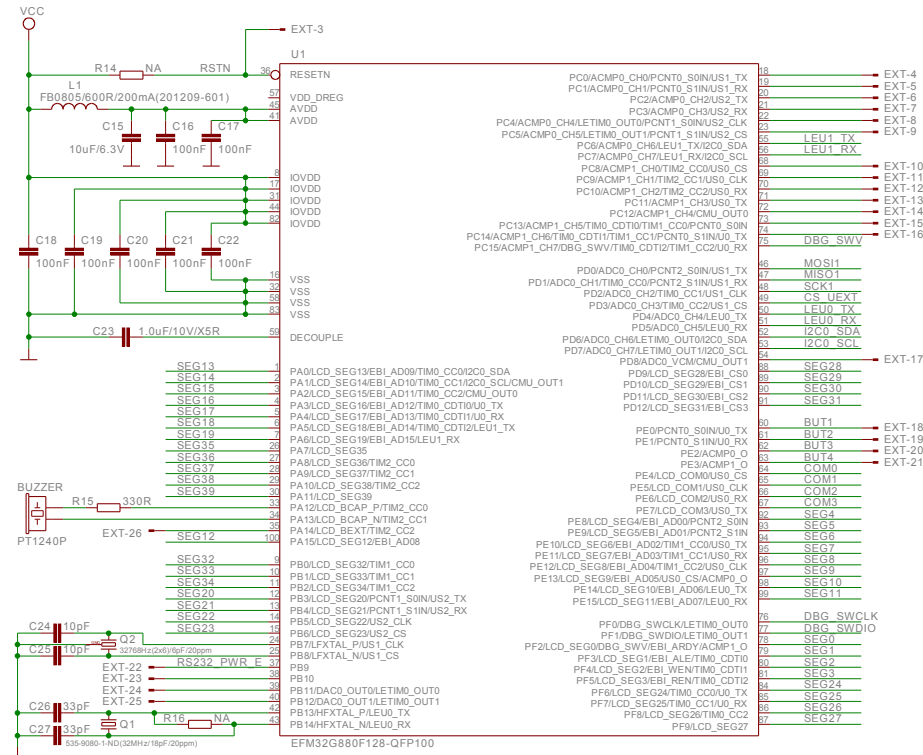

EFM32G880F128-STK

Rev. Initial
 COPYRIGHT(C) 2010
 WWW.OLIMEX.COM/DEV

BOARD LAYOUT

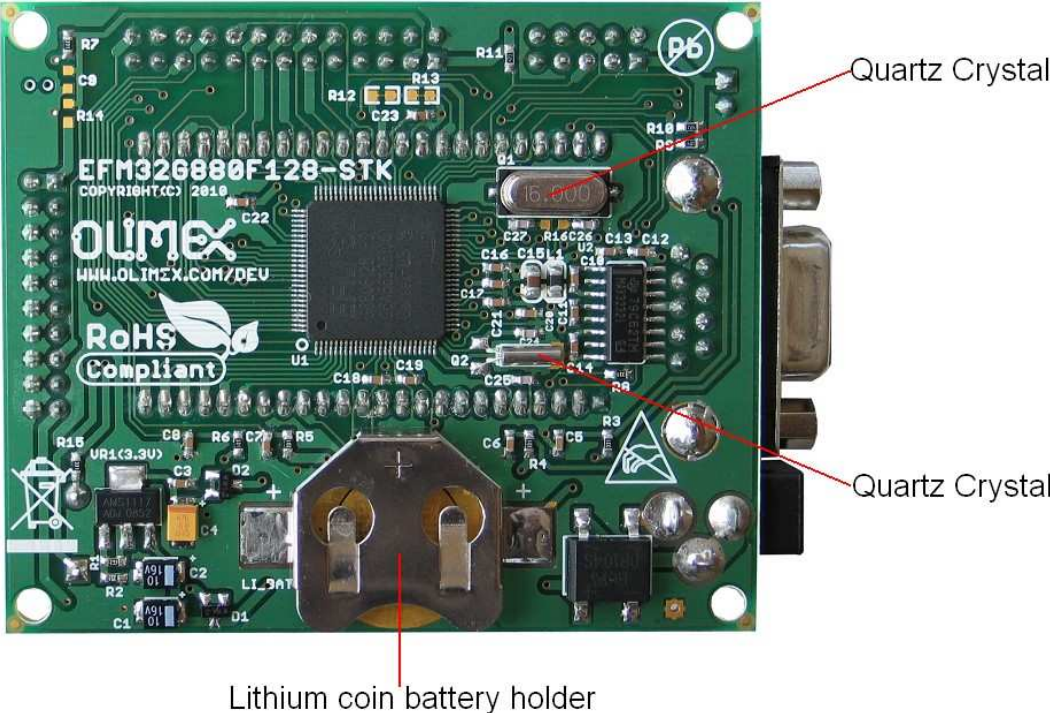
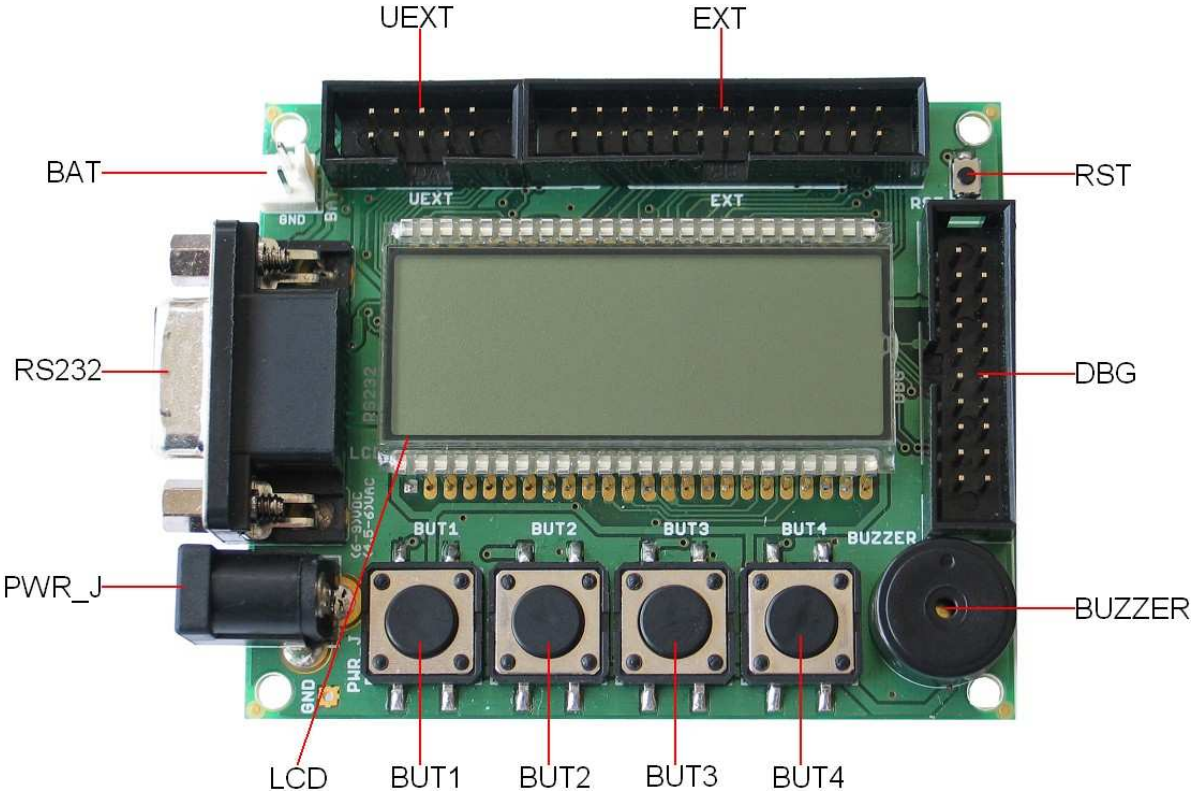

POWER SUPPLY CIRCUIT

EFM32G880F128-STK can take power from three sources:

- PWR connector where (6 - 9)VDC, or (4.5 - 6)VAC is applied by external power source.
- +5V_JTAG from DBG connector
- VCC (+3V) from BAT connector

RESET CIRCUIT

EFM32G880F128-STK reset circuit includes EXT pin 3, DBG connector pin 15, EFM32G880F128 pin 36 (RESETN) and RST button.

CLOCK CIRCUIT

Quartz crystal **Q1** - 32 MHz is connected to EFM32G880F128 pin 42 (PB13/HFXTAL_P/LEU0_TX) and pin 43 (PB14/HFXTAL_N/LEU0_RX).

Quartz crystal **Q2** - 32 768 Hz is connected to EFM32G880F128 pin 24 (PB7/LFXTAL_P/US1_CLK) and pin 25 (PB8/LFXTAL_N/US1_CS).

JUMPER DESCRIPTION

There are no jumpers on this board.

INPUT/OUTPUT

User button with name **BUT1** connected to EFM32G880F128 pin 60 (PE0/PCNT0_S0IN/U0_TX).

User button with name **BUT2** connected to EFM32G880F128 pin 61 (PE1/PCNT0_S1IN/U0_RX).

User button with name **BUT3** connected to EFM32G880F128 pin 62 (PE2/ACMP0_O).

User button with name **BUT4** connected to EFM32G880F128 pin 63 (PE3/ACMP1_O).

Reset button with name **RST** connected to EFM32G880F128 pin 36 (RESETN).

LCD

Buzzer connected to EFM2G880F128 pin 33 (PA12/LCD_BCAP_P/TIM2_CC0) via R15 (330 Ohm) and to pin 34 (PA13/LCD_BCAP_N/TIM2_CC1).

CONNECTOR DESCRIPTIONS

DBG

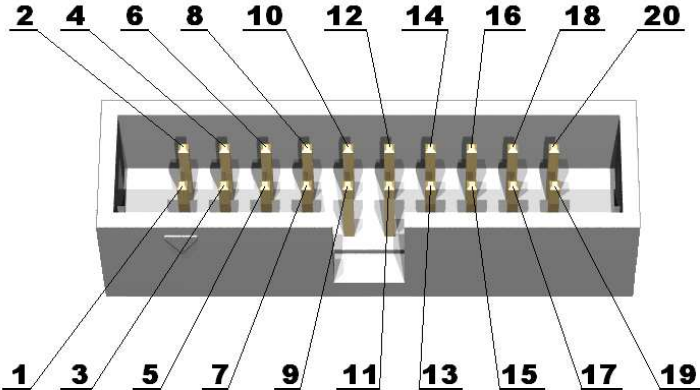

Pin #	Signal Name	Pin #	Signal Name
1	VCC	2	VCC
3	NC	4	GND
5	NC	6	GND
7	DBG_SWDIO	8	GND
9	DBG_SWCLK	10	GND
11	NC	12	GND
13	DBG_SWV	14	GND
15	RSTN	16	GND
17	NC	18	GND
19	+5V_JTAG	20	GND

3V BAT

Pin #	Signal Name
1	VCC
2	GND

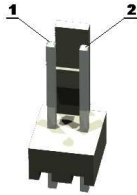

UEXT

Pin #	Signal Name
1	VCC
2	GND
3	LEU0_TX
4	LEU0_RX
5	I2C0_SCL
6	I2C0_SDA
7	MISO1
8	MOSI1
9	SCK1
10	CS_UEXT

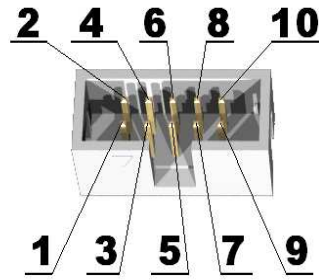

RS232

Pin #	Signal Name
1	NC
2	T2OUT
3	R1IN
4	NC
5	GND
6	NC
7	NC
8	NC
9	NC

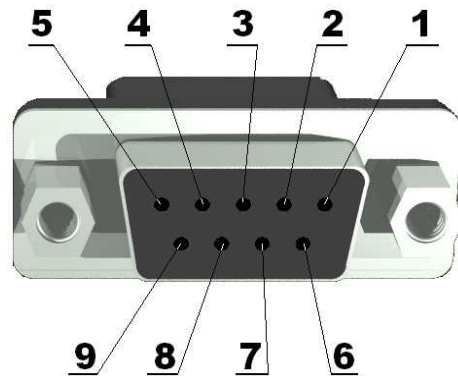

EXT

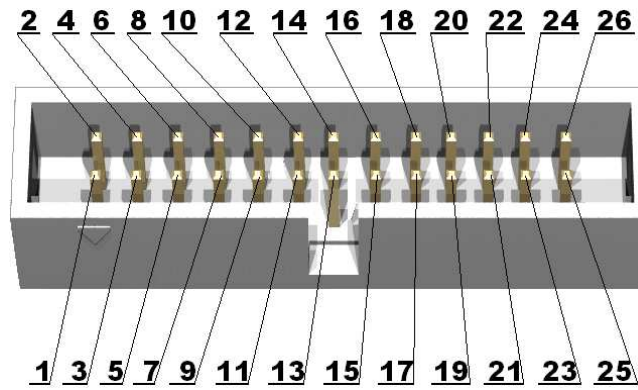

Pin #	Signal Name	Pin #	Signal Name
1	VCC	2	GND
3	RSTN	4	PC0
5	PC1	6	PC2
7	PC3	8	PC4
9	PC5	10	PC8
11	PC9	12	PC10
13	PC11	14	PC12
15	PC13	16	PC14
17	PD8	18	BUT1
19	BUT2	20	BUT3
21	BUT4	22	RS232_PWR_E
23	PB10	24	PB11
25	PB12	26	PA14

PWR JACK

Pin #	Signal Name
1	Power Input
2	GND

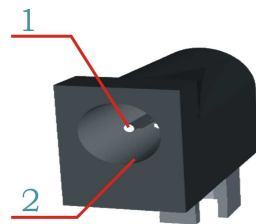

MECHANICAL DIMENSIONS

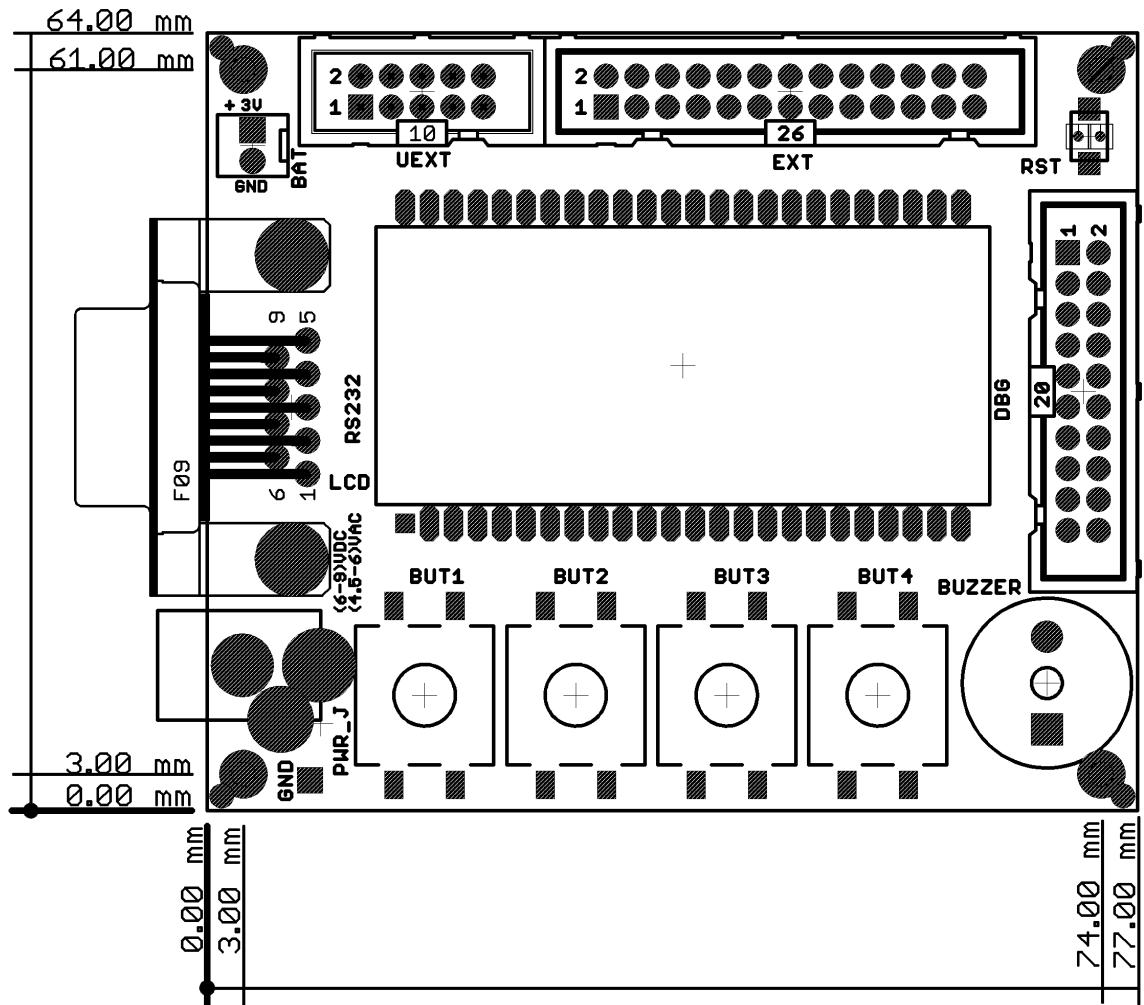

AVAILABLE DEMO SOFTWARE

- [EM-32G880F128-STK Demo project](#) for for EW-ARM 5.41

ORDER CODE

EFM32G880F128-STK – assembled and tested board, includes EFM32G880F128 microcontroller.

How to order?

You can order to us directly or by any of our distributors.

Check our web www.olimex.com/dev for more info.

Revision history:

REV. Initial - create March 2010

Disclaimer:

© 2010 Olimex Ltd. All rights reserved. Olimex®, logo and combinations thereof, are registered trademarks of Olimex Ltd. Other terms and product names may be trademarks of others.

The information in this document is provided in connection with Olimex products. No license, express or implied or otherwise, to any intellectual property right is granted by this document or in connection with the sale of Olimex products.

Neither the whole nor any part of the information contained in or the product described in this document may be adapted or reproduced in any material from except with the prior written permission of the copyright holder.

The product described in this document is subject to continuous development and improvements. All particulars of the product and its use contained in this document are given by OLIMEX in good faith. However all warranties implied or expressed including but not limited to implied warranties of merchantability or fitness for purpose are excluded.

This document is intended only to assist the reader in the use of the product. OLIMEX Ltd. shall not be liable for any loss or damage arising from the use of any information in this document or any error or omission in such information or any incorrect use of the product.