

SAM9-L9260 development board

Users Manual

Rev. B, June 2008

Copyright(c) 2009, OLIMEX Ltd, All rights reserved

INTRODUCTION:

SAM9-L9260 is a low cost development platform with ARM9 microcontroller, 64MB SDRAM and 512MB NAND Flash. The board has Ethernet 100Mbit controller, USB host, USB device, RS232 and 40 pin extension port with all unused SAM9260 ports available for add-on boards. SAM9-L9260 has waste amount of Flash and RAM and runs Linux, WindowsCE and other RTOS natively. The on-board RTC clock is equipped with a 3V Li backup battery.

BOARD FEATURES:

- MCU: AT91SAM9260 16/32 bit ARM9™ 200MHz operation
- 50MHz system (main) clock
- standard JTAG connector with ARM 2x10 pin layout for programming/debugging with ARM-JTAG
- 64 MB SDRAM
- 512MB NAND Flash (seen in Linux as silicon drive)
- Ethernet 100Mbit connector
- USB host and USB device connectors
- RS232 interface and drivers
- SD/MMC card connector
- one user button and one reset button
- one power and two status LEDs
- on board voltage regulator 3.3V with up to 800mA current
- single power supply: 5V DC required
- power supply filtering capacitor
- 18.432 Mhz crystal on socket
- extension header
- PCB: FR-4, 1.5 mm (0,062"), soldermask, silkscreen component print
- Dimensions: 100 x 80 mm (3.94 x 3.15")

ELECTROSTATIC WARNING:

The SAM9-L9260 board is shipped in protective anti-static packaging. The board must not be subject to high electrostatic potentials. General practice for working with static sensitive devices should be applied when working with this board.

BOARD USE REQUIREMENTS:

- Cables:** 1.8 meter USB A-B cable to connect with USB host.
Null modem RS232 female – female to connect with PC COM port.
- Hardware:** **ARM-JTAG, ARM-USB-OCD** or other compatible tool if you want to program this board with JTAG, usually with linux installed you can develop without the need for JTAG.
- Software:** The CD contains Linux 2.6 complete with source and binary in CD.

BOARD LAYOUT:

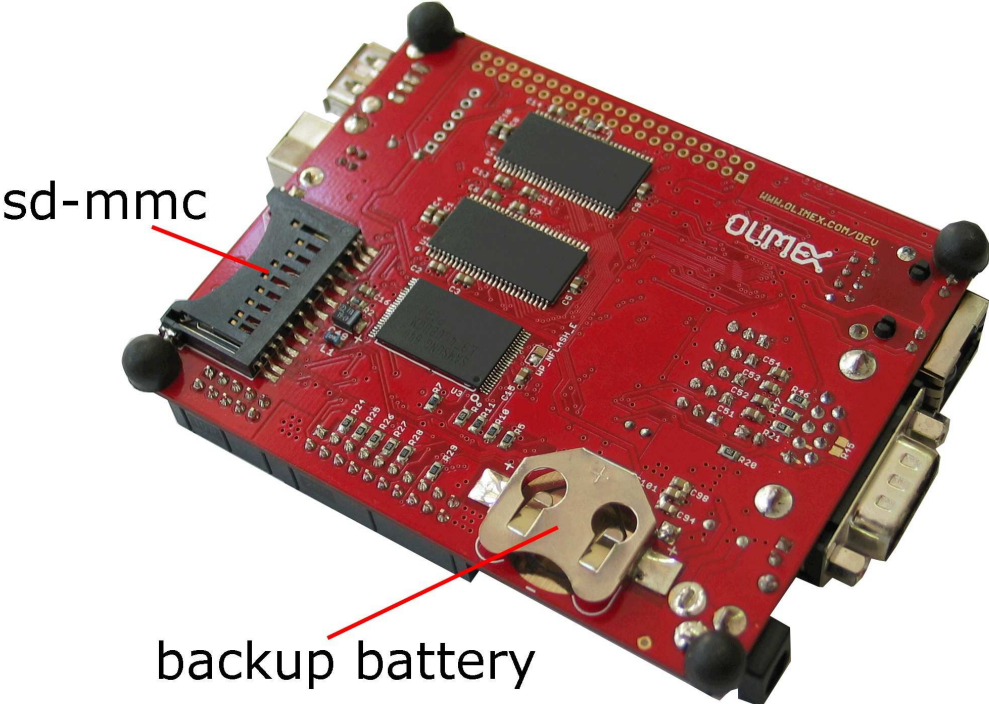
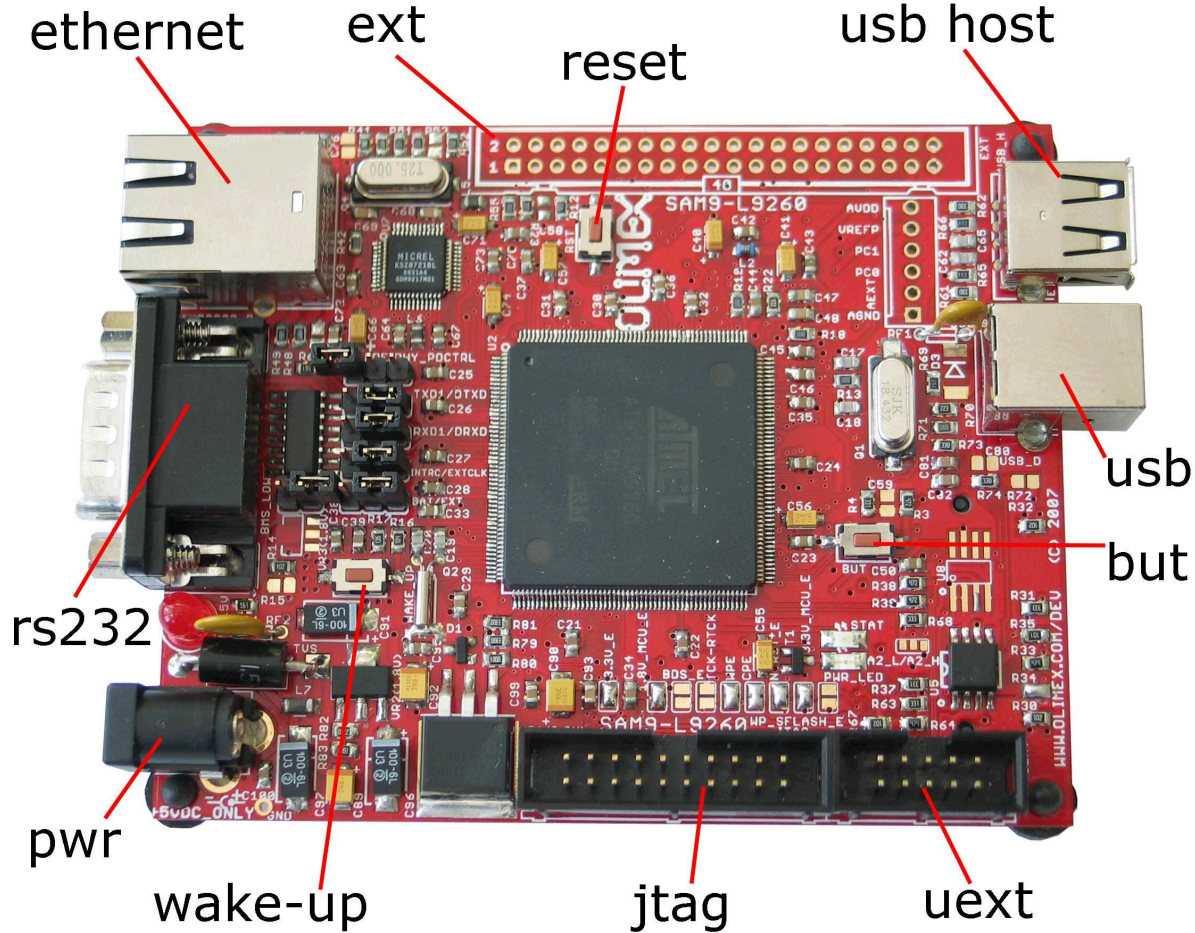

SAM9-L9260

Rev. B
COPYRIGHT(C) 2008, Olimex Ltd
http://www.olimex.com/dev

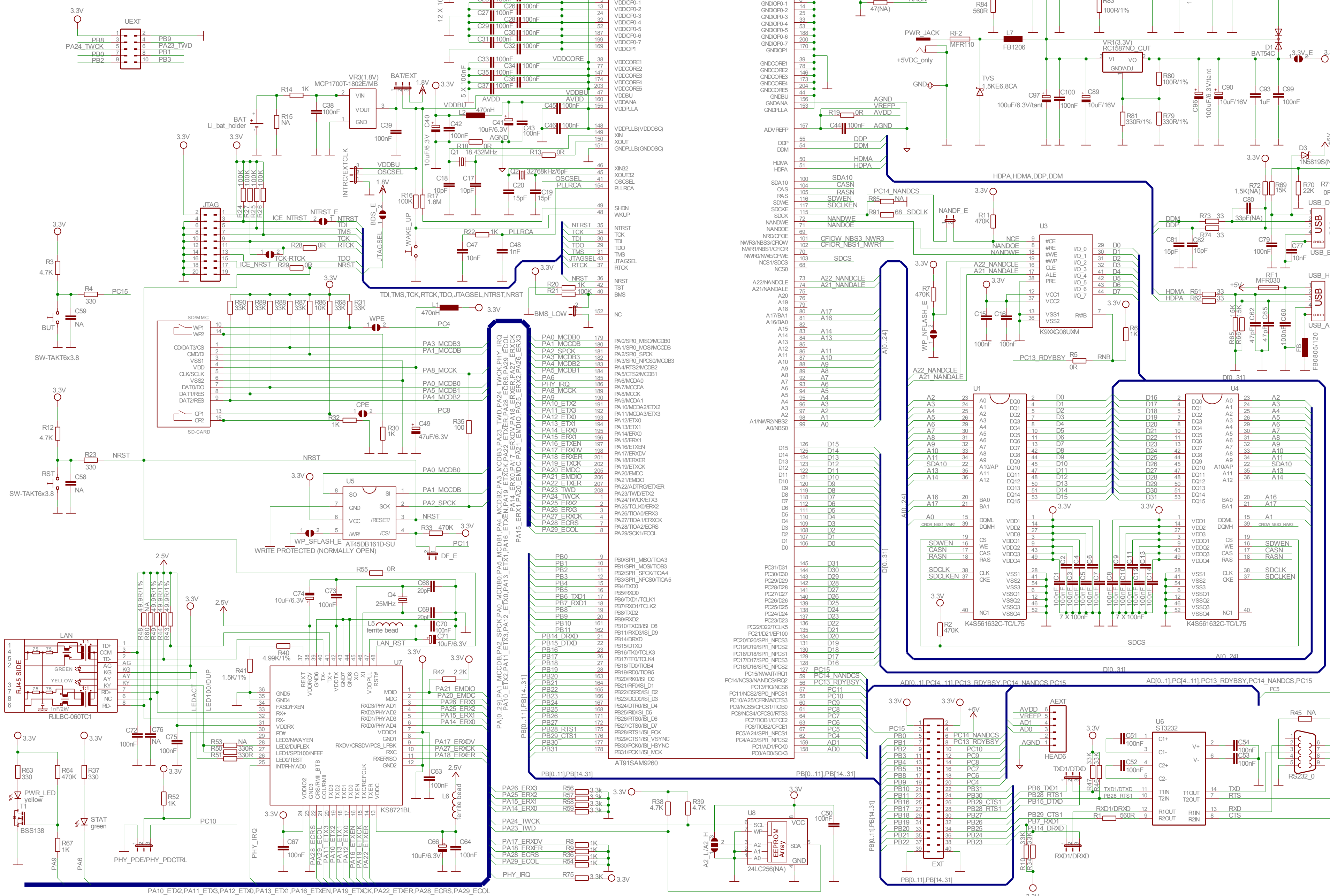

PA10_ETX2,PA11_ETX3,PA12_ETX0,PA13_ETX1,PA16_ETXEN,PA19_ETXCK,PA22_ETXER,PA28_ECERS,PA29_ECOLD

PROCESSOR FEATURES:

SAM9-L9260 board uses CPU **AT91SAM9260** from Atmel® with the following features:

- Incorporates the ARM926EJ-S™ ARM® Thumb® Processor
 - o DSP Instruction Extensions, ARM Jazelle® Technology for Java® Acceleration
- External Bus Interface (EBI)
 - o Supports SDRAM, Static Memory, ECC-enabled NAND Flash and CompactFlash®
- USB 2.0 Full Speed (12 Mbits per second) Device Port
 - o On-chip Transceiver, 2,432-byte Configurable Integrated DPRAM
- USB 2.0 Full Speed (12 Mbits per second) Host
- Ethernet MAC 10/100 Base T
 - o Media Independent Interface or Reduced Media Independent Interface
 - o 28-byte FIFOs and Dedicated DMA Channels for Receive and Transmit
- Bus Matrix
 - o Six 32-bit-layer Matrix
 - o Boot Mode Select Option, Remap Command
- Fully-featured System Controller, including
 - o Reset Controller, Shutdown Controller
 - o Four 32-bit Battery Backup Registers for a Total of 16 Bytes
 - o Clock Generator and Power Management Controller
 - o Advanced Interrupt Controller and Debug Unit
 - o Periodic Interval Timer, Watchdog Timer and Real-time Timer
- Reset Controller (RSTC)
 - o Based on a Power-on Reset Cell, Reset Source Identification and Reset Output Control
- Clock Generator (CKGR)
 - o Selectable 32,768 Hz Low-power Oscillator or Internal Low Power RC Oscillator on Battery Backup Power Supply, Providing a Permanent Slow Clock
 - o 3 to 20 MHz On-chip Oscillator, One up to 240 MHz PLL and One up to 130 MHz PLL
- Power Management Controller (PMC)
 - o Very Slow Clock Operating Mode, Software Programmable Power Optimization Capabilities
 - o Two Programmable External Clock Signals
- Advanced Interrupt Controller (AIC)
 - o Individually Maskable, Eight-level Priority, Vectored Interrupt Sources
 - o Three External Interrupt Sources and One Fast Interrupt Source, Spurious Interrupt Protected
- Debug Unit (DBGU)
 - o 2-wire UART and Support for Debug Communication Channel, Programmable ICE Access Prevention
- Periodic Interval Timer (PIT)
 - o 20-bit Interval Timer plus 12-bit Interval Counter
- Watchdog Timer (WDT)
 - o Key-protected, Programmable Only Once, Windowed 16-bit Counter Running at Slow Clock
- Real-time Timer (RTT)
 - o 32-bit Free-running Backup Counter Running at Slow Clock with 16-bit Prescaler

- One 4-channel 10-bit Analog-to-Digital Converter
- Three 32-bit Parallel Input/Output Controllers (PIOA, PIOB, PIOC)
 - o 96 Programmable I/O Lines Multiplexed with up to Two Peripheral I/Os
 - o Input Change Interrupt Capability on Each I/O Line
 - o Individually Programmable Open-drain, Pull-up Resistor and Synchronous Output
 - o – High-current Drive I/O Lines, Up to 16 mA Each
- Peripheral DMA Controller Channels (PDC)
- One Two-slot MultiMedia Card Interface (MCI)
 - o SDCard/SDIO and MultiMediaCard™ Compliant
 - o Automatic Protocol Control and Fast Automatic Data Transfers with PDC
- One Synchronous Serial Controller (SSC)
 - o Independent Clock and Frame Sync Signals for Each Receiver and Transmitter
 - o I²S Analog Interface Support, Time Division Multiplex Support
 - o High-speed Continuous Data Stream Capabilities with 32-bit Data Transfer
- Four Universal Synchronous/Asynchronous Receiver Transmitters (USART)
 - o Individual Baud Rate Generator, IrDA® Infrared Modulation/Demodulation, Manchester Encoding/Decoding
 - o Support for ISO7816 T0/T1 Smart Card, Hardware Handshaking, RS485 Support
 - o Full Modem Signal Control on USART0
- Two 2-wire UARTs
- Two Master/Slave Serial Peripheral Interfaces (SPI)
 - o 8- to 16-bit Programmable Data Length, Four External Peripheral Chip Selects
 - o Synchronous Communications
- Two Three-channel 16-bit Timer/Counters (TC)
 - o Three External Clock Inputs, Two Multi-purpose I/O Pins per Channel
 - o Double PWM Generation, Capture/Waveform Mode, Up/Down Capability
 - o High-Drive Capability on Outputs TIOA0, TIOA1, TIOA2
- One Two-wire Interface (TWI)
 - o Master, Multi-master and Slave Mode Operation
 - o General Call Supported in Slave Mode
- IEEE® 1149.1 JTAG Boundary Scan on All Digital Pins
- Required Power Supplies:
 - o 1.65V to 1.95V for VDDBU, VDDCORE and VDDPLL
 - o 1.65V to 3.6V for VDDIOP1 (Peripheral I/Os)
 - o 3.0V to 3.6V for VDDIOP0 and VDDANA (Analog-to-digital Converter)
 - o Programmable 1.65V to 1.95V or 3.0V to 3.6V for VDDIOM (Memory I/Os)

MEMORY MAP:

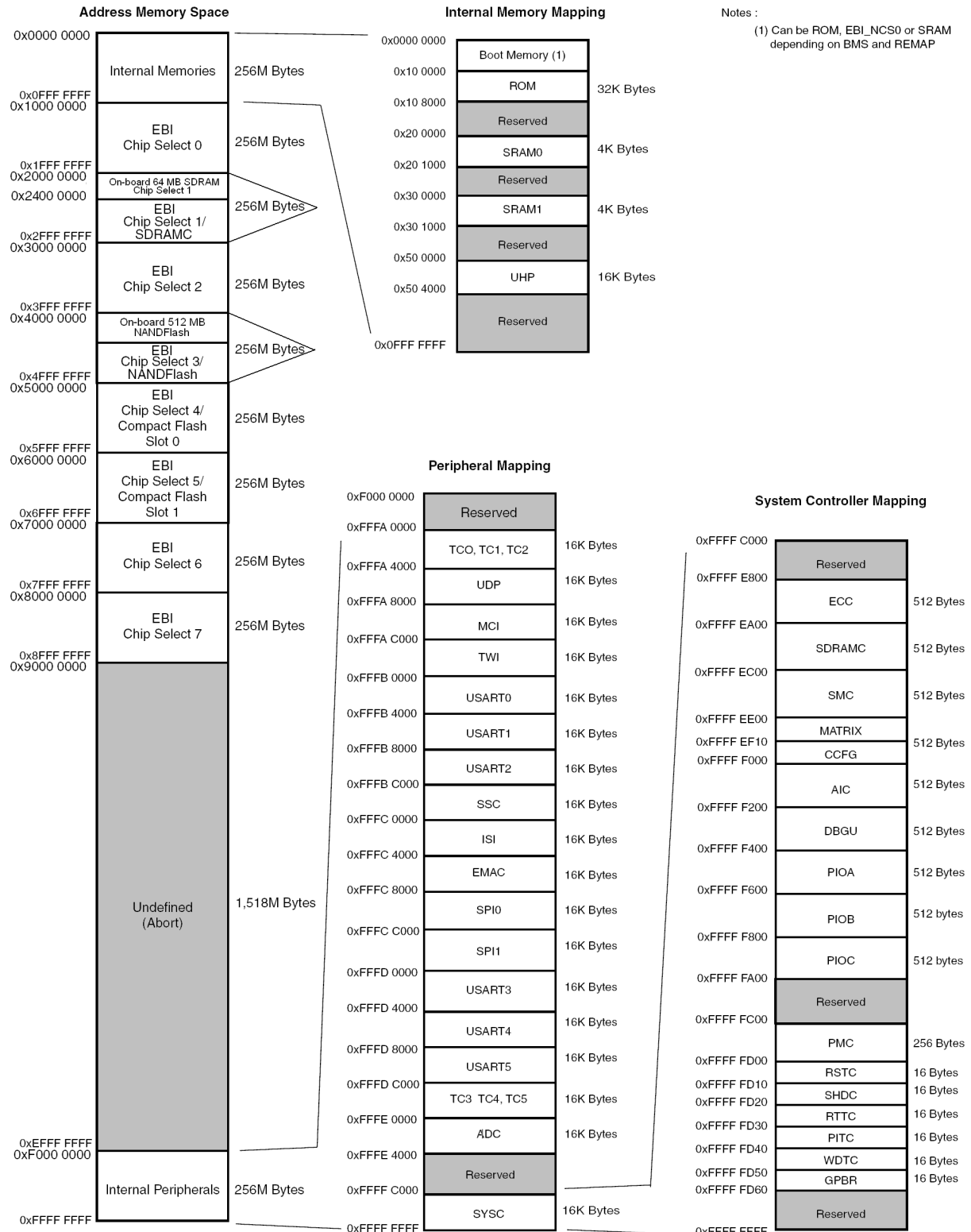

POWER SUPPLY CIRCUIT:

The power supply for SAM9-L9260 must be regulated +5VDC. Please apply exactly 5V as the same power line goes to USB hosts and if you apply over 5V you will damage your USB devices attached to the host.

The current consumption is typical 250mA with 180 MHz clock of SAM9260 and 90MHz clock of external bus.

For the RTC there is a battery backup power supply from a small 3V Li battery type CR2032.

RESET CIRCUIT:

SAM9-L9260 reset circuit is made with a 4.7k pull-up resistor and a RST button connected to GND.

CLOCK CIRCUIT:

Quartz crystal Q1-18.432Mhz is connected to SAM9-L9260 Xin and Xout pins.

Quartz crystal Q2-32768Hz is connected to SAM9-L9260 Xin32 and Xout32 pins.

JUMPER DESCRIPTION:

SMD jumper description

3.3V_E Enable the main 3.3V regulator VR1(3.3V)-RC1587

Default state - closed



3.3V_MCU_E Enable 3.3V to the SAM9260 microcontroller.

Default state - closed



1.8V_MCU_E Enable 1.8V to the SAM9260 microcontroller.

Default state - closed



BDS_E Boundary Scan Enable. The BDS_E jumper is used to select the JTAG boundary scan when JTAGSEL pin asserted at a high level (tied to VDDBU). This pin integrates a permanent pull-down resistor of about 15KΩ to GNDBU. When BDS_E is open JTAG function is selected.

Default state - open



TCK-RTCK Connects RTCK and TCK pins of SAM9260.

Default state open



WPE Connects PC4(pin62) to Write Protection pin of SD/MMC socket. If WP function is not used, WPE jumper has to be open and PC4 is available of EXT connector pin 20.

Default state - closed



CPE Connects PC8(pin61) to Card Present pin of SD/MMC socket. If CP function is not used, CPE jumper has to be open and PC8 is available of EXT connector pin 14.

Default state - closed 

NTRST_E When the NTRST_E jumper is closed – connects NTRST(pin 35) to JTAG connector (pin3).

Default state - closed 

WP_SFLASH_E When the WriteProtect_SerialFLASH_Enable jumper is closed it allows to protect the boot code written to U5(AT45DB161D-SU) flash memory.

Default state open 

WP_NFLASH_E When the WriteProtect_NandFLASH_Enable jumper is closed user can't write in the NAND flash.

Default state open 

A2_L/A2_H Connects Address2(A2)pin of U8-24LC256 memory (default not mounted) to logical 0 or logical 1, i.e. A2_L/A2_H define the memory address of I2C bus.

Default state - open

PTH jumper description:

BMS_LOW Boot Mode Select _ LOW jumper select the boot memory External memory or embedded ROM. When BMS_LOW is closed – BMS pin is logical 0, otherwise – logical 1.

Address	REMAP = 0		REMAP = 1
	BMS = 1	BMS = 0	
0x0000 0000	ROM	EBI_NCS0	SRAM0 4K

Default state - open

BMS_LOW



BAT/EXT The BATerry/EXTernal jumper defines the power source which supplies the backup logic from VDDDBU - pin 47.

BAT position – 3V Li battery type CR2032 plugged in BAT holder supplies VDDDBU through backup VR3(1.8V) MCP1700T-1802E/MB voltage regulator.

EXT position – The VDDDBU is powered from main 1.8V voltage regulator VR2(1.8V) – LM1117.

Default state

BAT/EXT



INTRC/EXTCLK

The INTRC/EXTCLK jumper defines the SAM9260 slow clock source.

INTRC position – internal RC slow clock oscillator is selected

EXTCLK position – external 32768 crystal is used for SAM9260 slow clock.

Default state

INTRC/EXTCLK



RXD1/DRXD

The RXD1/DRXD jumper defines which pin - RXD1 or DRXD - is connected to the RS232 driver (ST3232), i.e. the board allows communication with PC COM port through RXD1 or DRXD.

RXD1 position - RXD1 function of SAM9260 pin 18 is tied to pin12(R1OUT) of U6(ST3232).

DRXD position - DRXD function of SAM9260 pin 21 is tied to pin12(R1OUT) of U6(ST3232).

Default state

RXD1/DRXD



TXD1/DTXD

The TXD1/DTXD jumper defines which pin - TXD1 or DTXD - is connected to RS232 driver (ST3232), i.e. the board allows communication with PC COM port through TXD1 or DTXD.

TXD1 position - TXD1 function of SAM9260 pin 17 is tied to pin11(T1IN) of U6(ST3232).

DTXD position - DTXD function of SAM9260 pin 22 is tied to pin11(T1IN) of U6(ST3232).

Default state

TXD1/DTXD



PHY_PDE/PHY_PDCTRL

PHY_PDE position - The PHY chip U7(KS8721BL) enter to power down mode.

PHY_PDCTRL position - The PHY chip power down mode is controlled from SAM9260 PC1(pin58).

OPEN position - The PHY chip is always enabled.

Default state- open

PHY_PDE/PHY_PDCTRL



NANDF_E

The NANDFlash_Enable allows PC14/NAND_CS pin of SAM9260 to control CE pin of NAND FLASH memory U3(K9F4G08UXM). If the board has to boot from NAND flash the NANDF_E jumper must be closed.

Default state- close

NANDF_E



DF_E

The DataFlash_Enable allows PC11/SPI0_NPCS1 pin of SAM9260 to control CS pin of serial Data Flash memory U5(AT45DB161D-SU). If the board has to boot from Data Flash the DF_E jumper must be closed.

Default state- close

DF_E

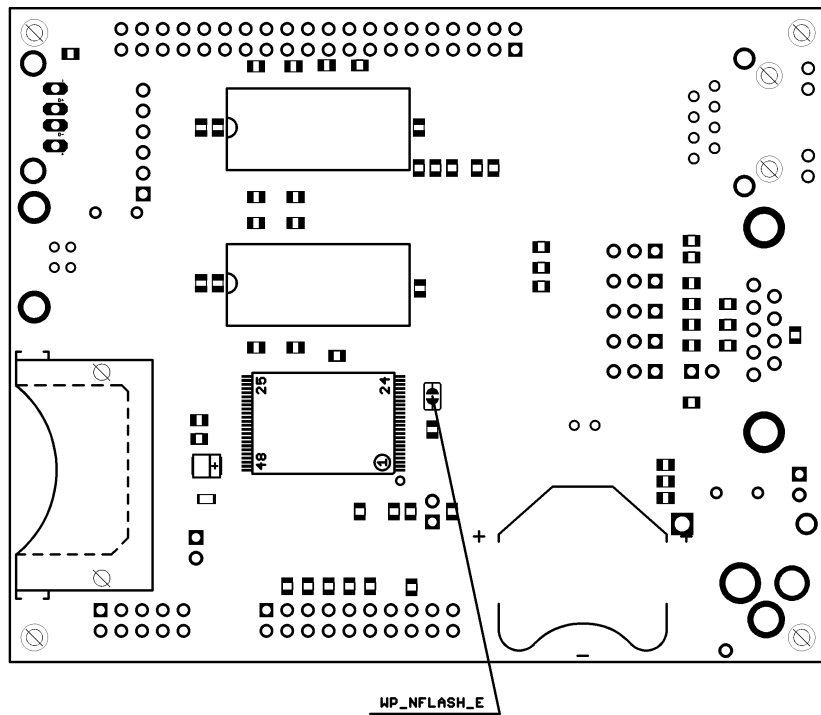
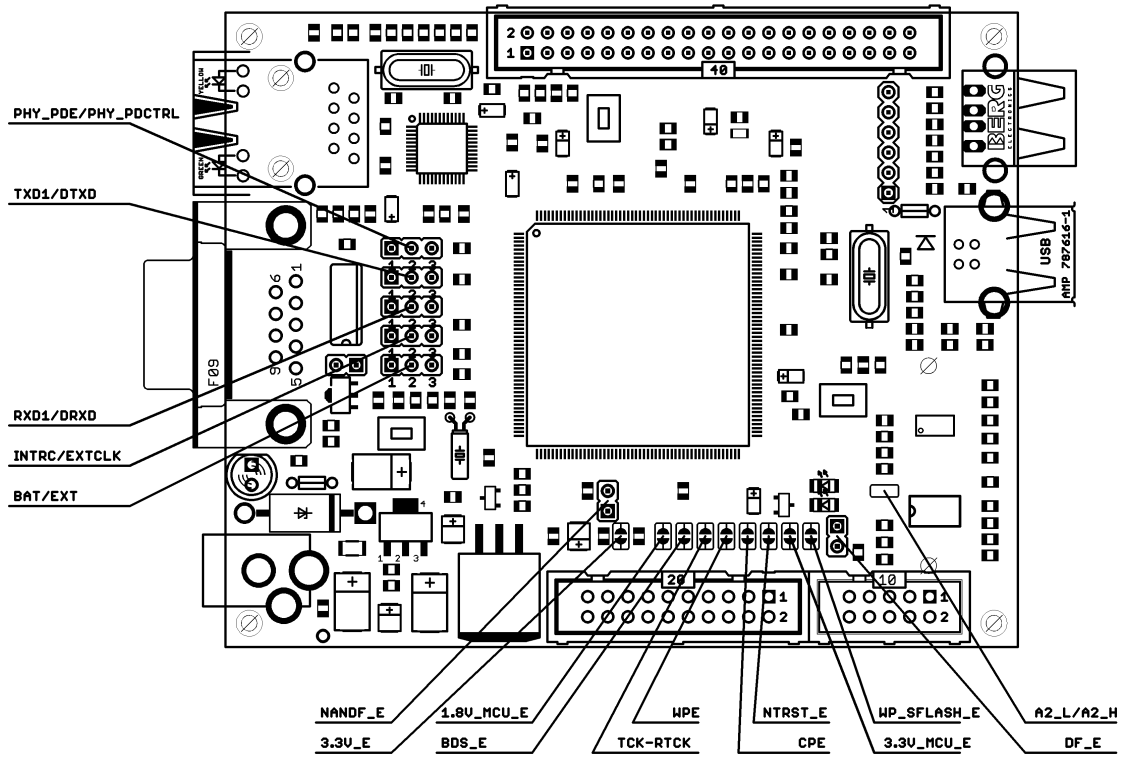

INPUT/OUTPUT:

RS232_0 is used as terminal in Linux, so you can connect to PC hyperterminal for instance and work at command prompt.

The cable between SAM9-L9260 and PC must be female – female, null modem type. Terminal settings are 115200 , 8bits, 1stop, no parity, no flow control.

User button with name **BUT** – connected to SAM9260 pin127 PC15(IRQ1);

Status green LED with name **STAT** (SAM9260 pin185 PA6). The default Linux installation ties it to NAND activity and lights it up whenever NAND is accessed.

Power supply yellow LED with name **PWR_LED** indicates the state of SAM9260. The default Linux installation links it to the CPU load and is blinking it with a distinctive heartbeat pattern.

The LED **PWR_5V** (red) indicates +5V present on the board when it's on.

EXTERNAL CONNECTOR DESCRIPTION:

JTAG:

The JTAG connector allows a software debugger to talk via a JTAG (Joint Test Action Group) port directly to the core. Instructions may be inserted and executed by the core thus allowing SAM9260 memory to be programmed with code and executed step by step by the host software.

For more details refer to IEEE Standard 1149.1 - 1990 Standard Test Access Port and Boundary Scan Architecture and SAM9260 datasheets and users manual.

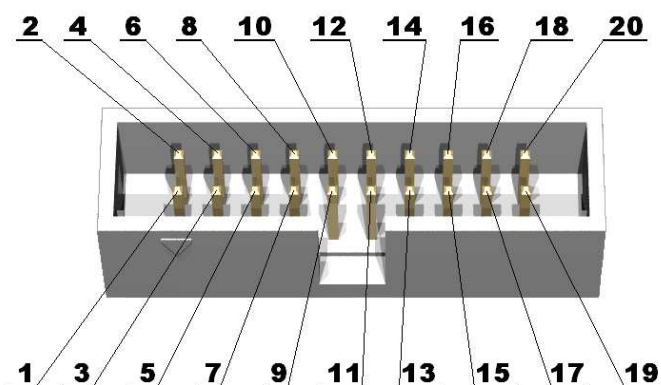

Pin #	Signal Name	Pin #	Signal Name
1	VCC	2	VCC
3	ICE_NTRST	4	GND

5	TDI	6	GND
7	TMS	8	GND
9	TCK	10	GND
11	RTCK	12	GND
13	TDO	14	GND
15	ICE_NIRST	16	GND
17	NC	18	GND
19	NC	20	GND

UEXT

Pin #	Signal Name
1	VCC
2	GND
3	PB8
4	PB9
5	PA24_TWCK
6	PA23_TWD
7	PB0(SPI1_MISO)
8	PB1(SPI1_MOSI)
9	PB2(SPI1_SPCK)
10	PB3(SPI1_NPCS0)

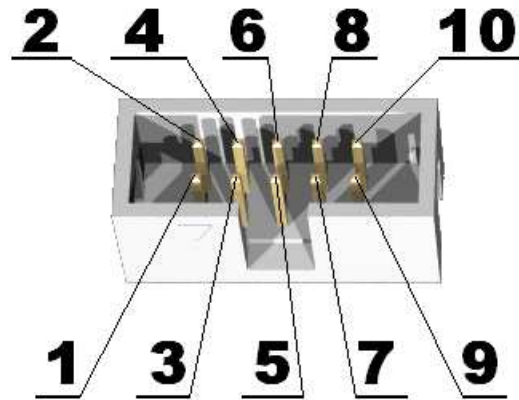

USB D:

Pin #	Signal Name
1	+5V
2	USBDM
3	USBDP
4	GND

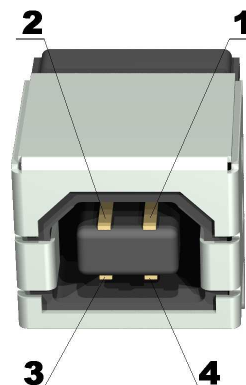

USB A:

Pin #	Signal Name
1	+5V
2	HDMA
3	HDPA
4	GND

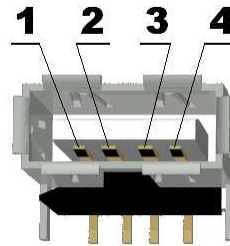

LAN:

Pin #	Signal Name
1	TD+
2	TD-
3	RD+
4	GND_LAN
5	GND_LAN
6	RD-
7	GND_LAN
8	GND_LAN

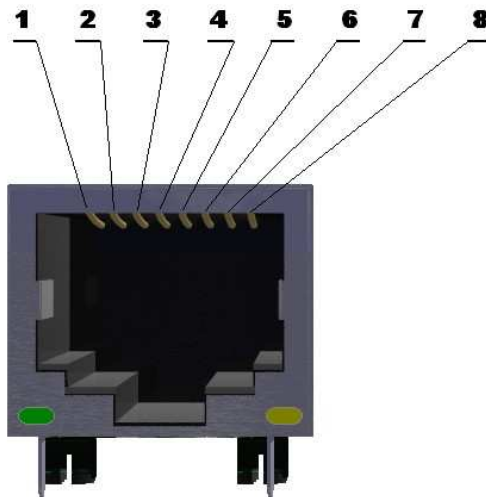

LED	Color	Usage
Right	Yellow	Activity
Left	Green	100MBits/s (Half/Full duplex)

EXT:

SAM9-L9260 has an ext_connector with 40 pins

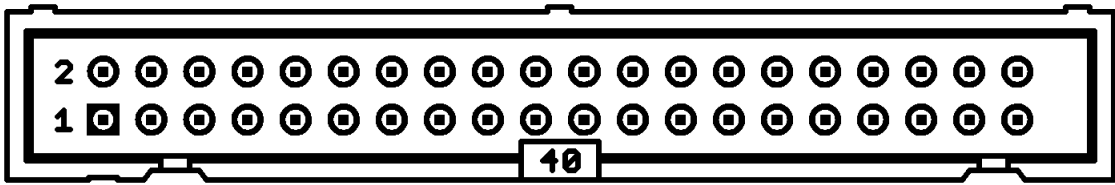

Pin #	Signal Name	Pin #	Signal Name
1	3.3V	2	3.3V
3	PC15	4	+5V
5	PB0	6	PC14_NANDCS
7	PB1	8	PC13_RDYBSY
9	PB2	10	PC10
11	PB3	12	PC9
13	PB4	14	PC8
15	PB5	16	PC7
17	PB8	18	PC6
19	PB9	20	PC4
21	PB10	22	PB31
23	PB11	24	PB30
25	PB16	26	PB29_CTS1
27	PB17	28	PB28_RST1
29	PB18	30	PB27
31	PB19	32	PB26
33	PB20	34	PB25
35	PB21	36	PB24
37	PB22	38	PB23
39	GND	40	GND

RS232:

Pin #	Signal Name
1	NC
2	RXD
3	TXD
4	6
5	GND
6	4
7	RTS
8	CTS
9	NC

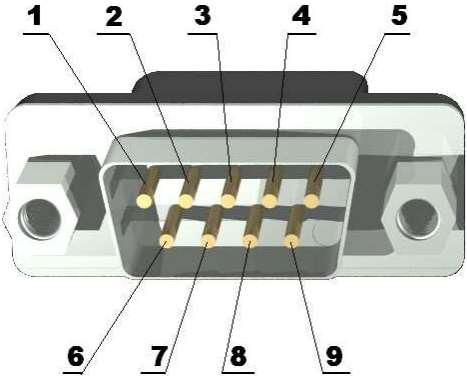

SOFTWARE development:

Overview

The board comes with Linux preloaded in the NAND and DATAFLASH flash memories. It's based on a custom-built kernel and a Debian 5.0 userland. To use it, connect a null-modem cable to the board and to a serial port on your computer, start a terminal program (e.g. HyperTerminal on Windows, minicom on Unix systems) and configure it to use a 115200 baud rate, 8 data bits, 1 stop bit and no parity and no flow control. Then apply power to the board (use a 5VDC regulated power supply with at least 500mA output current) and you should see the board start-up messages. The default root password is 'olimex'.

Restoring the default bootloader and kernel

If for some reason you need to restore the default factory configuration of the board, the procedure is as follows:

First install the ATMEL AT91-ISP v1.12 package which comes on the disk. Reboot the computer if needed.

Remove the NANDF_E and DF_E jumpers on the SAM9-L9260 board and power it up. Connect an USB cable to the USB_D connector on the board and wait for the board to be detected (the driver should already be installed by the AT91-ISP v1.12 package, so let Windows search for it).

Close the NANDF_E and DF_E jumpers and run the *at91sam9260_demo_linux_dataflash.bat* file from the sam9-19260-samba directory. After a while the log file will be displayed and the system should be restored to the default state.

WARNING! This procedure erases the whole NAND flash and the root filesystem will also be destroyed and reset to its factory defaults in the process.

After a successful script execution the bootloaders and the Linux uImage will be placed in DATAFLASH and the root filesystem will be placed in NANDFLASH. The reason to boot from DATAFLASH is an AT91SAM9260 chip errata issue.

Alternative on-board root filesystem restore procedure

Boot-up the board with an alternate root filesystem (e.g. a USB flash drive, NFS exported filesystem...) and use the following command (assuming that the rootjffs2.img file is available in.)

```
sam9-19260:~# flash_eraseall -j /dev/mtd1  
sam9-19260:~# nandwrite -a /dev/mtd1 /rootjffs2.img
```

You may get some errors about bad blocks not being erased - this is normal and is related to the principle of operation of NAND flashes. After the process is completed, reboot the board.

Running with another root filesystem

You may choose to use another media for the root filesystem for various reasons - more capacity, faster access, etc. A complete root tree is archived in the sources/sam9-19260-rootfs.tar.bz2 file. It can be extracted to an empty ext3 partition on an USB drive or to some NFS exported directory. Then you need to tell the kernel where to find the root - this is

accomplished by interrupting the u-boot process at the "Hit any key to stop autoboot:..." prompt and setting the bootargs variable. For example, to boot from a USB flash drive, the command is:

```
U-Boot> setenv bootargs mem=64M console=ttyS0,115200 root=/dev/sda1 rootdelay=10
```

and for booting from an NFS server at address 192.168.0.75:

```
U-Boot> setenv bootargs mem=64M console=ttyS0,115200 root=/dev/nfs
nfsroot=192.168.0.75:nfsroot,proto=tcp ip=192.168.0.222:192.168.0.75
```

Toolchain

The sources for the bootloaders and the Linux kernel must be compiled under Linux PC host. We don't intend to support Cygwin.

The projects were compiled using Codesourcery G++ lite 2009q1, freely available from <http://www.codesourcery.com>. A convenience tarball is provided that contains the Codesourcery binaries along with some useful shell scripts. This tarball must be extracted in user's home directory. Example:

```
cd $HOME
tar xjf codesourcery-toolchain-2009q1-repack.tar.bz2
```

The latter will create a directory

```
$HOME/bin/codesourcery-armgcc-2009q1
```

Along with some shell scripts that must be sourced before compilation:

```
$HOME/bin/linux_cross_compile.sourceme
$HOME/bin/bootloader_cross_compile.sourceme
```

The latter shell scripts would add the cross compiler binaries to the PATH environment variable and will set the ARCH and CROSS_COMPILE variables to *arm* and *arm-none-linux-gnueabi-/arm-none-eabi-* respectively.

Building a custom kernel

The recommended build method is to use a cross-compiler. Building natively should also work but would be very time-consuming. At the moment of this writing, the current kernel version is 2.6.31-rc3, for which a pre-patched tarball is provided. After extracting the sources in a temporary directory you can build the default kernel by typing

```
$ source $HOME/bin/linux_cross_compile.sourceme
$ make sam9_19260_defconfig
$ make uImage
```

After the compilation, the kernel should be available at *arch/arm/boot/uImage*. If the build process fails to detect the *mkimage* program then you need to get it and put it in your PATH. The easiest way is to compile U-Boot and fetch it from the *u-boot/tools* subdirectory. The new kernel can be transferred to the board by various means - e.g. use the board restoration process and change the kernel in there, tftpboot-ing the board, etc.

Convenience GIT patches for the kernel are also provided in a separate tarball.

Building the bootstrap binary

Extract the sources from source/at91bootstrap-2.4-olimex.tar.bz2 to your working directory and issue the following commands:

```
$ source $HOME/bin/bootloader_cross_compile.sourceme
$ make sam9_l9260_defconfig
```

If everything is correct, the resulting binary file will be located in the /binaries directory.

Building U-Boot

Extract the sources from source/u-boot-olimex-git20090716.tar.bz2 and issue:

```
$ source $HOME/bin/bootloader_cross_compile.sourceme
$ make sam9l9260_config
$ make
```

Cross-compiling a simple "hello world" example

Extract one of the provided cross-compilers on your host system and add it to the PATH variable. Use the cross-compiler to build the example, then transfer it to the board by e.g. USB flash drive, http download etc.

Example commands:

----- On the host system -----

```
$ source $HOME/bin/linux_cross_compile.sourceme
```

```
$ cat > hello.c
```

```
#include <stdio.h>
```

```
int main(void)
```

```
{
```

```
    unsigned int i;
```

```
    printf("\r\nProba proba ");
```

```
    for (i=0; i<10; i++)
```

```
        printf("\r\n%d", i);
```

```
    return 0;
```

```
}
```

```
^D
```

```
$ arm-none-linux-gnueabi-gcc -o hello hello.c
```

```
$ cp hello ~/htdocs/
```

----- On the board -----

```
~ # wget http://192.168.0.xx/hello
```

```
~ # chmod 777 hello
```

```
~ # ./hello
```

```
Proba proba
```

```
0
```

```
1
```

```
....
```

Using JTAG to program the board

A sample project is provided in the "TEST_BUTT" directory that demonstrates how to write a project that runs directly on the core, without the need of an operating system. It was developed using IAR Embedded Workbench for ARM ver. 4.42A with a Segger J-Link JTAG adapter

Common Questions

Q: When booting from the internal NAND flash the board seems to hang at "INIT: version 2.86 booting" and/or "Activating swap...done" lines

A: When mounting the JFFS2 root filesystem, the system performs a consistency check (similar to fsck). This almost blocks all access to the nand flash and the system appears to hang. Please wait - on a first boot of a new filesystem this could take up to 5 minutes and is considered normal.

Q: There are messages "Buffer I/O error on device mtdblock0, logical block 0;end_request: I/O error, dev mtdblock0, sector 0" during boot-up. Is there a problem on the board?

A: These messages indicate incorrect OOB records in the part of the flash where the bootloader is stored and are due to the version of SAM-BA which is used to write the various parts of the bootloader. For all practical reasons the above messages are harmless.

Q: The I/O operations are slow when using the on-board nand flash or USB flash drive.

A: When doing a sequential read/write (e.g. one single large file) flash memories can be fast. When reading/writing many small files the performance will be really low.

Q: How to boot from the on board DataFlash?

A: Make sure that NANDF_E jumper is not connected and DF_E jumper is connected. If the dataflash has been correctly programmed, the board should start up.

Q: Is the SD/MMC card supported?

A: The SD/MMC card is fully supported, including detection of card insertion/removal and write lock

Q: What do the two LED's indicate?

A: These two leds are driven by default by the linux LED driver. The STAT LED is switched on NAND memory access. The PWR_LED LED is blinking with a distinctive heartbeat pattern and a frequency that depends on the system load.

Q: The system time is lost after reset, how to avoid that?

A: Unfortunately the Linux AT91SAM9 RTC driver is not yet operational. When it is completed, you would just need a standard 3V battery at the socket at the back of the board. Until then please set the date manually or use a network time synchronization utility as ntpdate. Note also that AT91SAM9260 chips have a RomBOOT errata issue where RomBOOT incorrectly resets the RTT on every system reset.

Acknowledgements:

The kernel used is based on Linux-2.6.31-rc3

The root filesystem is a debian lenny distribution

The bootstrap loader is based on the at91bootstrap-2.4 package, provided by ATMEL at <http://www.at91.com>

The u-boot bootloader is based on a GIT checkout from <http://git.denx.de/u-boot>

The cross-compilers are available from <http://www.codesourcery.com>

All of the above packages are distributed under the GPL and/or another free license (e.g. BSD license).

ORDER CODE:

SAM9-L9260 – assembled and tested (no kit, no soldering required)

How to order?

You can order to us directly or by any of our distributors.

Check our web www.olimex.com/dev for more info.



All boards produced by Olimex are RoHS compliant

Software revision history:

- REV.A - created April 2008
- REV.B - created September 2008
 - moved bootloaders and Linux kernel image to DATAFLASH because of SAM9 chip errata
 - switched to codesourcery toolchain
 - updated to Linux version 2.6.26.3
 - updated to u-boot-1.3.4-git
 - moved NAND flash root image writing into the SAM-BA script
- REV.C - created July 2009
 - updated to Linux version 2.6.31-rc3
 - updated to Debian Lenny ARMEL distribution
 - updated to latest GIT checkout of u-boot (2009.06-00374-g3427faf)

Hardware revision:

- Rev. B - created June 2008

Disclaimer:

© 2009 Olimex Ltd. All rights reserved. Olimex®, logo and combinations thereof, are registered trademarks of Olimex Ltd. Other terms and product names may be trademarks of others.

The information in this document is provided in connection with Olimex products. No license, express or implied or otherwise, to any intellectual property right is granted by this document or in connection with the sale of Olimex products.

Neither the whole nor any part of the information contained in or the product described in this document may be adapted or reproduced in any material from except with the prior written permission of the copyright holder.

The product described in this document is subject to continuous development and improvements. All particulars of the product and its use contained in this document are given by OLIMEX in good faith. However all warranties implied or expressed including but not limited to implied warranties of merchantability or fitness for purpose are excluded.

This document is intended only to assist the reader in the use of the product. OLIMEX Ltd. shall not be liable for any loss or damage arising from the use of any information in this document or any error or omission in such information or any incorrect use of the product.