

LPC-MT-2138 development board

Users Manual



All boards produced by Olimex are ROHS compliant

Rev. Initial, September 2005

Copyright(c) 2010, OLIMEX Ltd, All rights reserved

INTRODUCTION

LPC-MT-2138 is small terminal board which uses LPC2138 microcontroller. With its LCD, relay, five buttons, variety of interfaces such as RS232, JTAG, I2C, Dallas and extension connector for some of the microcontroller's pins this board is suitable for different embedded systems applications.

BOARD FEATURES

- Microcontroller: **LPC2138** 16/32 bit ARM7TDMI-S with 512K Bytes Program Flash, 32K Bytes RAM, RTC, 8x 10 bit ADC 2.44 uS, 2x UARTs, I2C, SPI, 2x 32bit TIMERS, 8x CCR, 6x PWM, WDT, 5V tolerant I/O, up to 60MHz operation
- JTAG connector as per ARM's 2x10 pin layout, ARM-JTAG (Wiggler) compatible
- 14.7456 Mhz crystal on socket, allow easy communication setup (4x PLL = 58,9824 Mhz CPU clock)
- RS232 interface circuit with SUB-D 9 pin connector
- LCD16x2 display with BACKLIGHT
- five buttons
- Dallas iButton port
- Frequency input
- Relay with 10A/250VAC contacts
- Buzzer
- Status LED
- RESET circuit
- RESET button
- Bootloader enable jumper and pullup
- DEBUG jumper for JTAG enable/disable
- RTCK pullup resistors
- Power plug-in jack
- power supply: 9VAC/+12VDC
- three on board voltage regulators 1.8V, 3.3V and 5V
- power supply filtering capacitor
- Four mounting holes
- PCB: FR-4, 1.5 mm (0,062"), soldermask, white silkscreen component print
- Dimensions: 120x38 mm (4.75x1.5")

ELECTROSTATIC WARNING

The LPC-MT-2138 board is shipped in protective anti-static packaging. The board must not be subject to high electrostatic potentials. General practice for working with static sensitive devices should be applied when working with this board.

BOARD USE REQUIREMENTS

Cables: Depends on the used programming/debugging tool. It could be 1.8 meter USB A-B cable to connect [ARM-JTAG-EW](#), [ARM-USB-OCD](#), [ARM-USB-TINY](#) and [ARM-USB-TINY-H](#) to USB host on PC or LPT cable in case of [ARM-JTAG](#) or other programming/debugging tools. You will need a serial cable if not for programming, than for configuring the board.

Hardware: Programmer/Debugger – some of Olimex programmers are applicable, for example [ARM-JTAG](#), [ARM-JTAG-EW](#), [ARM-USB-OCD](#), [ARM-USB-TINY](#), [ARM-USB-TINY-H](#) or other compatible programming/debugging tool.

PROCESSOR FEATURES

LPC-MT-2138 board use LPC2138 microcontroller based on a 16/32-bit ARM7TDMI-S CPU with real-time emulation and embedded trace support, that combine the microcontroller with 512 kB of embedded high-speed flash memory. A 128-bit wide memory interface and a unique accelerator architecture enable 32-bit code execution at maximum clock rate. with these features:

- 32 kB of on-chip static RAM and 256/512 kB of on-chip flash program memory. 128-bit wide interface/accelerator enables high-speed 60 MHz operation.
- In-System Programming/In-Application Programming (ISP/IAP) via on-chip bootloader software. Single flash sector or full chip erase in 400 ms and programming of 256 B in 1 ms.
- EmbeddedICE RT and Embedded Trace interfaces offer real-time debugging with the on-chip RealMonitor software and high-speed tracing of instruction execution.
- Two 8-channel 10-bit ADCs provide a total of up to 16 analog inputs, with conversion times as low as 2.44 ms per channel.
- Single 10-bit DAC provides variable analog output.
- Two 32-bit timers/external event counters (with four capture and four compare channels each), PWM unit (six outputs) and watchdog.
- Low power Real-time clock with independent power and dedicated 32 kHz clock input.
- Multiple serial interfaces including two UARTs (16C550), two Fast I²C-bus (400 kbit/s), SPI and SSP with buffering and variable data length capabilities.
- Vectored interrupt controller with configurable priorities and vector addresses.
- Up to forty-seven 5 V tolerant general purpose I/O pins
- Up to nine edge or level sensitive external interrupt pins available.
- 60 MHz maximum CPU clock available from programmable on-chip PLL with settling time of 100 ms.

- On-chip integrated oscillator operates with external crystal in range of 1 MHz to 30 MHz and with external oscillator up to 50 MHz.
- Power saving modes include Idle and Power-down.
- Individual enable/disable of peripheral functions as well as peripheral clock scaling down for additional power optimization.
- Processor wake-up from Power-down mode via external interrupt or BOD.
- Single power supply chip with POR and BOD circuits:
 - CPU operating voltage range of 3.0 V to 3.6 V ($3.3 \text{ V} \pm 10 \%$) with 5 V tolerant I/O pads.

BLOCK DIAGRAM

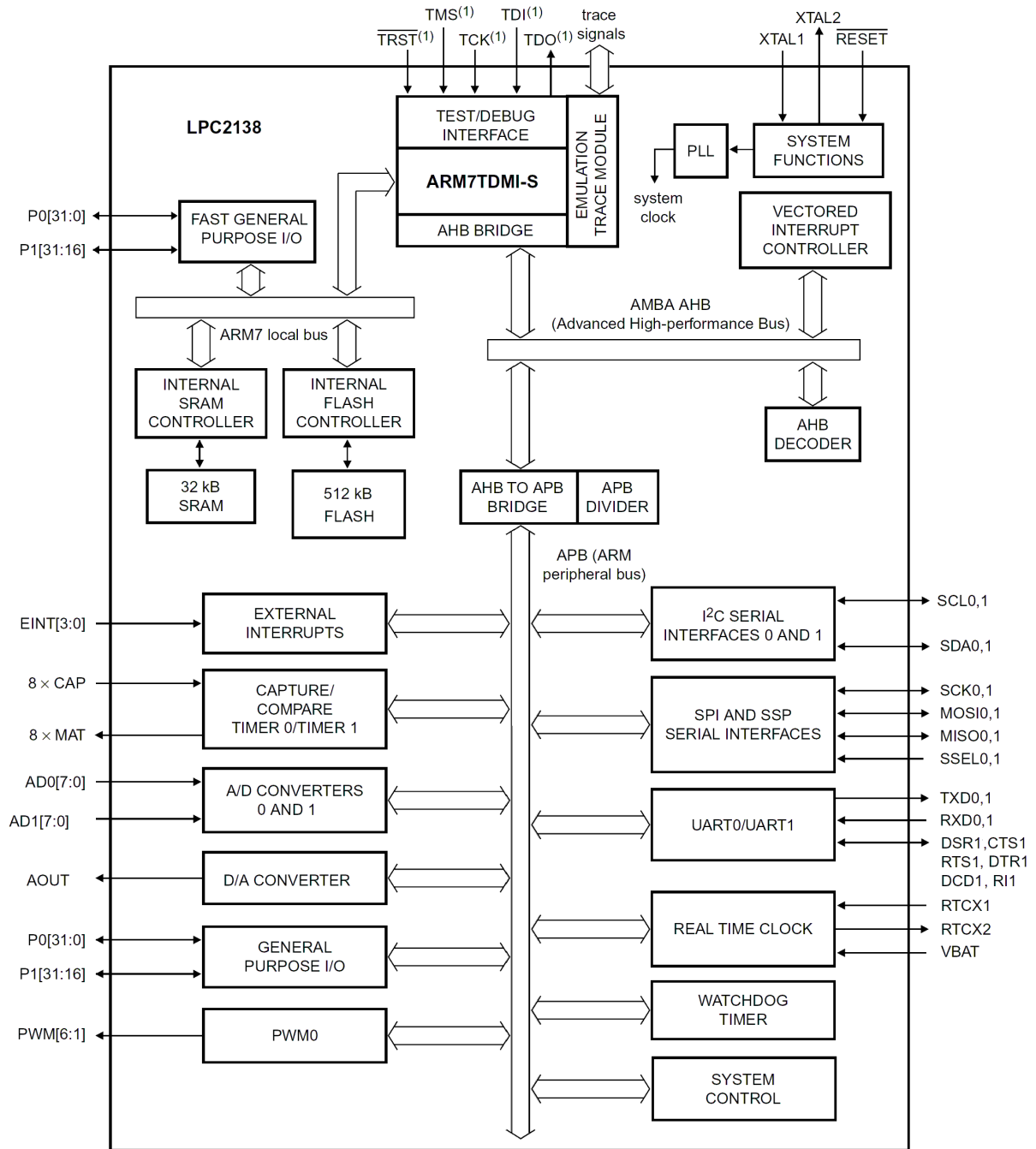

(1) Pins shared with GPIO.

MEMORY MAP

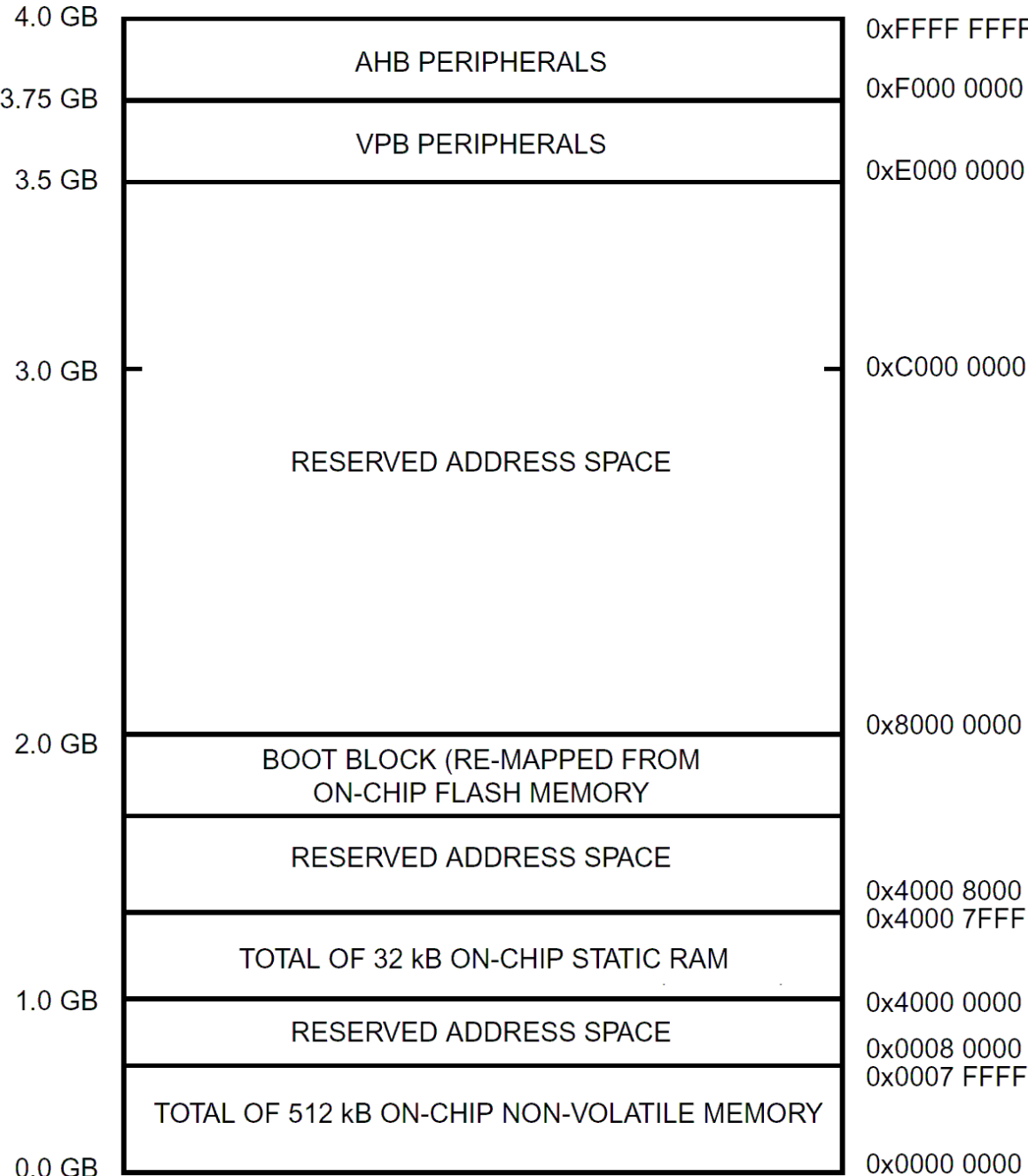

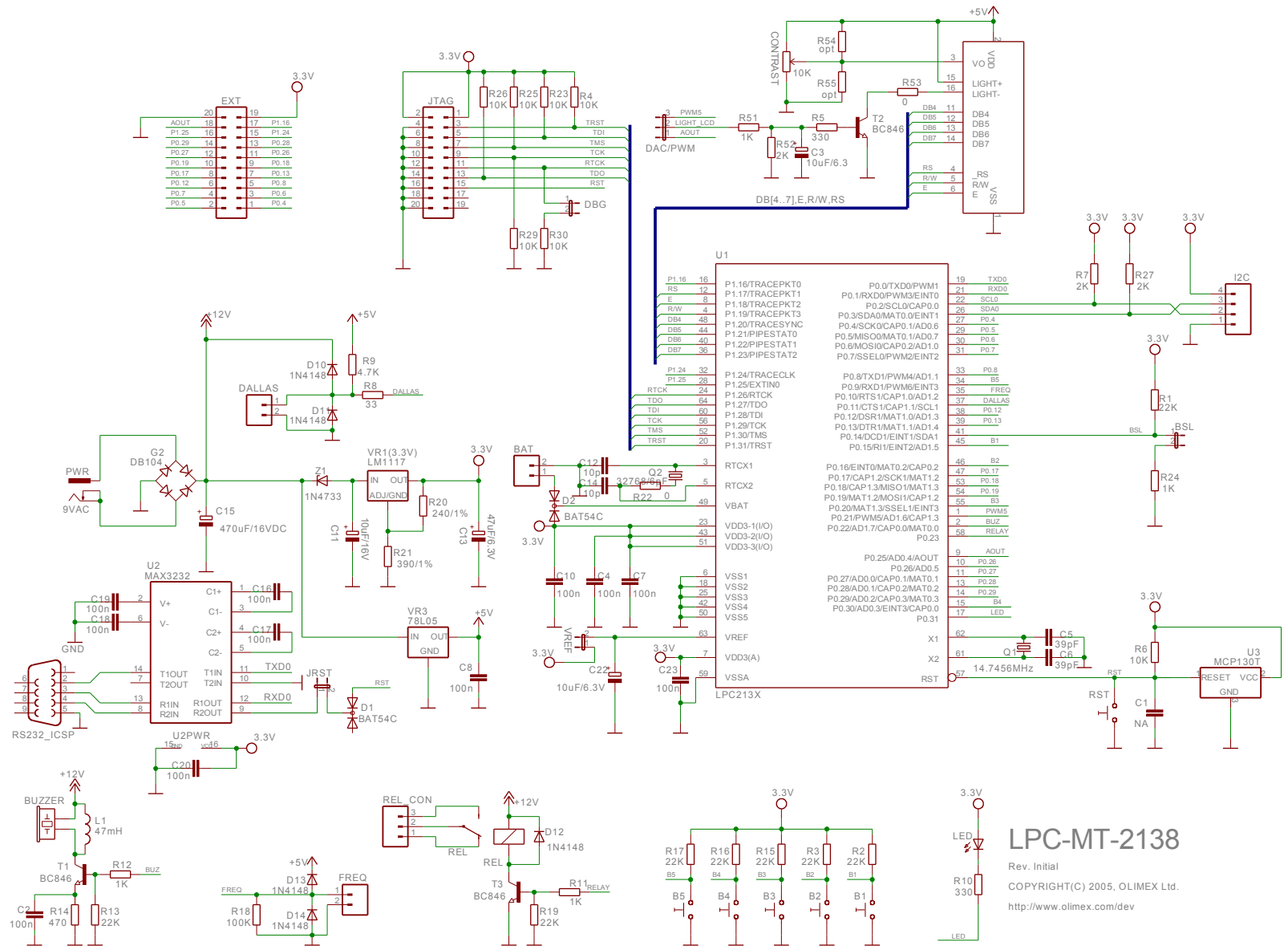

LPC-MT-2138
Rev. Initial
COPYRIGHT(C) 2005, OLIMEX Ltd.
<http://www.olimex.com/dev>

BOARD LAYOUT

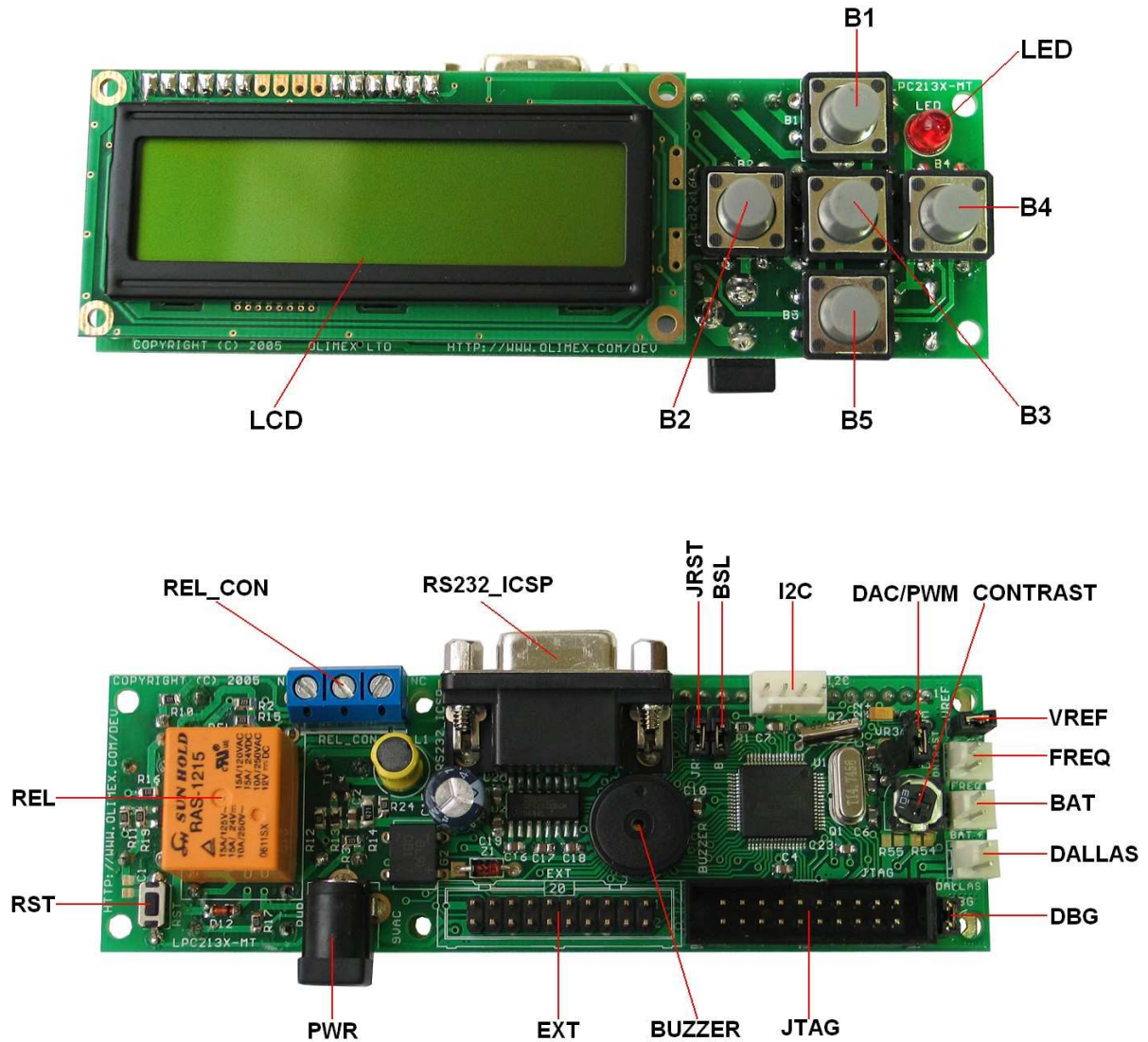

POWER CIRCUIT

LPC-MT-2138 can is typically power supplied with +9VAC or 12VDC from power jack.

RESET CIRCUIT

LPC-MT-2138 reset circuit includes R6 (10k) pull-up, U3 (MCP130T), LPC2138 pin 57 (RST) and RST button.

CLOCK CIRCUIT

Quartz crystal Q1 14.7456 MHz is connected to **LPC2138** pin 61 (X2) and pin 62 (X1). Quartz crystal Q2 32.768 KHz is connected to **LPC2138** pin 3 (RTCX1) and pin 5 (RTCX2).

JUMPER DESCRIPTION

VREF



Connects LPC2138 pin 63 (VREF) to 3.3V.
Default state is closed.

DAC/PWM

When this jumper is in position DAC - connects LIGHT_LCD signal to LPC2138 pin 9 (AOUT); when this jumper is in position PWM - connects LIGHT_LCD signal to LPC2138 pin 1 (PWM5).

Default state is PWM - closed.

JRST



Enables LPC2138 reset via UART.
Default state is open.

BSL



This jumper is connected to LPC2138 pin 41 (P0.14). When this jumper is open, P0.14 is pulled-up to 3.3V via R1 (22k) , when is closed P0.14 is pulled-down via R24 (1k). LOW level on pin P0.14 immediately after reset is considered as an external hardware request to start the ISP command handler. If there is no request for the ISP command handler execution (P0.14 is sampled HIGH after reset), a search is made for a valid user program. If a valid user program is found then the execution control is transferred to it. If a valid user program is not found, the auto-baud routine is invoked.

Default state is open.

DBG



Enables JTAG debug operations.
Default state is closed.

INPUT/OUTPUT

Reset button with name **RST**, connected to LPC2138 pin 57 (RST).

User button with name **B1**, connected to LPC2138 pin 45 (P0.15).

User button with name **B2**, connected to LPC2138 pin 46 (P0.16).

User button with name **B3**, connected to LPC2138 pin 55 (P0.20).

User button with name **B4**, connected to LPC2138 pin 15 (P0.30).

User button with name **B5**, connected to LPC2138 pin 34 (P0.9).

LCD 16x2 display with BACKLIGHT, connected as follows: RS - to LPC2138 pin 12 (P1.17); R/W - to LPC2138 pin 4 (P1.19); E - to LPC2138 pin 8 (P1.18), DB4 - to LPC2138 pin 48 (P1.20), DB5 - to LPC2138 pin 44 (P1.21), DB6 - to LPC2138 pin 40 (P1.22), DB7 to LPC2138 pin 36 (P1.23).

Potentiometer with name **Contrast** for setting LCD contrast voltage.

Status Led with name **LED** connected to LPC2138 pin 17 (P0.31).

Buzzer connected to LPC2138 pin 2 (P0.22).

Relay with name REL connected to LPC2138 pin 58 (P0.23).

EXTERNAL CONNECTORS DESCRIPTION

JTAG

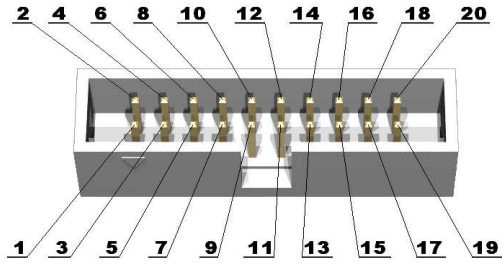

Pin #	Signal Name	Pin #	Signal Name
1	+3.3 V	2	+3.3 V
3	TRST	4	GND
5	TDI	6	GND
7	TMS	8	GND
9	TCK	10	GND
11	RTCK	12	GND
13	TDO	14	GND
15	RST	16	GND
17	Not Connected	18	GND
19	Not Connected	20	GND

I2C

Pin #	Signal Name
1	GND
2	SCL0
3	SDA0
4	3.3V

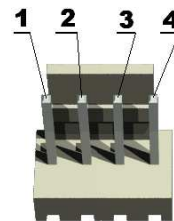

EXT

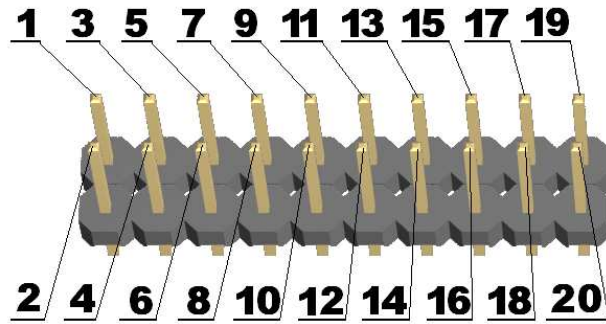

Pin #	Signal Name	Pin #	Signal Name
1	P0.4	2	P0.5
3	P0.6	4	P0.7
5	P0.8	6	P0.12
7	P0.13	8	P0.17
9	P0.18	10	P0.19
11	P0.26	12	P0.27
13	P0.28	14	P0.29
15	P1.24	16	P1.25
17	P1.16	18	AOUT
19	3.3V	20	GND

FREQ

Pin #	Signal Name
1	FREQ(P0.10)
2	GND

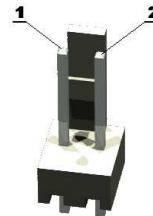

DALLAS

Pin #	Signal Name
1	DALLAS(P0.11)
2	GND

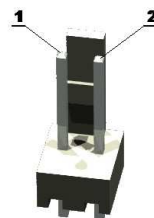

BAT

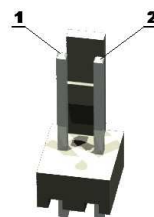

Pin #	Signal Name
1	VBAT
2	GND

RS232/ICSP

Pin #	Signal Name
1	NC
2	T1OUT
3	R1IN
4	R2IN
5	GND
6	NC
7	NC
8	NC
9	NC

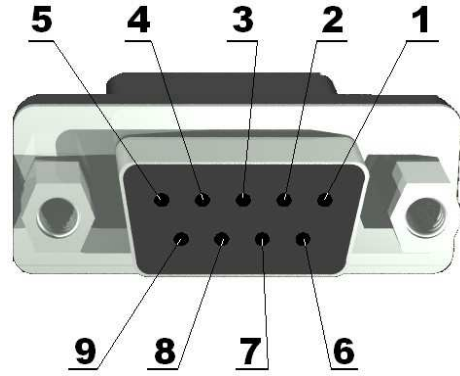

PWR:

Pin #	Signal Name
1	Power Input
2	GND

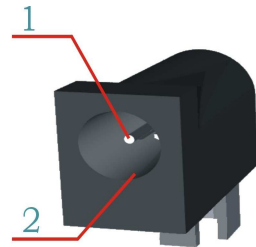

REL CON:



This connector provides the user with access to the contact plates of the relay.

MECHANICAL DIMENSIONS

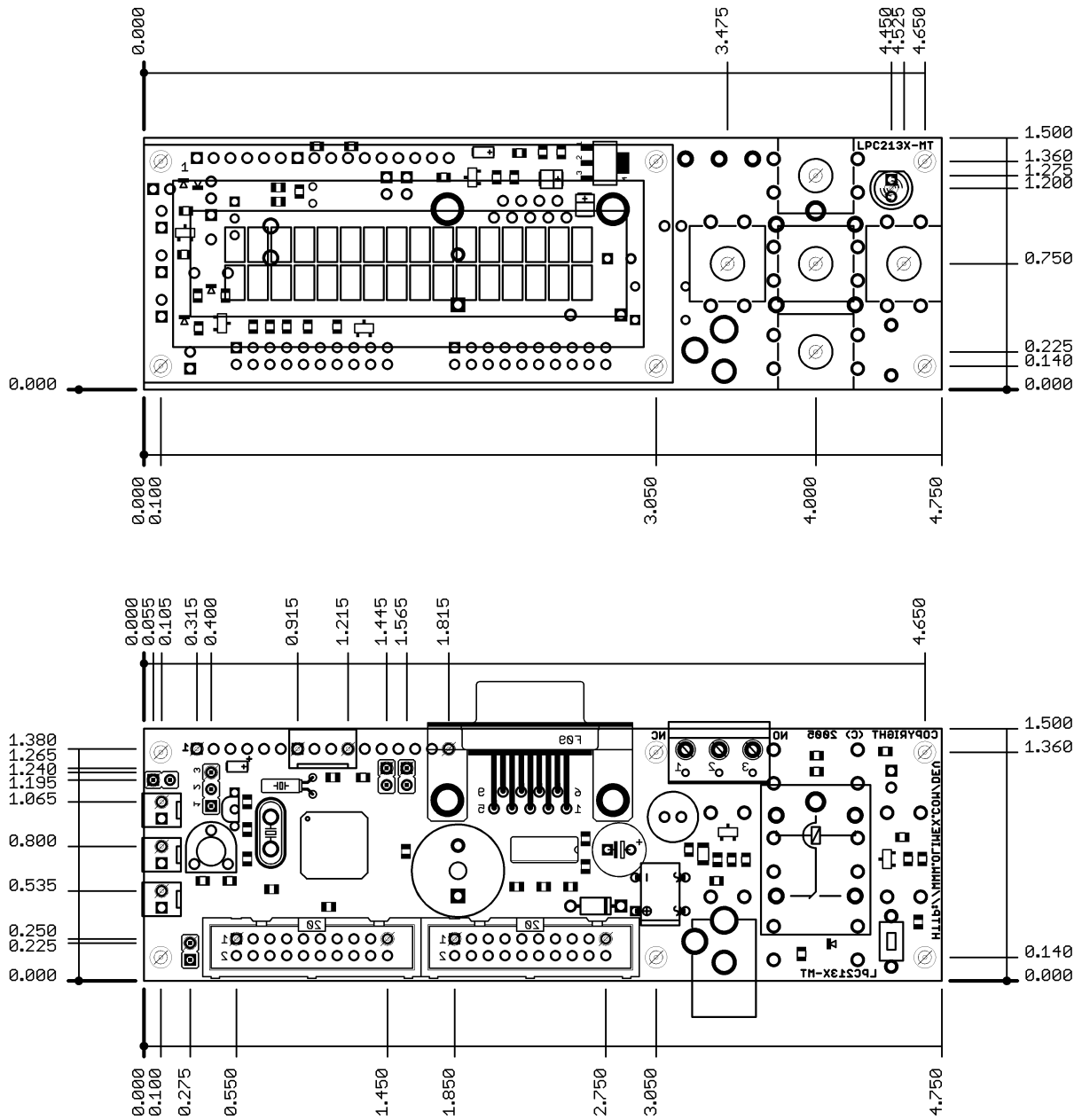

- All measures are in Inches.

AVAILABLE DEMO SOFTWARE

- [LCD drive](#) code (EW-ARM)
- [RTC](#) code (EW-ARM)
- [RS232](#) code (EW-ARM)
- [Button, Relay, LED, buzzer](#) demo code (EW-ARM)
- [LCD, RTC, UART, BUTTONs, BUZZER](#) demo code (GNU) by Markus Dornhofer
- [OpenOCD + Eclipse set of projects 1.00](#) include flash write make file for LPC-MT-2138.

ORDER CODE

LPC-MT-2138 - completely assembled and tested.

How to order?

You can order to us directly or by any of our distributors.

Check our web www.olimex.com/dev for more info.

Revision history:

Rev. Initial - create September 2005

Disclaimer:

© 2010 Olimex Ltd. All rights reserved. Olimex®, logo and combinations thereof, are registered trademarks of Olimex Ltd. Other terms and product names may be trademarks of others.

The information in this document is provided in connection with Olimex products. No license, express or implied or otherwise, to any intellectual property right is granted by this document or in connection with the sale of Olimex products.

Neither the whole nor any part of the information contained in or the product described in this document may be adapted or reproduced in any material form except with the prior written permission of the copyright holder.

The product described in this document is subject to continuous development and improvements. All particulars of the product and its use contained in this document are given by OLIMEX in good faith. However all warranties implied or expressed including but not limited to implied warranties of merchantability or fitness for purpose are excluded.

This document is intended only to assist the reader in the use of the product. OLIMEX Ltd. shall not be liable for any loss or damage arising from the use of any information in this document or any error or omission in such information or any incorrect use of the product.