

## LPC-P2106 PROTOTYPE BOARD FOR LPC2106 ARM7TDMI-S MICROCONTROLLER

### Features:

- MCU: 16/32 bit LPC2106 with 128K Bytes Program Flash, 64K Bytes RAM, RTC, 2x UARTs, I2C, SPI, 2x 32bit TIMERS, 7x CCR, 6x PWM, WDT, 5V tolerant I/O, up to 60MHz operation
- standard JTAG connector with ARM 2x10 pin layout for programming/debugging with ARM-JTAG
- push BUTTON with pullup
- status LED
- two on board voltage regulators 1.8V and 3.3V with up to 800mA current
- Power plug-in jack
- single power supply: +5-9VAC/DC required
- power supply filtering capacitor
- RS232 interface circuit
- RESET circuit
- RESET button
- DEBUG jumper for JTAG enable
- BSL jumper for Bootloader enable
- RTCK pullup resistor
- 14.7456 Mhz crystal allow easy communication setup (4x PLL = 58,9824 Mhz CPU clock)
- extension headers for all uC ports
- PCB: FR-4, 1.5 mm (0,062"), green soldermask, white silkscreen component print
- prototype PCB area with +3.3V and GND bus
- Four mounting holes
- Dimensions: 77x100 mm (3.9x3.05")

### Supported devices:

Philips Semiconductors Inc. LPC2106 16/32 bit ARM7TDMI-S™

### JTAG interface:

The JTAG connector is 2x10 pin with 0,1" step and ARM recommended JTAG layout. PIN.1 is marked with square pad on bottom and arrow on top.

**Note:** to enable JTAG interface DBG jumper should be shorted at the time of POWER UP.

**Important:** when JTAG is enabled P0.18-P1.31 ports take their JTAG alternative function no matter of PINSEL register value, so during

debugging with JTAG these ports are not available for the user program.

### JTAG signals description:

**PIN.1 (VTREF)** Target voltage sense. Used to indicate the target's operating voltage to the debug tool.

**PIN.2 (VTARGET)** Target voltage. May be used to supply power to the debug tool.

**PIN.3 (nTRST)** JTAG TAP reset, this signal should be pulled up to Vcc in target board.

**PIN.4,6, 8, 10,12,14,16,18,20** Ground. The Gnd-Signal-Gnd-Signal strategy implemented on the 20-way connection scheme improves noise immunity on the target connect cable.

**PIN.5 (TDI)** JTAG serial data in, should be pulled up to Vcc on target board.

**PIN.7 (TMS)** JTAG TAP Mode Select, should be pulled up to Vcc on target board.

**PIN.9 (TCK)** JTAG clock.

**PIN.11 (RTCK)** JTAG re-timed clock. Implemented on certain ASIC ARM implementations the host ASIC may need to synchronize external inputs (such as JTAG inputs) with its own internal clock.

**PIN.13 (TDO)** JTAG serial data out.

**PIN.15 (nSRST)** Target system reset.

**PIN.17 (DBGREQ)** Asynchronous debug request. DBGREQ allows an external signal to force the ARM core into debug mode, should be pull down to GND.

**PIN.19 (DBGACK)** Debug acknowledge signal. The ARM core acknowledges debug-mode in response to a DBGREQ input.

### JTAG connector layout:

#### ARM\_JTAG

VREF	1	2	VTARGET
NTRST	3	4	GND
TDI	5	6	GND
TMS	7	8	GND
TCK	9	10	GND
RTCK	11	12	GND
TDO	13	14	GND
RST	15	16	GND
DBGREQ	17	18	GND
DBGACK	19	20	GND

(PCB TOP VIEW)

Copyright(c) 2004, OLIMEX Ltd., All rights reserved.

Development boards for ARM, AVR, MSP430 and PIC microcontrollers <http://www.olimex.com/dev>

### Power supply:

Power supply is made with two LDO adjustable voltage regulators LM1117. Input voltage should be in range 5-9VAC/DC.

**RS232 interface:**

LPC2106 have two RS232 channels. Only Channel 0 is via MAX3232 IC to SUB D 9 pin connector. Channel 0 with TXD0 and RXD0 is used by the Bootloader program to program LPC2106 Flash memory without external programmer. Channel 1 is general purpose RS232 channel and may be used by user program.

**RESET:**

Reset circuit is made by simple external RC group. There is possibility to apply RESET externally by the small RESET pushbutton on the board.

**Oscillator:**

14.7456 Mhz crystal is used for LPC2106 as it allows easy setup on any communication speed This makes programming with Philips ISP utility possible at any speed up to 115Kbps.

**Bootloader:**

The Bootloader program is enabled when BSL jumper is shorted at time of power up. In this case Bootloader takes the program control and user may download Flash memory with Philips ISP programming utility. Note that if you want to run code in Flash memory BSL jumper should be open at time of power up, otherwise Bootloader

will stay in control and will not allow program in Flash to run.

**Board layout:**

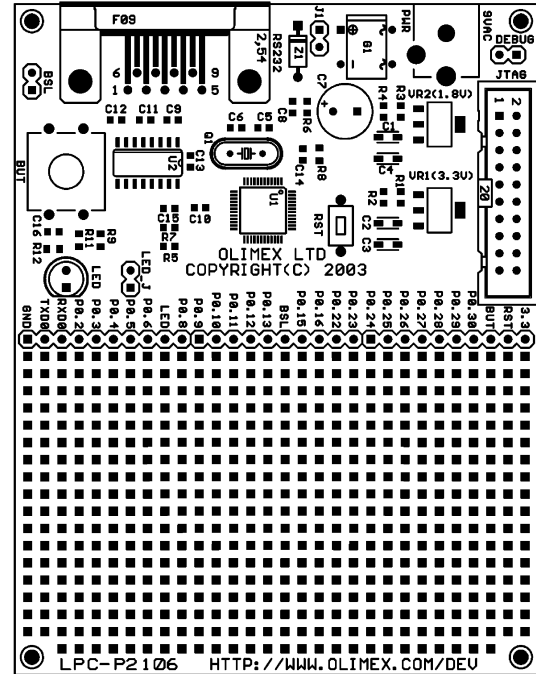

**Ordering codes:**

LPC-P2106 - assembled and tested with LPC2106 microcontroller

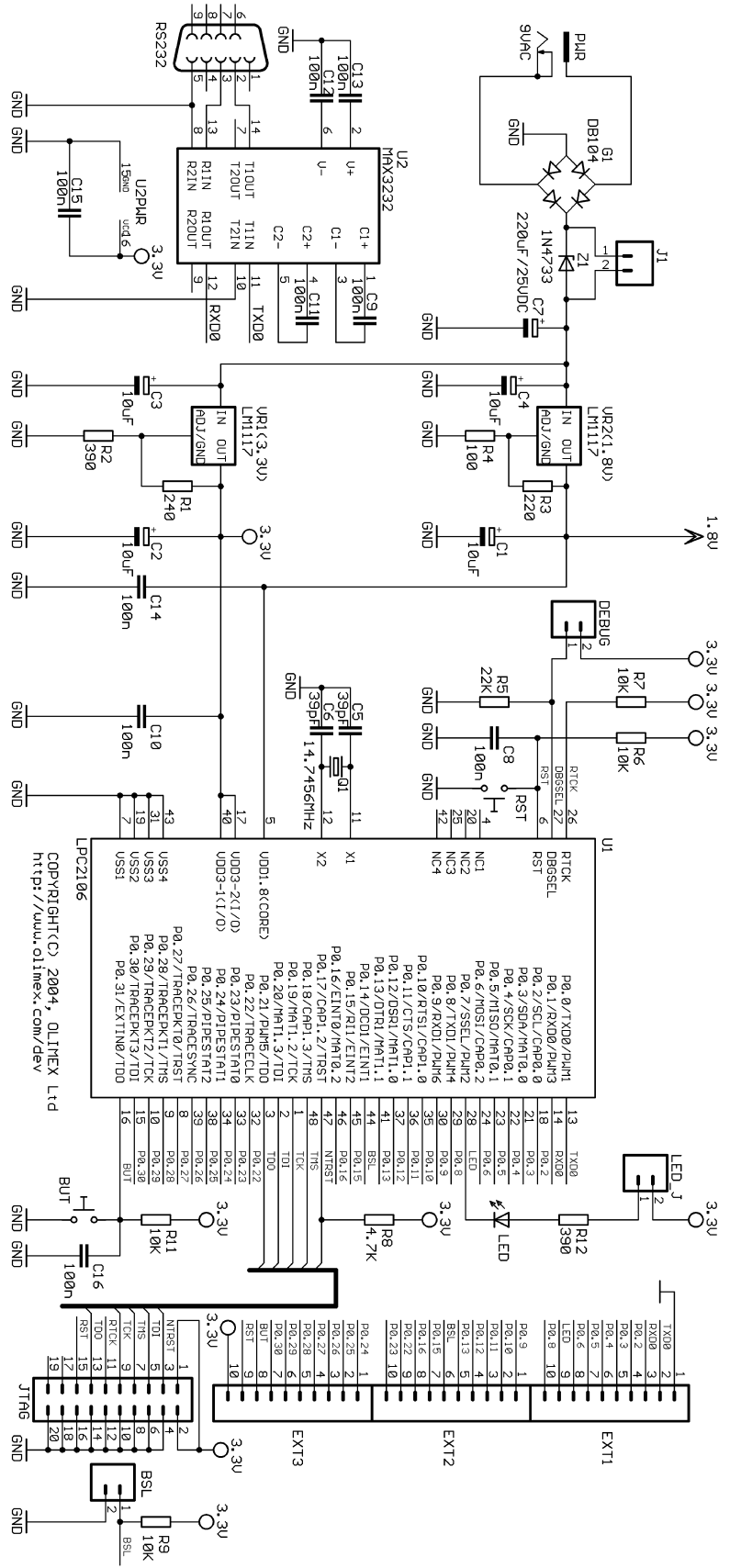

COPYRIGHT(C) 2004, OLIMEX LTD  
<http://www.olimex.com/dev>