

STR-P711 development board

Users Manual



All boards produced by Olimex are ROHS compliant

Revision C, June 2010

Copyright(c) 2010, OLIMEX Ltd, All rights reserved

INTRODUCTION

STR-P711 is development board with high performance STR711FR2T6 ARM7TDMI™ microcontroller from STMicroelectronics. This microcontroller supports serial interfaces such as USB, UART and other. On the board are available JTAG, SD/MMC card connector, UEXT, EXT, USB two RS232 connectors. All this can be used in a wide range of applications.

BOARD FEATURES

- MCU: **STR711FR2T6** 16/32 bit ARM7TDMI™ with 256K Bytes Program Flash, 64K Bytes RAM, USB 2.0, RTC, 12 bit ADC, 4x UARTs, 2x I2C, 2x SPI, 5x 32bit TIMERS, 2x PWM, 2x CCR, WDT, up to 50MHz operation
- standard JTAG connector with ARM 2x10 pin layout for programming/debugging with ARM-JTAG
- USB connector
- Two channel RS232 interface and drivers
- SD/MMC card connector
- two buttons
- trimpot connected to ADC
- two status LEDs
- Buzzer
- UEXT - 10 pin extension connector for Olimex addon peripherals like MP3, RF2.4Ghz, RFID etc. modules
- 2x SPI connectors
- I2C connector
- on board voltage regulator 3.3V with up to 800mA current
- single power supply: 6V AC or DC required, USB port can power the board
- power supply LED
- power supply filtering capacitor
- RESET circuit
- RESET button
- 4 Mhz crystal oscillator
- 32768 Hz crystal and RTC backup battery connector
- extension headers for all uC ports
- PCB: FR-4, 1.5 mm (0,062"), soldermask, silkscreen component print
- Dimensions: 120 x 80 mm (4.7 x 3.15")

ELECTROSTATIC WARNING

The **STR-P711** board is shipped in protective anti-static packaging. The board must not be subject to high electrostatic potentials. General practice for working with static sensitive devices should be applied when working with this board.

BOARD USE REQUIREMENTS

Cables: The cable you will need depends on the programmer/debugger you use. If you use [ARM-JTAG-EW](#), you will need USB A-B cable, if you use [AVR-JTAG](#), you will need LPT cable; you will also need RS232 cable.

Hardware: Programmer/Debugger [ARM-JTAG-EW](#), [ARM-JTAG](#), or other compatible programming/debugging tool if you work with EW-ARM.

You can use also [ARM-USB-OCD](#), [ARM-USB-TINY](#), ARM-USB-OCD-H, [ARM-USB-TINY-H](#), but we don't offer a project for this board with this programmers.

PROCESSOR FEATURES

STR-P711 board use STR711FR2T6 - ARM7TDMI™ microcontroller with these features:

- Memories:
 - 272 Kbytes (256+16K) FLASH program memory (100,000 cycles endurance, data retention 20 years)
 - 64 Kbytes RAM
 - External Memory Interface (EMI) for up to 4 banks of SRAM, Flash, ROM.
 - Multi-boot capability
- Clock, Reset and Supply Management
 - 3.3V application supply and I/O interface
 - Embedded 1.8V voltage regulator for core supply
 - 0 to 16 MHz external main oscillator
 - 32 kHz external backup oscillator
 - Internal PLL for CPU clock
 - Up to 50 MHz CPU operating frequency when executing from flash
 - Realtime Clock for clock-calendar function
 - 4 power saving modes: SLOW, WAIT, STOP and STANDBY modes
- Nested interrupt controller
 - Fast interrupt handling with multiple vectors
 - 32 vectors with 16 IRQ priority levels
 - 2 maskable FIQ sources

- 5 Timers
 - 16-bit watchdog timer
 - Four 16-bit timers each with: 2 input captures, 2 output compares, PWM and pulse counter modes
- Communications Interfaces
 - 2 I²C interfaces (1 multiplexed with SPI)
 - 4 UART asynchronous serial communications interfaces
 - Smart Card ISO7816-3 interface on UART1
 - 2 BSPI synchronous serial interfaces
 - USB v 2.0 Full Speed (12Mbit/s) Device Function with Suspend and Resume support
 - HDLC synchronous communications interface
- 4-channel 12-bit A/D Converter
 - Conversion time:
 - 4 channels: up to 500 Hz (2 ms)
 - 1 channel: up to 1 kHz (1 ms)
 - Conversion range: 0 to 2.5V
- Development Tools Support
 - JTAG with debug mode trigger request

BLOCK DIAGRAM

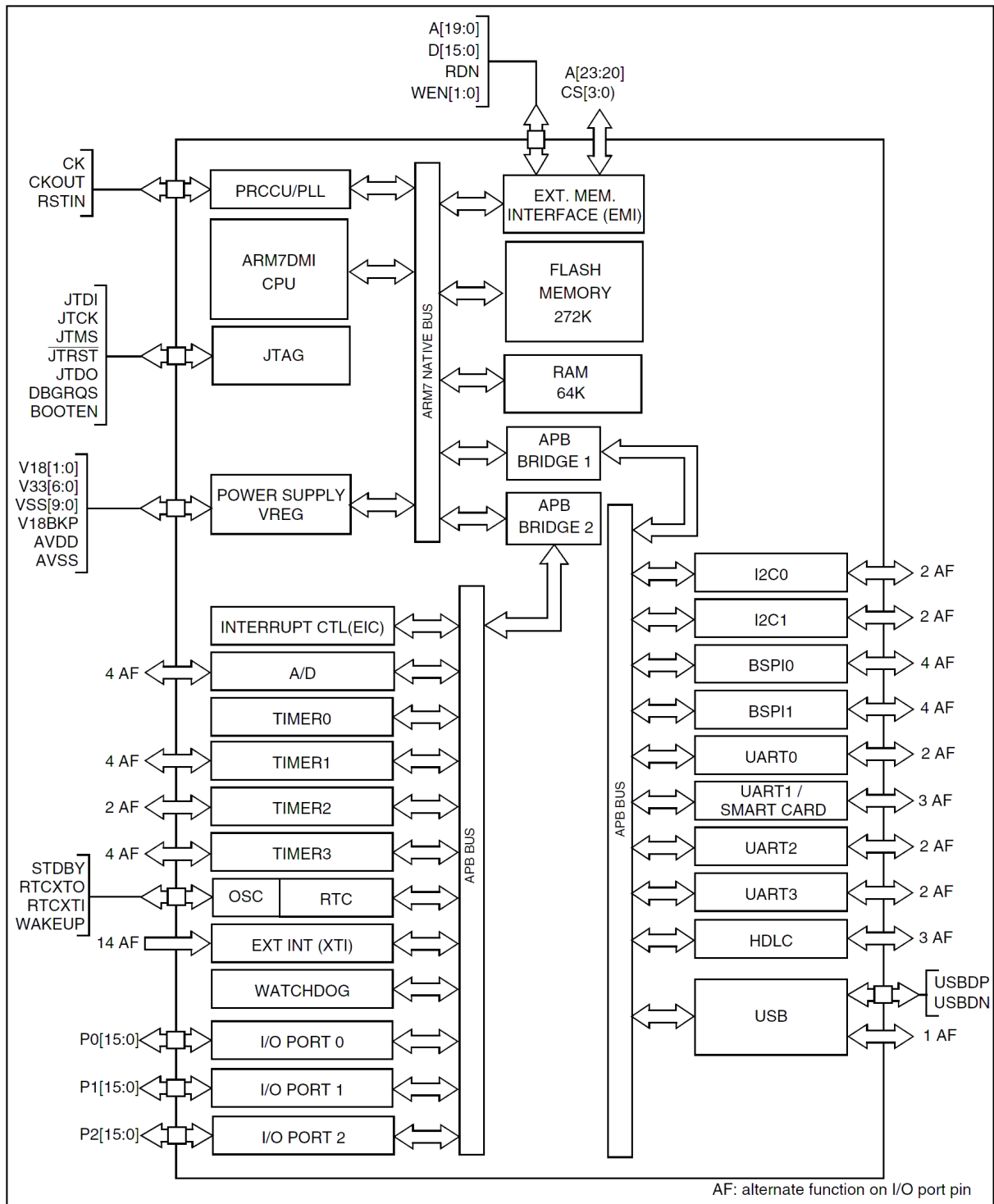

MEMORY MAP

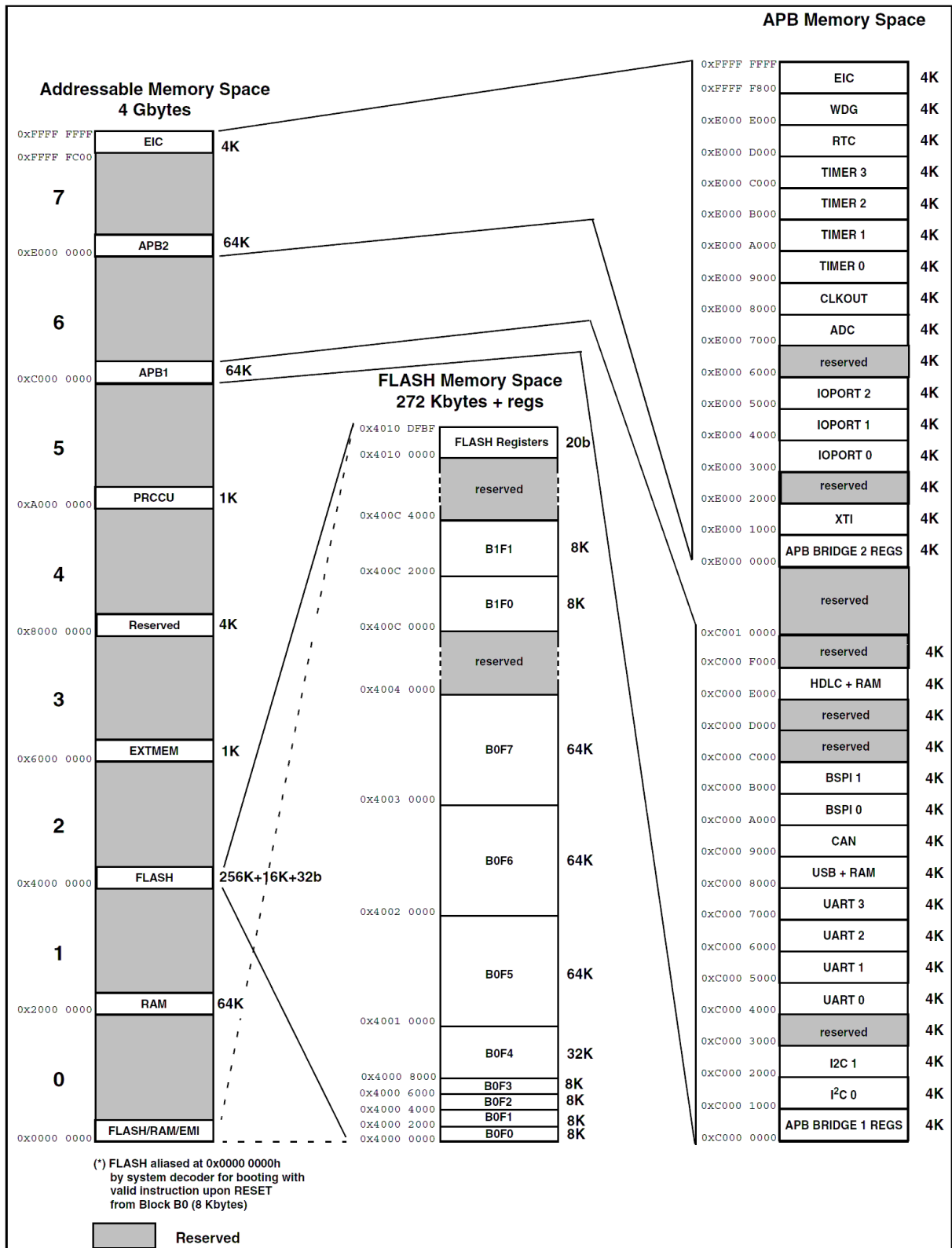

SCHEMATIC

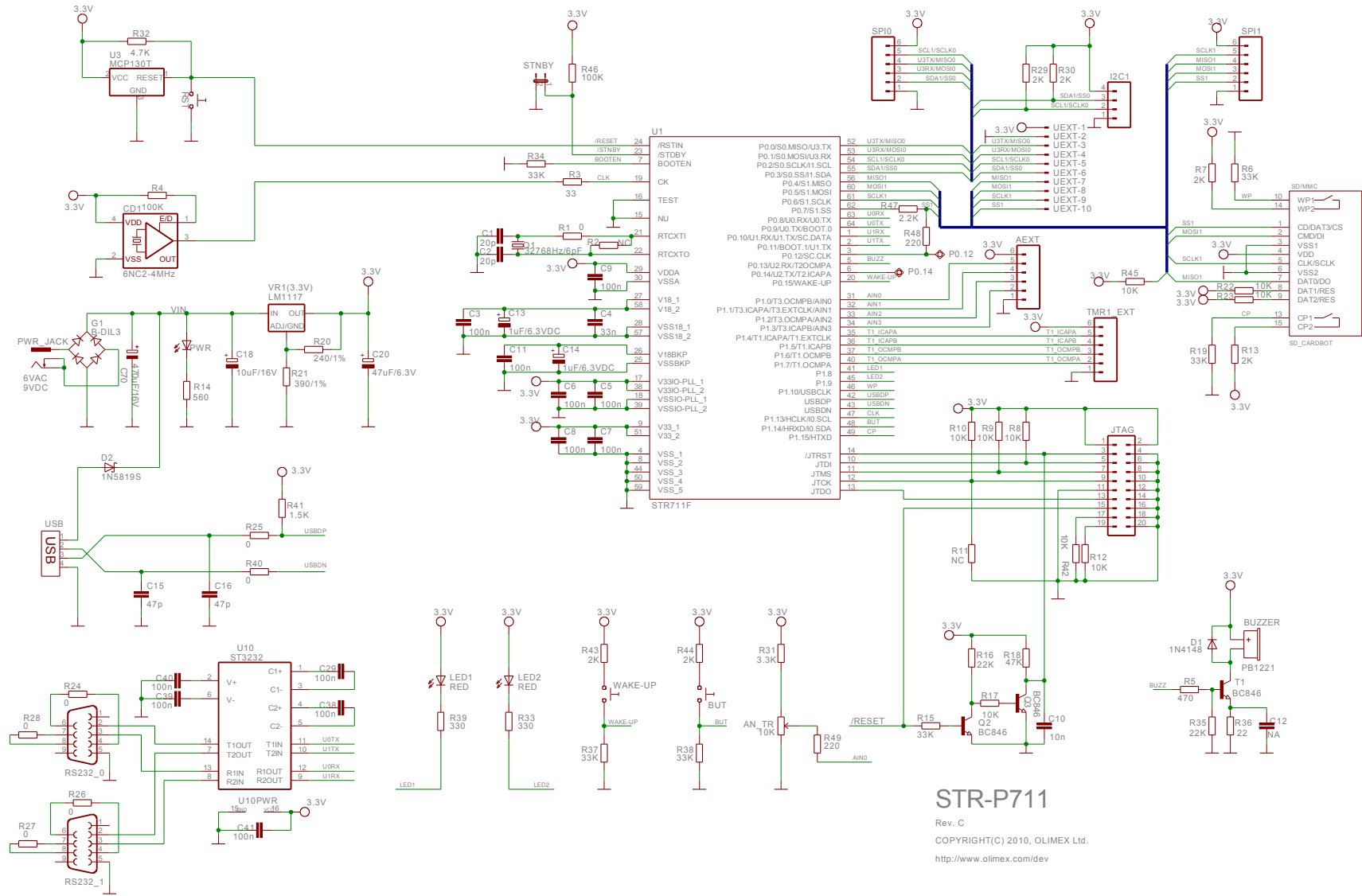

STR-P711

Rev. C
 COPYRIGHT(C) 2010, OLIMEX Ltd.
<http://www.olimex.com/dev>

BOARD LAYOUT

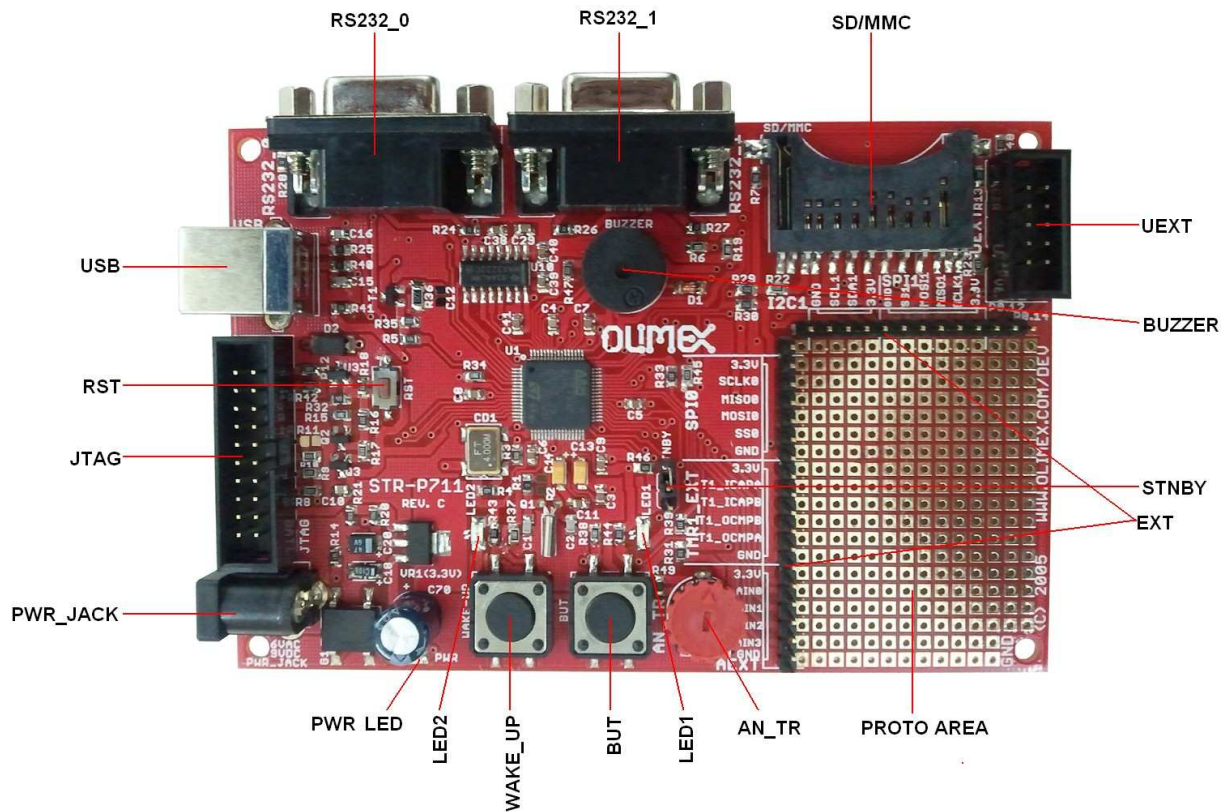

POWER SUPPLY CIRCUIT

STR-P711 can take power (+9 VDC or 6VAC) from PWR_JACK, and (+5 V) from USB.

The programmed board power consumption is about 90 mA with all peripherals enabled.

RESET CIRCUIT

STR-P711 reset circuit includes R32 (4.7k), U3 (MCP130), JTAG connector pin 15 and RESET button.

CLOCK CIRCUIT

Quartz crystal Q1 (32.768kHz) is connected to STR711FR2T6 pin 21 (RTCXTI) and pin 22 (RTCXTO).

Clock Oscillator CD1 (4MHz) is connected to STR711FR2T6 pin 19 (CK).

JUMPER DESCRIPTION

STNBY



When this jumper is open, STR711FR2T6 pin 23 (/STDBY) is connected to pull-up resistor R46 (100k); when jumper STNBY is closed, STR711FR2T6 pin 23 (/STDBY) is connected to ground.

Default state is open.

INPUT/OUTPUT

Status led (red) with name **LED1** connected to **STR711FR2T6** pin 41 (P1.8).

Status led (red) with name **LED2** connected to **STR711FR2T6** pin 45 (P1.9).

Power-on LED (red) with name **PWR** - this LED shows that +3.3V is applied to the board.

User button with name **WAKE_UP** connected to **STR711FR2T6** pin 20 (P0.15/WAKE-UP).

User button with name **BUT** connected to **STR711FR2T6** pin 48 (P1.14/HRXD/I0.SDA).

User button with name **RESET** connected to **STR711FR2T6** pin 24 (/RSTIN).

Trimpot with name **AN_TR** connected to **STR711FR2T6** pin 31 (P1.0/T3.OCMPB/AIN0) and AEXT pin 5.

Buzzer with name **BUZZER** connected to **STR711FR2T6** pin 5 (P0.13/U2.RX/T20CMPA).

EXTERNAL CONNECTORS DESCRIPTION

RS232 0

Pin #	Signal Name
1	NC
2	T1OUT
3	R1IN
4	Via 0 Ohm to pin 6
5	GND
6	Via 0 Ohm to pin 4
7	Via 0 Ohm to pin 8
8	Via 0 Ohm to pin 7
9	NC

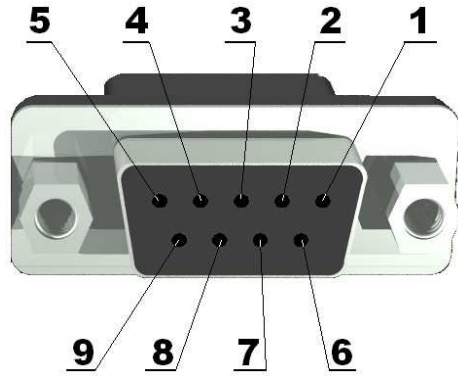

RS232 1

Pin #	Signal Name
1	NC
2	T2OUT
3	R2IN
4	Via 0 Ohm to pin 6
5	GND
6	Via 0 Ohm to pin 4
7	Via 0 Ohm to pin 8
8	Via 0 Ohm to pin 7
9	NC

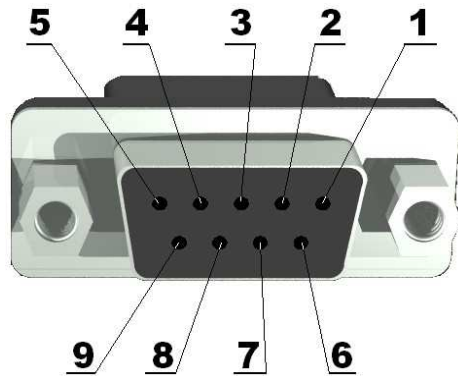

PWR JACK

Pin #	Signal Name
1	Power Input
2	GND

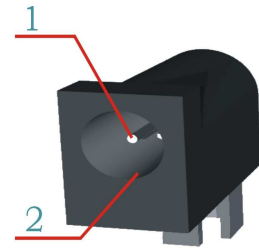

UEXT

Pin #	Signal Name
1	3.3V
2	GND
3	U3TX/MISO0
4	U3RX/MOSI0
5	SCL1/SCLK0
6	SDA1/SS0
7	MISO1
8	MOSI1
9	SCLK1
10	SS1

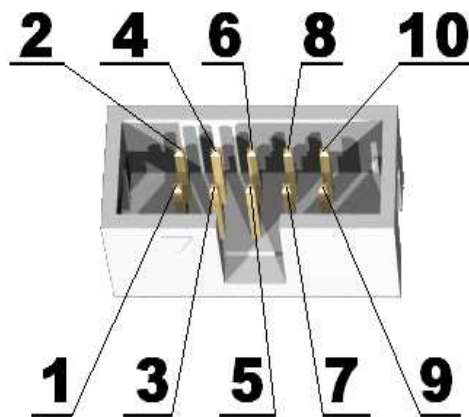

USB

Pin #	Signal Name
1	VIN
2	USBDN
3	USBDP
4	GND

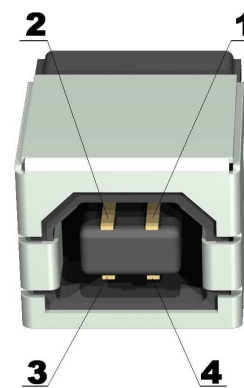

JTAG

The JTAG connector allows the software debugger to talk via a JTAG (Joint Test Action Group) port directly to the core. Instructions may be inserted and executed by the core thus allowing STR711F memory to be programmed with code and executed step by step by the host software.

For more details refer to IEEE Standard 1149.1 - 1990 Standard Test Access Port and Boundary Scan Architecture and STR711FR2T6 datasheets and users manual.

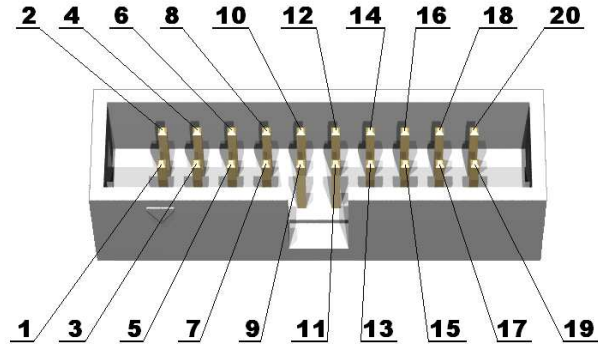

Pin #	Signal Name	Pin #	Signal Name
1	3.3V	2	3.3V
3	/JTRST	4	GND
5	JTDI	6	GND
7	JTMS	8	GND
9	JTCK	10	GND
11	GND	12	GND
13	JTDO	14	GND
15	/RESET	16	GND
17	pull-down	18	GND
19	pull-down	20	GND

EXT

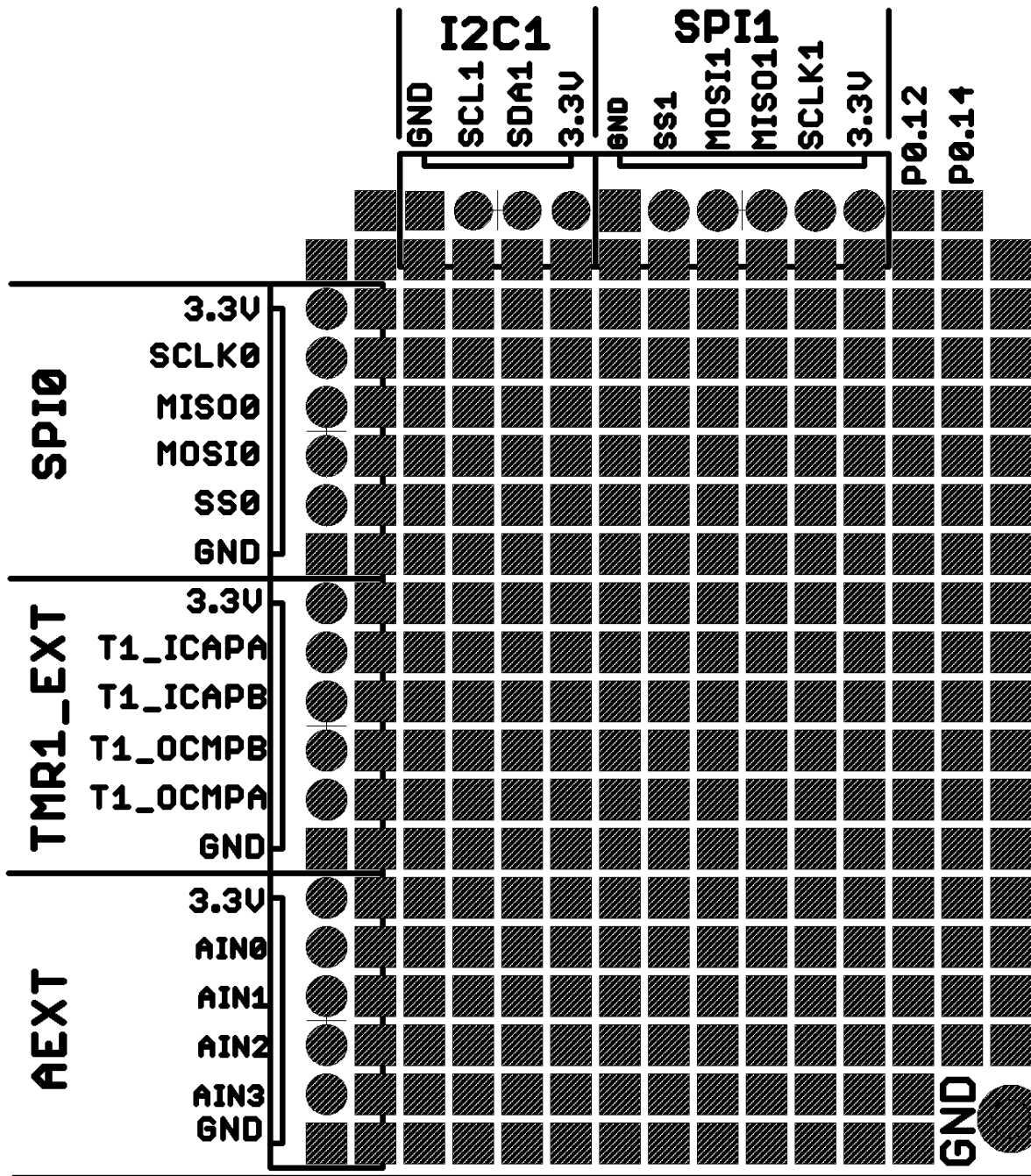

SD/MMC

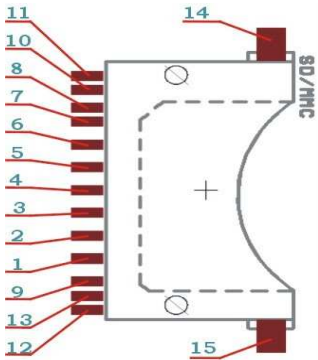

Pin #	Signal Name	Pin #	Signal Name
1	SS1	2	MOSI1
3	GND	4	VCC
5	SCLK1	6	GND
7	MISO1	8	pull-up
9	pull-up	10	WP
11	-	12	-
13	CP	14	pull-up
15	pull-up		

MECHANICAL DIMENSIONS

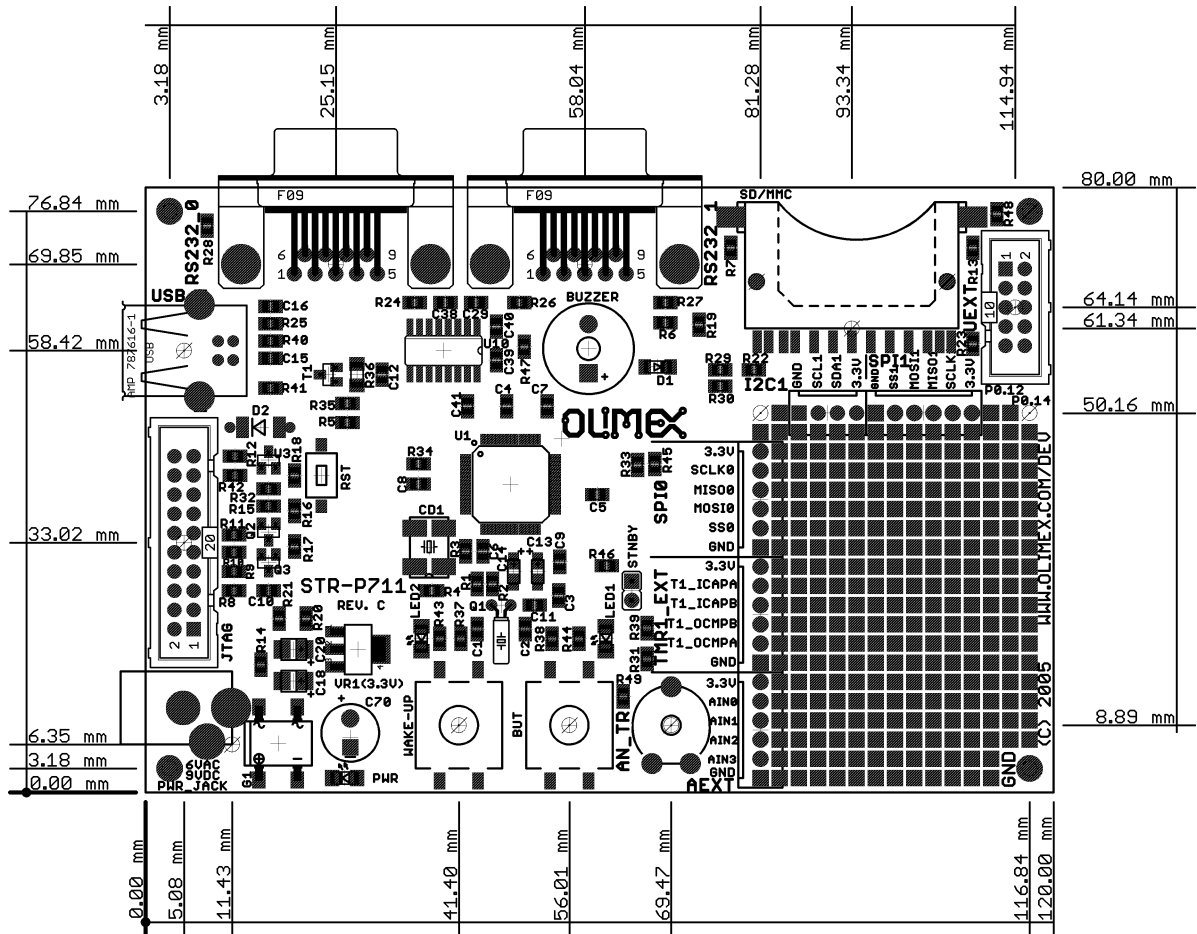

AVAILABLE DEMO SOFTWARE

- Buttons and LEDs
- Sample mouse driver with STR711
- UART routines
- SD/MMC read/write routines

ORDER CODE

STR-P711 - assembled and tested board, includes STR711FR2T6
microcontroller

How to order?

You can order to us directly or by any of our distributors.
Check our web www.olimex.com/dev for more info.

Revision history

Revision C, June 2010

Disclaimer

© 2010 Olimex Ltd. All rights reserved. Olimex®, logo and combinations thereof, are registered trademarks of Olimex Ltd. Other terms and product names may be trademarks of others.

The information in this document is provided in connection with Olimex products. No license, express or implied or otherwise, to any intellectual property right is granted by this document or in connection with the sale of Olimex products.

Neither the whole nor any part of the information contained in or the product described in this document may be adapted or reproduced in any material from except with the prior written permission of the copyright holder.

The product described in this document is subject to continuous development and improvements. All particulars of the product and its use contained in this document are given by OLIMEX in good faith. However all warranties implied or expressed including but not limited to implied warranties of merchantability or fitness for purpose are excluded.

This document is intended only to assist the reader in the use of the product. OLIMEX Ltd. shall not be liable for any loss or damage arising from the use of any information in this document or any error or omission in such information or any incorrect use of the product.