

AVR-IO (Rev. B) DEVELOPMENT BOARD WITH 4 OPTOISOLATED INPUTS AND 4 RELAY OUTPUTS

Features:

AVR-IO is development board for 20 pin AVR microcontrollers with following features:

- 4 optocoupler isolated inputs
- 4 relay with 5A/240VAC contacts
- 10 MHz crystal resonator
- status LED
- RS232 Tx, Rx and connector
- ICSP 10 pin connector (STK compatible)
- RESET IC ZM33064C
- 10MHz quartz oscillator
- DIL20 microcontroller socket
- power supply plug in connector
- screw terminal blocks on all inputs and outputs
- +5V power supply voltage regulator
- 0.1" (2.54 mm) grid
- dimensions: 100x80 mm
- four mounting holes

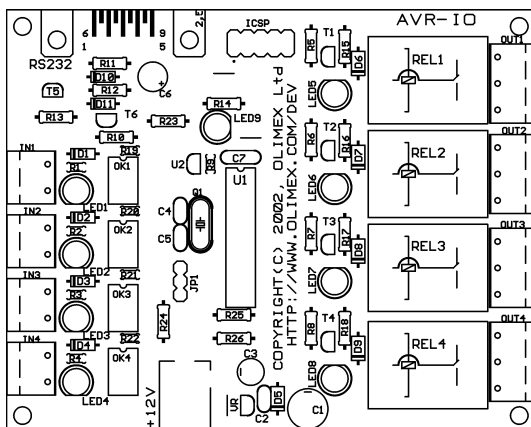

Programming:

To program AVR-IO you need serial port or parallel port AVR-ICSP programmer dongle (Olimex part # AVR-PG1B or AVR-PG2B).

The serial port ICSP programmer (AVR-PG1B) works with PonyProg software by from Claudio Lanconelli and the latest release may be download for free from <http://www.lancos.com>

The parallel port ICSP programmer (AVR-PG2B) works with AVR ISP from Atmel and may be download for free from Atmel's web site.

ICSP interface:

The ICSP connector is 2x5 pin with 0,1" step with Atmel STKxxx compatible layout. The PIN.1 is marked with square pad on bottom and arrow on top. ICSP signals are: 1- MOSI, 2- VCC, 3- NC, 4- GND, 5- RST, 6- GND, 7- SCK, 8- GND, 9- MISO, 10- GND

TOP view PCB board layout:

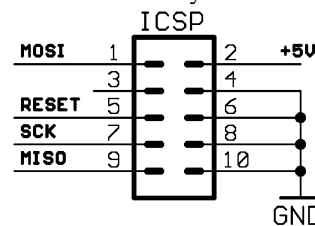

RS232 interface connection:

Rx – PD0, Tx – PD1

Optoisolated inputs:

IN1 to PD2/INT0, IN2 to PD3/INT1 or PD4/T0 via JP1 jumper split, IN3 to PD5/T1, IN4 to PD6/ICP. All inputs have LED to visualize input state.

Relay outputs:

OUT1 to PB3, OUT2 to PB2, OUT3 to PB1 and OUT4 to PB0. All outputs have LED to visualize relay state

Status LED:

Connected to PB4

RESET supervisor circuit:

IC ZM33064C with 4.6V threshold.

Supported devices:

AT90S1200 and AT90S2313 microcontrollers.

Power supply:

The power supply should be in range +10 +14VDC.

Ordering codes:

AVR-IO - assembled and tested

Copyright(c) 2002, OLIMEX Ltd, All rights reserved.

Development boards for PIC, AVR and MSP430 microcontrollers <http://www.olimex.com/dev>

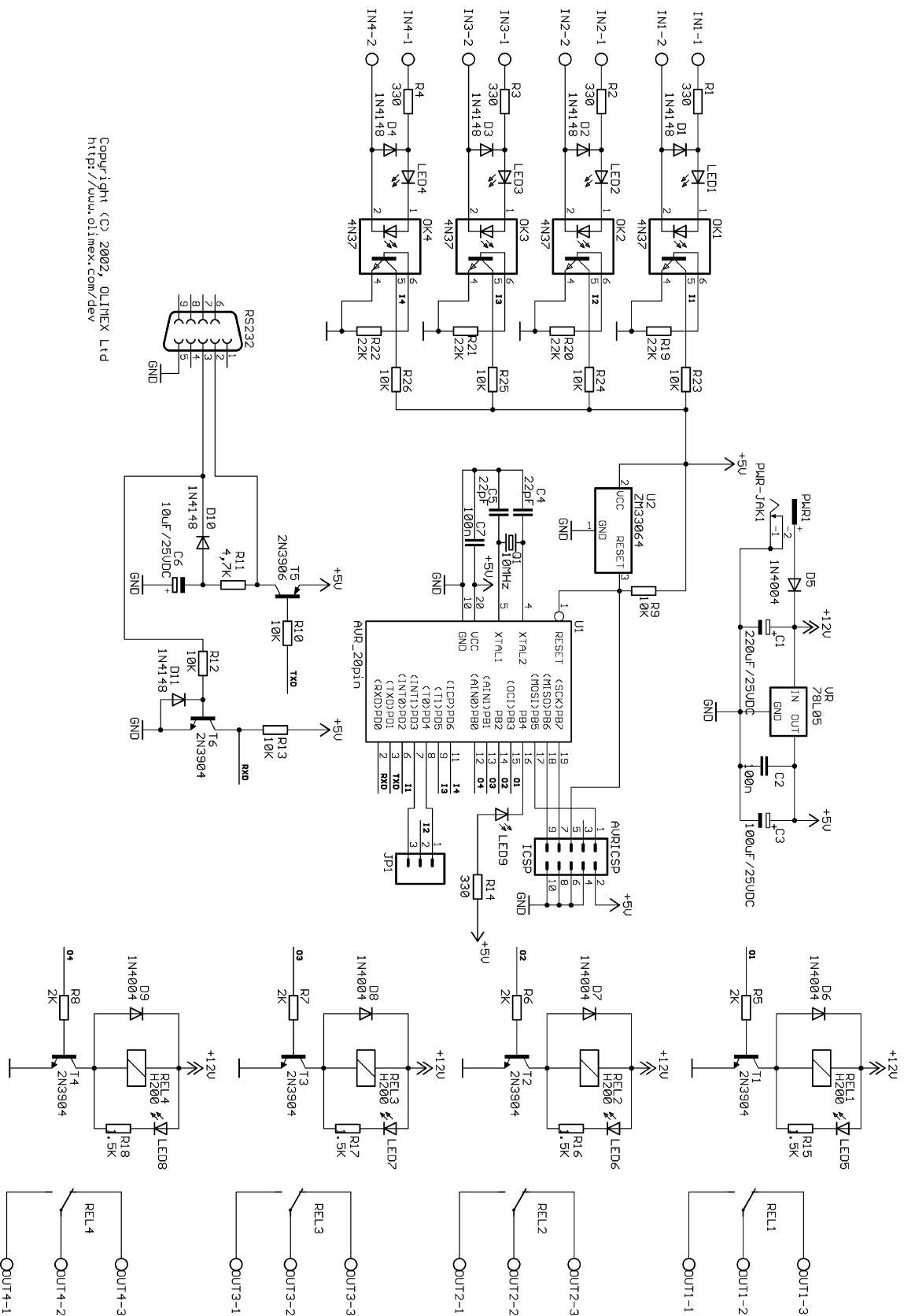

Copyright (C) 2002, OLIMEX Ltd
<http://www.olimex.com/dev>