

## AVR-MT (Rev. B) DEVELOPMENT BOARD WITH 10 PIN ICSP FOR 20 PIN AVR MICROCONTROLLERS

### **Features:**

AVR-MT (mini terminal) is development board for 20 pin AVR microcontrollers with following features:

- ICSP 10 pin connector (STK compatible)
- LCD 16x1 alphanumeric display
- 6 buttons
- Dallas iButton interface
- Frequency input
- RS232 interface and connector
- RS232 TTL level interface and connector
- status LED
- relay with 5A/250VAC contacts
- screw terminal blocks on relay contacts
- Audio buzzer
- RESET IC ZM33064C
- 10MHz quartz oscillator
- DIL20 microcontroller socket
- +5V power supply voltage regulator
- power supply plug in connector
- dimensions: 120x36 mm
- four mounting holes

### **Programming:**

To program AVR-MT you need serial port or parallel port AVR-ICSP programmer dongle (Olimex part # AVR-PG1B or AVR-PG2B).

The serial port ICSP programmer (AVR-PG1B) works with PonyProg software by from Claudio Lanconelli and the latest release may be download for free from <http://www.lancos.com>  
The parallel port ICSP programmer (AVR-PG2B) works with AVR ISP from Atmel and may be download for free from Atmel's web site.

### **ICSP interface:**

The ICSP connector is 2x5 pin with 0,1" step and Atmel STKxxx compatible layout. The PIN.1 is marked with square pad on bottom and arrow on top. ICSP signals are: 1- MOSI, 2- VCC, 3- NC, 4- GND, 5- RST, 6- GND, 7- SCK, 8- GND, 9- MISO, 10- GND.

ICSP TOP view PCB board layout:

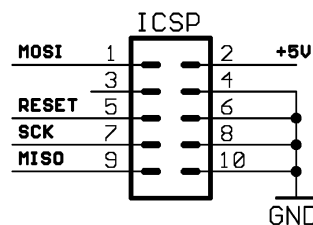

### **LCD connection:**

LCD is connected for 4-bit interface

RS - LCD register select PD4

E - LCD enable PD6

D4 - PB0

D5 - PB1

D6 - PB2

D7 - PB3

Sample demo program how to drive the LCD is available on Olimex's site.

### **RS232 interface connection:**

Microcontroller connection: Rx – PD0, Tx – PD1

TTL connector: PIN.1 (square) –Tx, PIN.2 –Rx, PIN.3 – VCC, PIN.4 – GND.

RS232 connector: PIN.2 – Tx, PIN.3 – Rx, PIN.5 – GND.

### **Dallas iButton interface:**

Connected to PD2 via protection circuit.

Dallas connector: PIN.1 (square) – Dallas input, PIN.2 – GND.

### **Buttons connection:**

The Button interface uses three microcontroller ports PB7, PB6, PB5. The same ports are used for ICSP programming, so it's very important to not touch the buttons while program the AVR microcontroller. The ports are connected with pull down resistors and are read as "0". To scan the buttons user should set one of the ports in "1" and to check the other two ports.

For example: set port PB7 as output PB5, PB6 as inputs and make PB7= 1. If buttons B3 is pressed PB5 will be "1" too, if button B5 is pressed PB6 will be "1" too. The same way you can scan all other buttons.

**Audio buzzer interface:**

Connected to PB4. User must apply frequency to this microcontroller pin to sound.

**Relay output:**

Connected to PD3.

**Status LED:**

Connected in parallel with the relay to PD3. LED is ON when relay is ON.

**RESET supervisor circuit:**

IC ZM33064C with 4.6V threshold.

**Supported devices:**

AT90S1200 and AT90S2313 microcontrollers.

**Power supply:**

The power supply should be in range +10 +14VDC.

**Ordering codes:**

AVR-MT - assembled and tested

**Board component locations:**

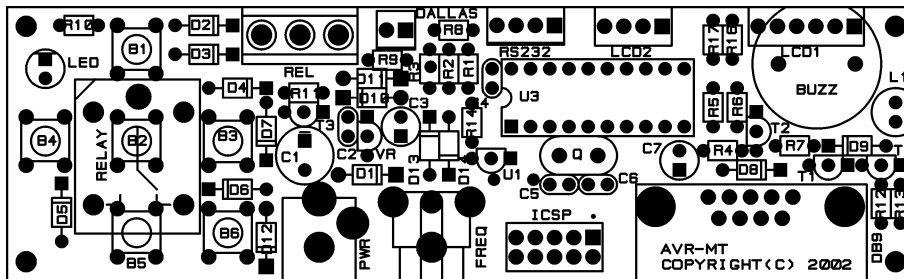

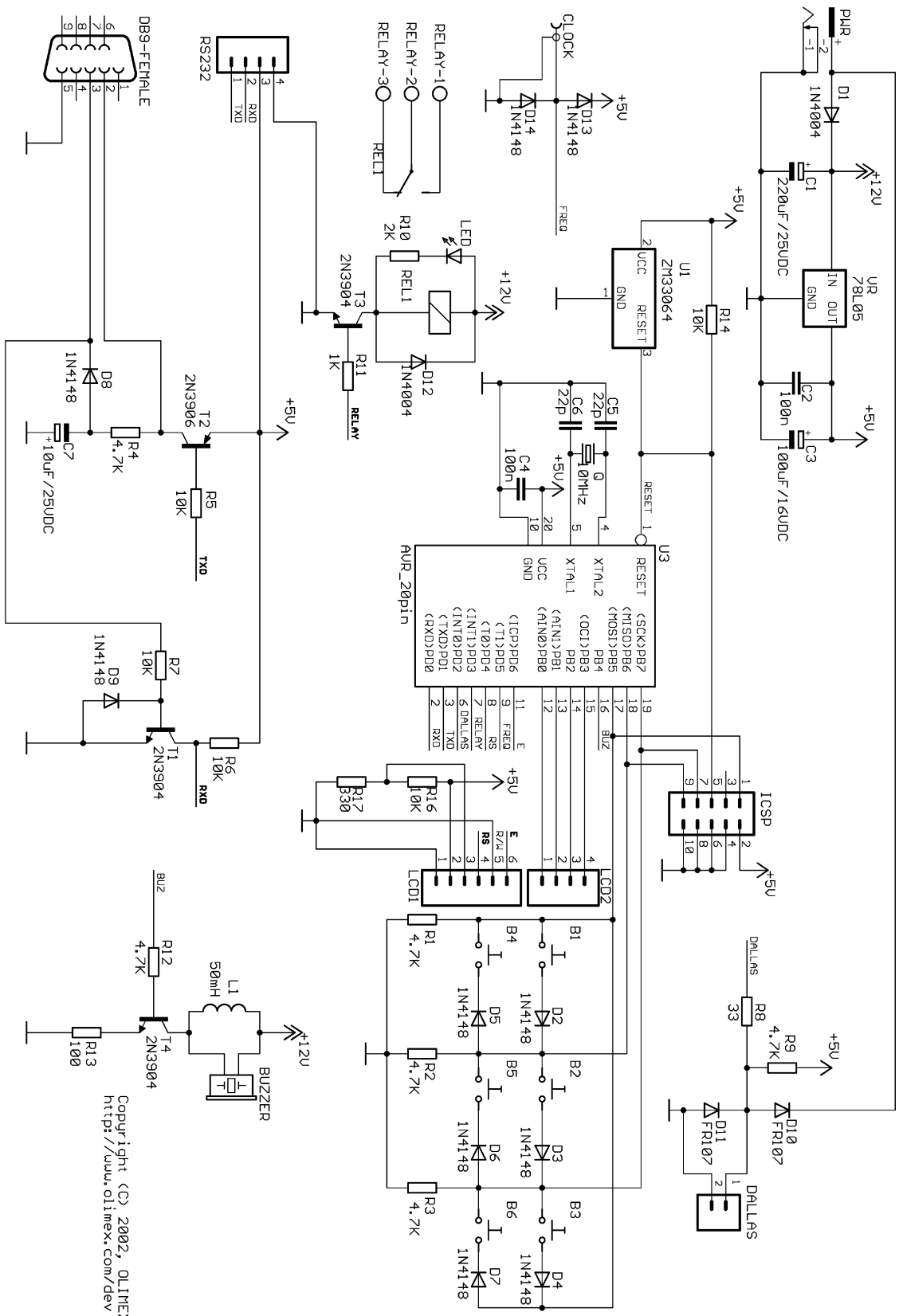

Copyright (C) 2002, OLIMEX Ltd  
<http://www.olimex.com/dev>