

MSP430-4619LCD development board

Users Manual



All boards produced by Olimex are ROHS compliant

Revision Initial, June 2011
Copyright(c) 2011, OLIMEX Ltd, All rights reserved

INTRODUCTION:

MSP430-4619LCD is MPS430FG4619 starterkit development board with color graphics LCD, accelerometer, JTAG, SD/MMC card holder, joystick, two buttons, serial infrared transceiver and extension headers for most of the microcontroller pins. All this allows you to build a different projects to be used in a wide range of applications.

BOARD FEATURES:

- MCU: **MSP430FG4619** with 120K Bytes Program Flash, 256 Bytes data Flash, 4K Bytes RAM
- NOKIA 6610 LCD 128x128 pixels 12 bit color LCD with backlight
- Joystick with 4 directions and push button function
- two buttons
- SD/MMC card connector
- MMA7620 3 axis accelerometer
- IrDA transceiver
- UEXT connector which allow other Olimex's modules to be connected like: MOD-MP3, MOD-NRF24L01, etc.
- JTAG connector
- 32 768 Hz oscillator crystal
- 8Mhz crystal oscillator
- power supply voltage regulators and filtering capacitor
- extension headers for all uC pins
- Battery holder for 2 x 1.5 V "AA" batteries
- PCB: FR-4, 1.5 mm (0,062"), soldermask, white silkscreen component print
- Dimensions: 81.20 x 62.48 mm (3.20 x 2.46")

ELECTROSTATIC WARNING:

The **MSP430-4619LCD** board is shipped in protective anti-static packaging. The board must not be subject to high electrostatic potentials. General practice for working with static sensitive devices should be applied when working with this board.

BOARD USE REQUIREMENTS:

Cables: The cable you will need depends on the programmer/debugger you use. If you use MSP-JTAG-TINY, MSP-JTAG-TINY-V2, MSP-JTAG-ISO, you will need USB A-B cable, if you use MSP-JTAG, you will need LPT cable.

Hardware: Programmer/Debugger [MSP-JTAG](#), [MSP-JTAG-TINY](#), MSP-JTAG-TINY-V2, [MSP-JTAG-ISO](#), [MSP-JTAG-RE](#), or other compatible programming/debugging tool.

PROCESSOR FEATURES:

MSP430-4619LCD board use mixed signal microcontroller **MSP430FG4619** from Texas Instruments, with these features:

- Low Supply-Voltage Range, 1.8 V to 3.6 V
- Ultralow-Power Consumption:
 - Active Mode: 350 μ A at 1 MHz, 2.2 V
 - Standby Mode: 1.1 μ A
 - Off Mode (RAM Retention): 0.3 μ A
- Five Power Saving Modes
- Wake-Up From Standby Mode in less than 6 μ s
- 16-Bit RISC Architecture, Extended Memory, 125-ns Instruction Cycle Time
- Three Channel Internal DMA
- 12-Bit A/D Converter With Internal Reference, Sample-and-Hold and Autoscan Feature
- Three Configurable Operational Amplifiers
- Dual 12-Bit D/A Converters With Synchronization
- 16-Bit Timer_A With Three Capture/Compare Registers
- 16-Bit Timer_B With Seven Capture/Compare-With-Shadow Registers
- On-Chip Comparator
- Supply Voltage Supervisor/Monitor With Programmable Level Detection

- Serial Communication Interface (USART1), Select Asynchronous UART or Synchronous SPI by Software
- Universal Serial Communication Interface
 - Enhanced UART supporting auto-baudrate detection
 - IrDA Encoder and Decoder
 - Synchronous SPI
 - I2CTM
- Serial Onboard Programming, No External Programming Voltage Needed
Programmable Code Protection by Security Fuse
- Brownout Detector
- Basic Timer with Real Time Clock Feature
- Integrated LCD Driver up to 160 Segments With Regulated Charge Pump
- 120KB+256B Flash Memory
- 4KB RAM

BLOCK DIAGRAM:

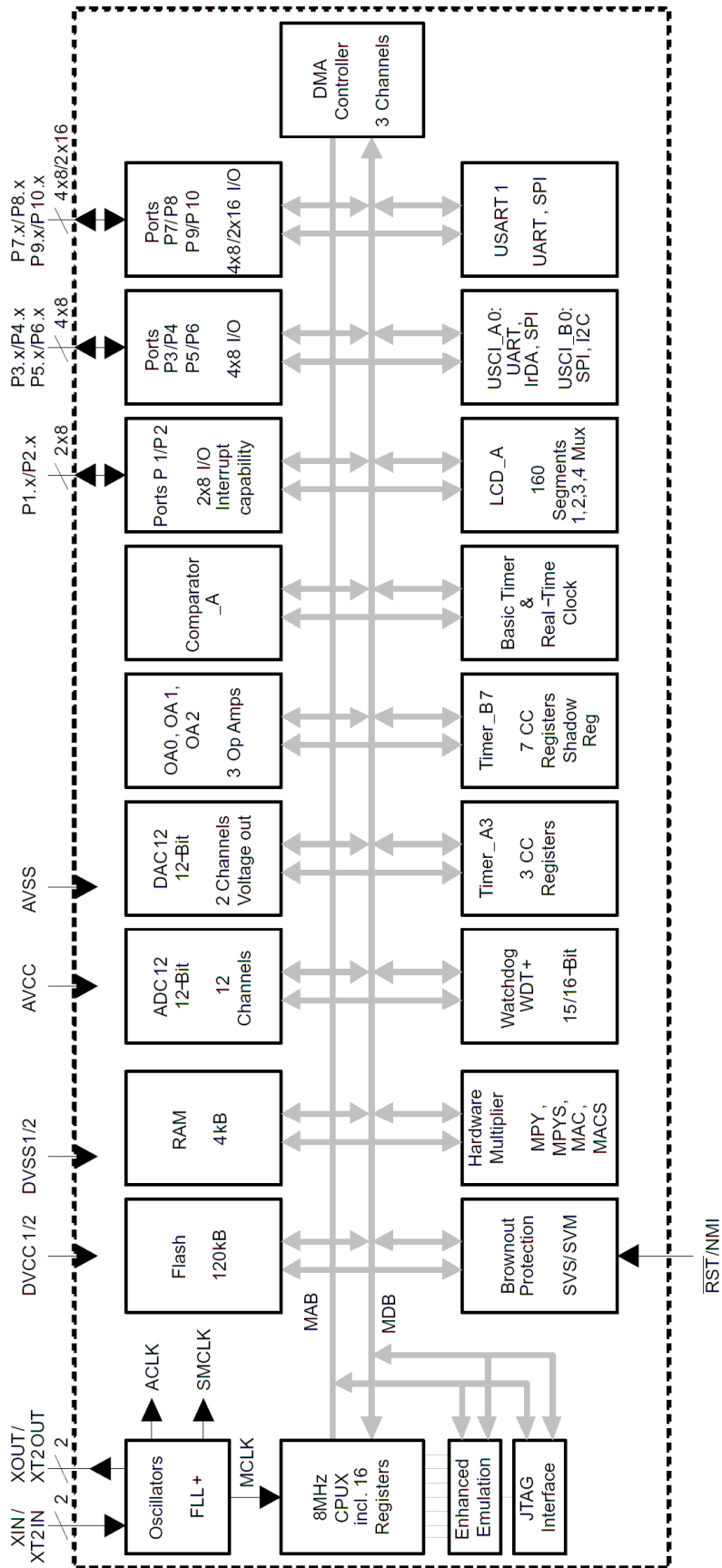

MEMORY ORGANIZATION:

Memory Main: interrupt vector Main: code memory	Size Flash Flash	120KB 0FFFFh – 0FFC0h 01FFFFh – 002100h
RAM (Total)	Size	4KB 020FFh – 01100h
Extended	Size	2KB 020FFh – 01900h
Mirrored	Size	2KB 018FFh – 01100h
Information memory	Size Flash	256 Byte 010FFh – 01000h
Boot memory	Size ROM	1KB 0FFFh – 0C00h
RAM (mirrored at 018FFh – 01100h)	Size	2KB 09FFh – 0200h
Peripherals	16-bit 8-bit 8-bit SFR	01FFh – 0100h 0FFh – 010h 0Fh – 00h

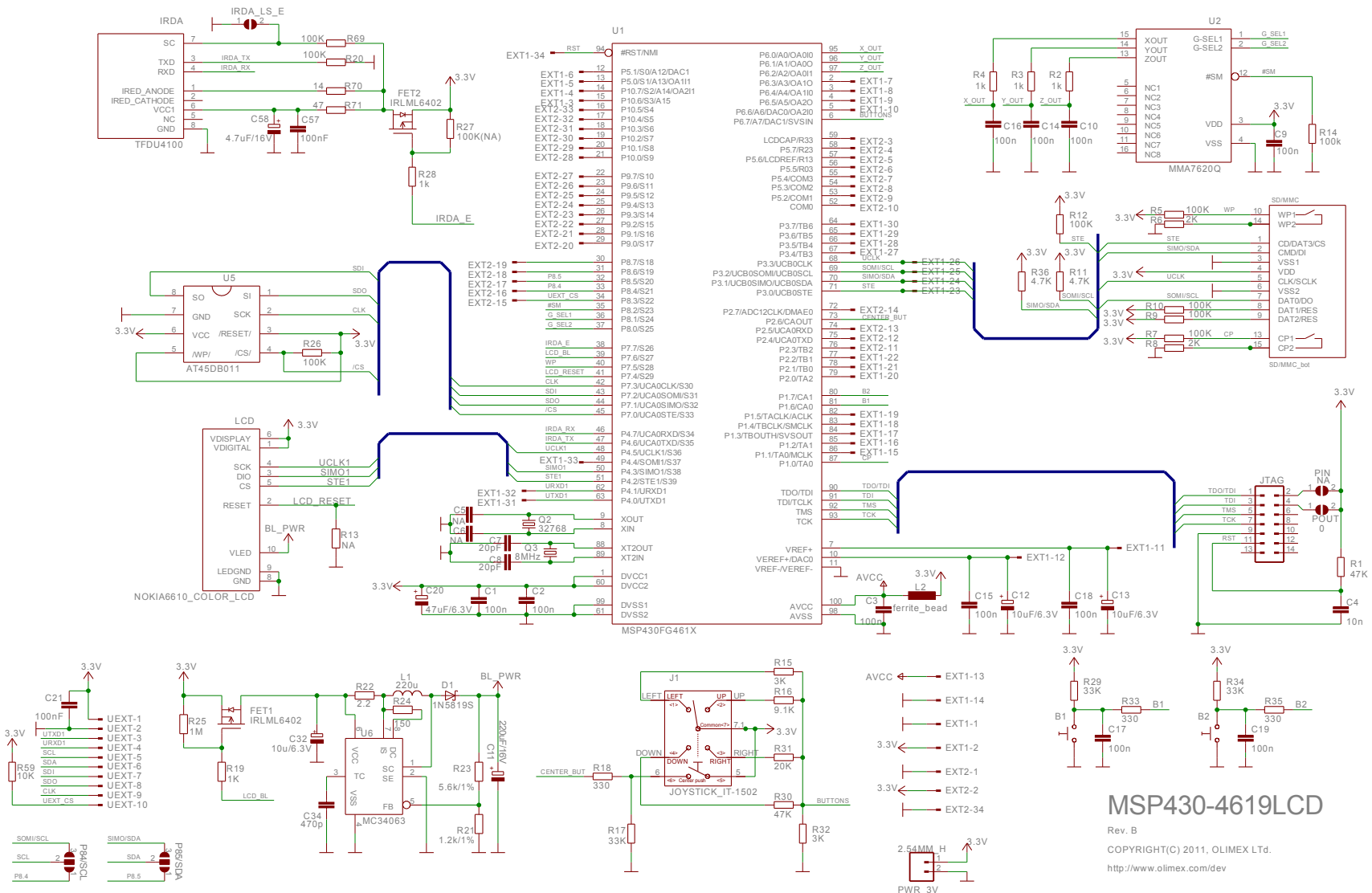

MSP430-4619LCD
 Rev. B
 COPYRIGHT(C) 2011, OLIMEX LTD.
<http://www.olimex.com/dev>

BOARD LAYOUT:

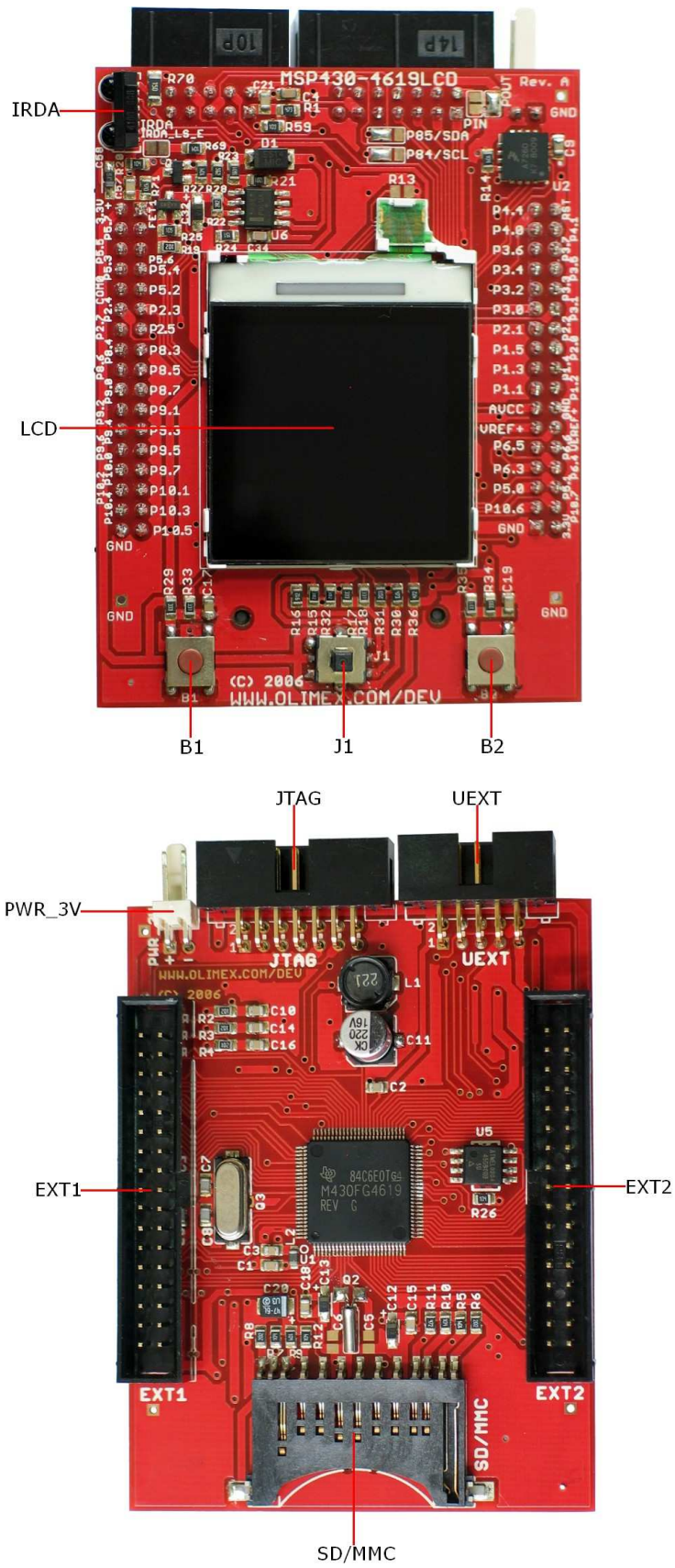

POWER SUPPLY CIRCUIT:

MSP430-4619LCD is typically power supplied with 3 VDC (2 x 1.5V “AA” batteries) via PWR_3V connector.

The programmed board power consumption is about 120 mA with all peripherals enabled

RESET CIRCUIT:

MSP430-4619LCD reset circuit includes R1 (47kΩ), C4 (10nF), JTAG connector pin 11 and MSP430FG4619 pin 94 (#RST/NMI).

CLOCK CIRCUIT:

Quartz crystal 8 MHz is connected to MSP430FG4619 pin 88 (XT2OUT) and pin 89 (XT2IN).

Quartz crystal 32.768 kHz is connected to MSP430FG4619 pin 8 (XIN) and pin 9 (XOUT).

JUMPER DESCRIPTION:

P_IN



When this jumper is closed, the board is power supplied by the standard JTAG pin 2. This is only possible when the consumption of the board is not very high which is typically the case with MSP430 microcontrollers. If this jumper is open the board should be power supplied by another external source. This jumper and P_OUT should always be reversely open/closed, i.e. if P_IN is closed, P_OUT should be open and vice versa.

Default state is opened.

P_OUT



When this jumper is closed, the board is power supplied not by the JTAG but from external source. Then the JTAG has to synchronize with the working voltages which is done through this line. This is especially important when debugging with JTAG. This jumper and P_IN should always be reversely open/closed, i.e. if P_OUT is closed, P_IN should be open and vice versa.

Default state is closed.

IRDA_LS_E



When this jumper is closed, TFDU4100 signal SC (Sensitivity control) is connected to GND, which means that sensitivity is decreased.

When this jumper is opened, TFDU4100 signal SC (Sensitivity control) is set to high, which means that sensitivity is increased and therefore transmission range is increased up to 3 meters

Default state is opened.

P84/SCL



When this jumper is shorted in position P84, UEXT pin 5 (SCL) is connected to MSP430FG4619 pin 33 (P8.4/S21). When this jumper is shorted in position SCL, UEXT pin 5 (SCL) is connected to MSP430FG4619 pin 69 (P3.2/UCB0SOMI/UCB0SCL).
Default state is P84 shorted.

P85/SDA



When this jumper is shorted in position P85, UEXT pin 6 (SDA) is connected to MSP430FG4619 pin 32 (P8.5/S20). When this jumper is shorted in position SDA, UEXT pin 6 (SDA) is connected to MSP430FG4619 pin 70 (P3.1/UCB0SIMO/UCB0SDA).
Default state is P85 shorted.

INPUT/OUTPUT:

User button with name **B1** connected to **MSP430FG4619** pin 81 (P1.6/CA0).

User button with name **B2** connected to **MSP430FG4619** pin 80 (P1.7/CA1).

Joystick button with name **J1** this is 4 directions plus center button. In the schematic the joystick four direction switches are connected to **MSP430FG4619** pin 6 (P6.7/A7/DAC1/SVSIN) – signal “BUTTONS”. Each of this four direction switches is connected to signal “BUTTONS” via resistors with different values. The RIGHT direction via R31 (20k); LEFT – via RR15 (3k); DOWN – via R30 (47k) and UP – via R16 (9.1k). The CENTER is connected to MSP430FG4619 pin 73 (P2.6/CAOUT).

LCD - 128x128 TFT 12 bit color with backlight.

EXTERNAL CONNECTORS DESCRIPTION:

UEXT:

Pin #	Signal Name
1	VCC
2	GND
3	UTXD1
4	URXD1
5	SCL
6	SDA
7	SDI
8	SDO
9	CLK
10	UEXT_CS

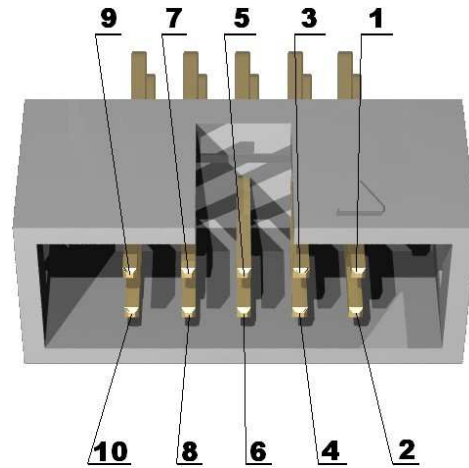

JTAG:

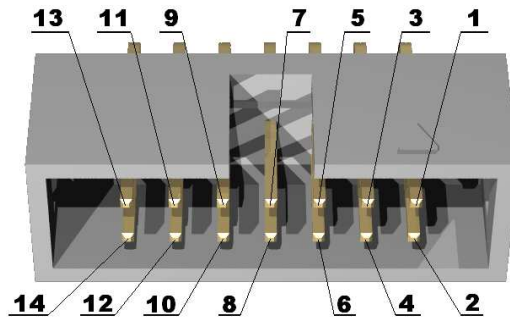

Pin #	Signal Name	Pin #	Signal Name
1	TDO/TDI	2	Via JMP PIN to VCC
3	TDI	4	Via JMP POUT to VCC
5	TMS	6	Not Connected
7	TCK	8	Not Connected
9	GND	10	Not Connected

11	RST	12	Not Connected
13	Not Connected	14	Not Connected

PWR 3V:

Pin #	Signal Name
1	VCC
2	GND

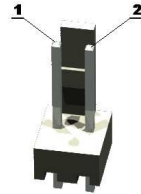

SD/MMC:

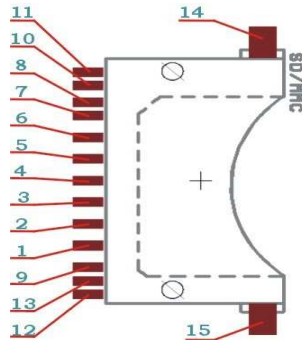

Pin #	Signal Name	Pin #	Signal Name
1	STE	2	SIMO/SDA
3	GND	4	VCC
5	UCLK	6	GND
7	SOMI/SCL	8	Via R10 (100k) to VCC
9	Via R9 (100k) to VCC	10	WP
11	Via R6 (2k) to GND	12	Via R8 (10k) to GND
13	CP	14	Via R6 (2k) to GND
15	Via R8 (10k) to GND		

IRDA:

Pin #	Signal Name
-------	-------------

1	ired_anode
2	Not Connected
3	IRDA_TX
4	IRDA_RX
5	Not Connected
6	IRDA power supply
7	Sensitivity Control
8	GND



EXT1:

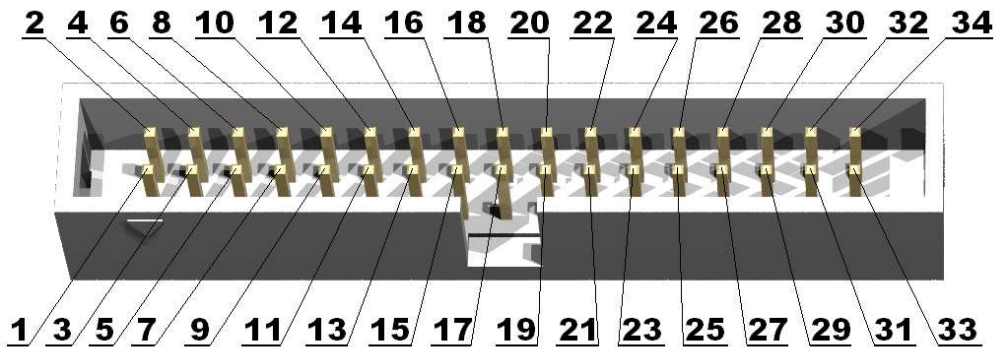

Pin #	Signal Name	Pin #	Signal Name
1	GND	2	VCC
3	P10.6	4	P10.7
5	P5.0	6	P5.1
7	P6.3	8	P6.4
9	P6.5	10	P6.6
11	VREF+	12	VEREF+
13	V+	14	GND
15	P1.1	16	P1.2
17	P1.3	18	P1.4
19	P1.5	20	P2.0
21	P2.1	22	P2.2
23	STE	24	SIMO/SDA
25	SIMO/SCL	26	UCLK
27	P3.4	28	P3.5

29	P3.6	30	P3.7
31	UTXD1	32	URXD1
33	P4.4	34	RST

EXT2:

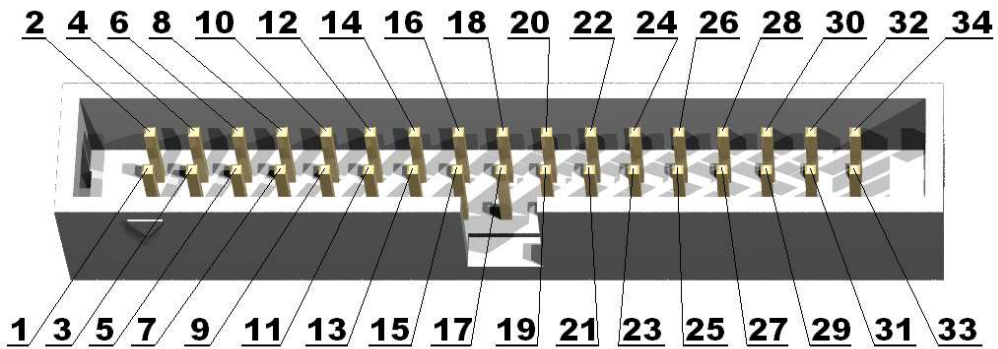

Pin #	Signal Name	Pin #	Signal Name
1	GND	2	VCC
3	LCDCAP	4	P5.7
5	P5.6	6	P5.5
7	P5.4	8	P5.3
9	P5.2	10	COM0
11	P2.3	12	P2.4
13	P2.5	14	P2.7
15	UEXT_CS	16	P8.4
17	P8.5	18	P8.6
19	P8.7	20	P9.0
21	P9.1	22	P9.2
23	P9.3	24	P9.4
25	P9.5	26	P9.6
27	P9.7	28	P10.0
29	P10.1	30	P10.2
31	P10.3	32	P10.4
33	P10.6	34	GND

MECHANICAL DIMENSIONS:

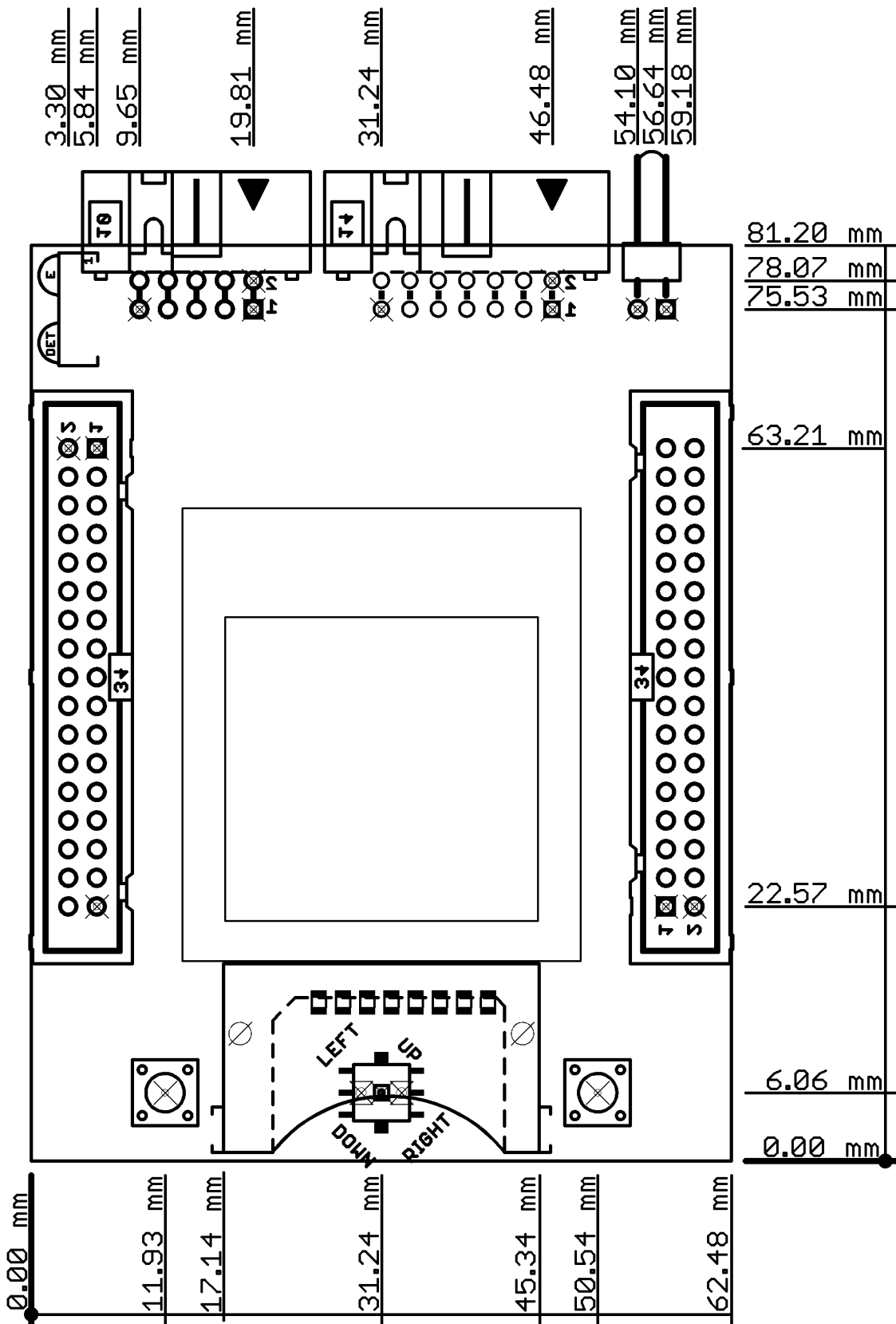

AVAILABLE DEMO SOFTWARE:

- [MSP430-4619LCD demo code](#) for GE12 LCD controller - ball moved by the accelerometer with pan and tilt of the board, the demo code supports both GE8 and GE12 LCD displays, define which one is on your board in LCD.H
- [MSP430-4619LCD demo code](#) - same for GE08 LCD controller
- [MSP430-4619LCD demo](#)
- [MSP430-4619LCD web page](#) from our customer Peter Ivanov
- Jim Lynch's [NOKIA 6610 LCD tutorial](#)

ORDER CODE:

MSP430-4619LCD - assembled and tested board

How to order?

You can order to us directly or by any of our distributors.
Check our web www.olimex.com/dev for more info.

Revision history:

Board's revision:	Rev. B, March 2011
Manual's revision:	Rev. Initial, June 2011

Disclaimer:

© 2011 Olimex Ltd. All rights reserved. Olimex®, logo and combinations thereof, are registered trademarks of Olimex Ltd. Other terms and product names may be trademarks of others.

The information in this document is provided in connection with Olimex products. No license, express or implied or otherwise, to any intellectual property right is granted by this document or in connection with the sale of Olimex products.

Neither the whole nor any part of the information contained in or the product described in this document may be adapted or reproduced in any material from except with the prior written permission of the copyright holder.

The product described in this document is subject to continuous development and improvements. All particulars of the product and its use contained in this document are given by OLIMEX in good faith. However all warranties implied or expressed including but not limited to implied warranties of merchantability or fitness for purpose are excluded.

This document is intended only to assist the reader in the use of the product. OLIMEX Ltd. shall not be liable for any loss or damage arising from the use of any information in this document or any error or omission in such information or any incorrect use of the product.