

## PIC-P67J60 development board

## Users Manual

Rev. C, December 2009  
Copyright(c) 2009, OLIMEX Ltd, All rights reserved

## INTRODUCTION:

If you want to build your own Internet enabled device this is the board for you. It has PIC18F67J60 microcontroller which has integrated Ethernet MAC+PHY and comes pre-programmed with Microchip's free TCP-IP stack. So all you need is to add your circuit in the prototype area and you are ready! With 128K Flash memory for programs and 128KB Flash memory your application will not suffer from low memory at all.

## BOARD FEATURES:

- **PIC18F67J60** microcontroller with Ethernet and 1Mbit memory for code;
- 1Mbit data Flash for data storage;
- mini ICSP/ICD connector for programming with PIC-ICD2;
- Ethernet connector with status leds;
- RS232 driver and connector;
- Complete web server and TCP-IP stack support as per Microchip's open source TCP-IP stack;
- All PIC free ports available on header close to the prototype area;
- Dimensions 100x80 mm (3.94 x 3.4");

## ELECTROSTATIC WARNING:

The **PIC18F67J60** development board is shipped in protective anti-static packaging. The board must not be subject to high electrostatic potentials. General practice for working with static sensitive devices should be applied when working with this board.

## BOARD USE REQUIREMENTS:

**Cables:** 1.8 meter USB A-B cable to connect PIC-ICD2 or PIC-ICD2-POCKET to USB host on PC, or RS232 cable, if you use PIC-ICD2-TINY. Other cables might be required in case of other programming/debugging tools. You will need a serial cable if not for programming, than for configuring the board. You will also need a LAN cable.

**Hardware:** Programmer/Debugger – **PIC-ICD2, PIC-ICD2-POCKET, PIC-ICD2-TINY** or other compatible programming/debugging tool.

**!!!Warning!!!** When you want to program this microcontroller with PIC-ICD2, PIC-ICD2-POCKET or PIC-ICD2-TINY, before connecting the programmer to your target board, you should first connect the programmer to your computer and open MPLAB. There, first from menu Configure – Select Device – choose the microcontroller you are about to program, then from menu Programmer – Select Programmer – choose MPLAB ICD 2, wait while MPLAB is downloading operation system, and after ICD2 is connected – check in menu Programmer – Settings – Power – there is option – Power target circuit from MPLAB ICD 2 – this



- Auto-wake-up on Start bit
- Auto-Baud Detect (ABD)
  - 10-Bit, Up to 16-Channel Analog-to-Digital Converter module (A/D):
- Auto-acquisition capability
- Conversion available during Sleep
  - Dual Analog Comparators with Input Multiplexing
  - 5.5V Tolerant Inputs (digital-only pins)
  - Low-Power, High-Speed CMOS Flash Technology:
- Self-reprogrammable under software control
  - C compiler Optimized Architecture for Reentrant Code
  - Power Management Features:
- Run: CPU on, peripherals on
- Idle: CPU off, peripherals on
- Sleep: CPU off, peripherals off
  - Priority Levels for Interrupts
  - 8 x 8 Single-Cycle Hardware Multiplier
  - Extended Watchdog Timer (WDT):
    - Programmable period from 4 ms to 134s
  - Single-Supply 3.3V In-Circuit Serial Programming (ICSP™) via Two Pins
  - In-Circuit Debug (ICD) with 3 Breakpoints via Two Pins
  - Operating Voltage Range of 2.35V to 3.6V (3.1V to 3.6V using Ethernet module)
  - On-Chip 2.5V Regulator

# BLOCK DIAGRAM

FIGURE 1-1: PIC18F66J60/66J65/67J60 (64-PIN) BLOCK DIAGRAM

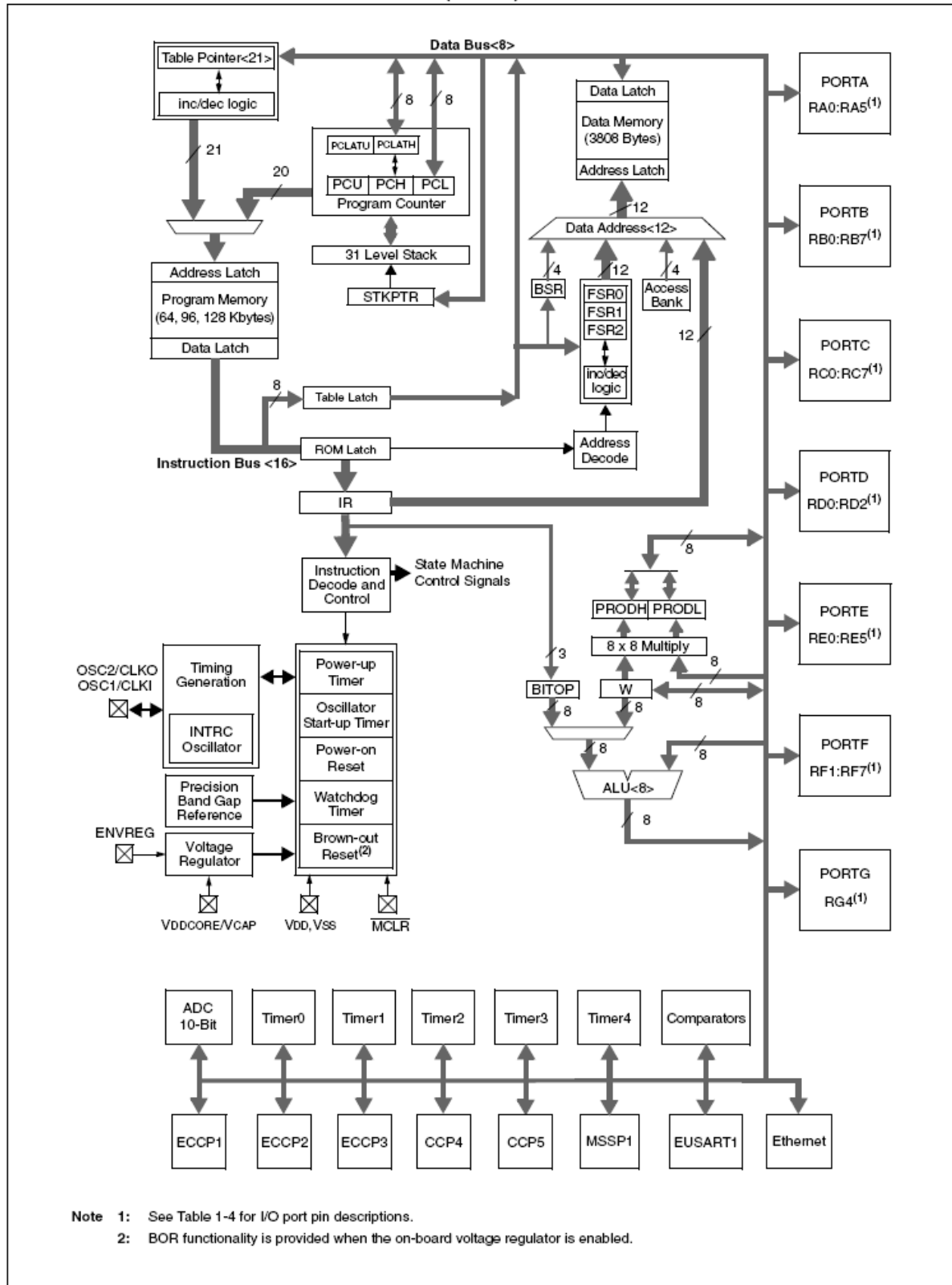

# MEMORY MAP:

DATA MEMORY MAP FOR PIC18F97J60 FAMILY DEVICES

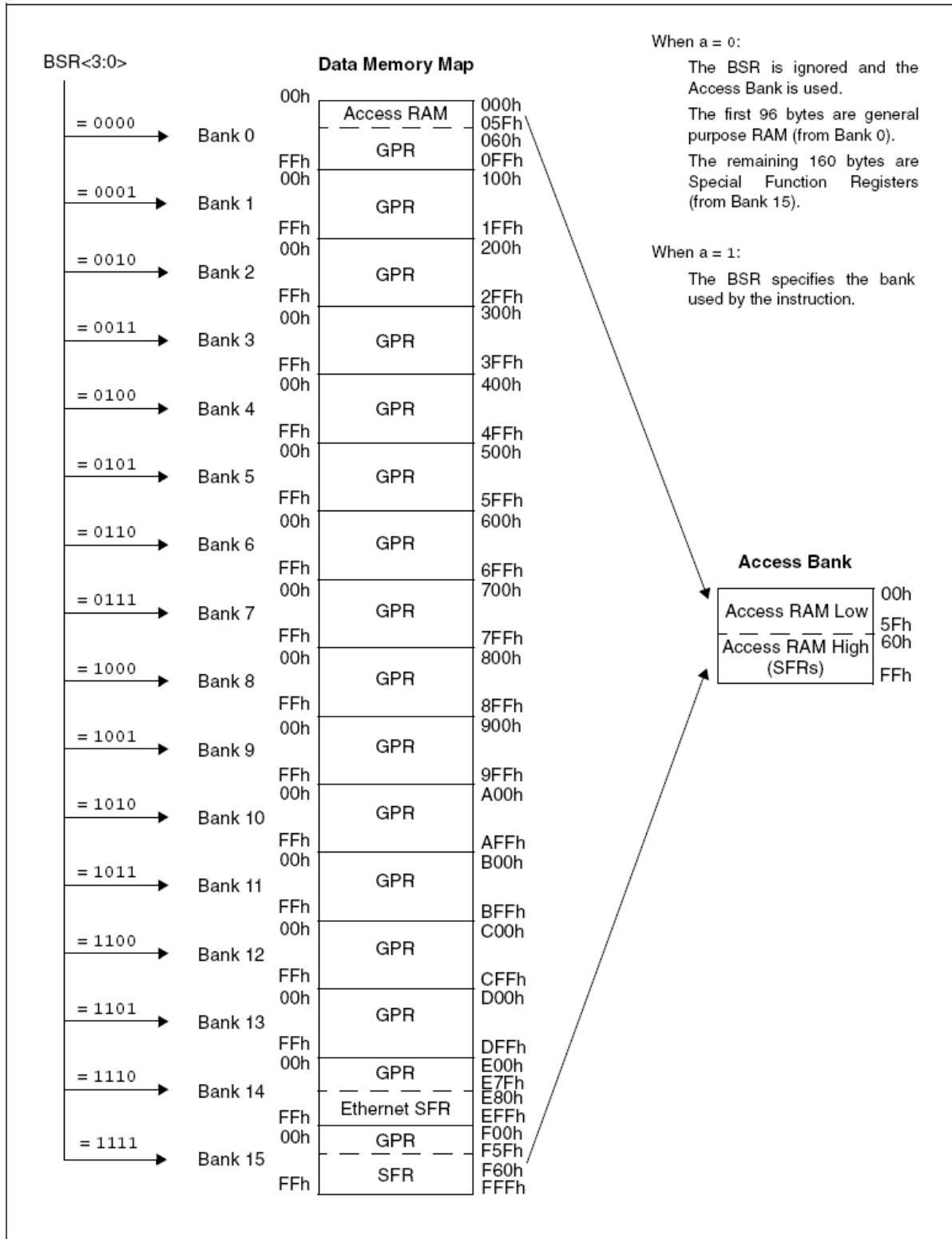

**FIGURE 5-1: MEMORY MAPS FOR PIC18F97J60 FAMILY DEVICES**

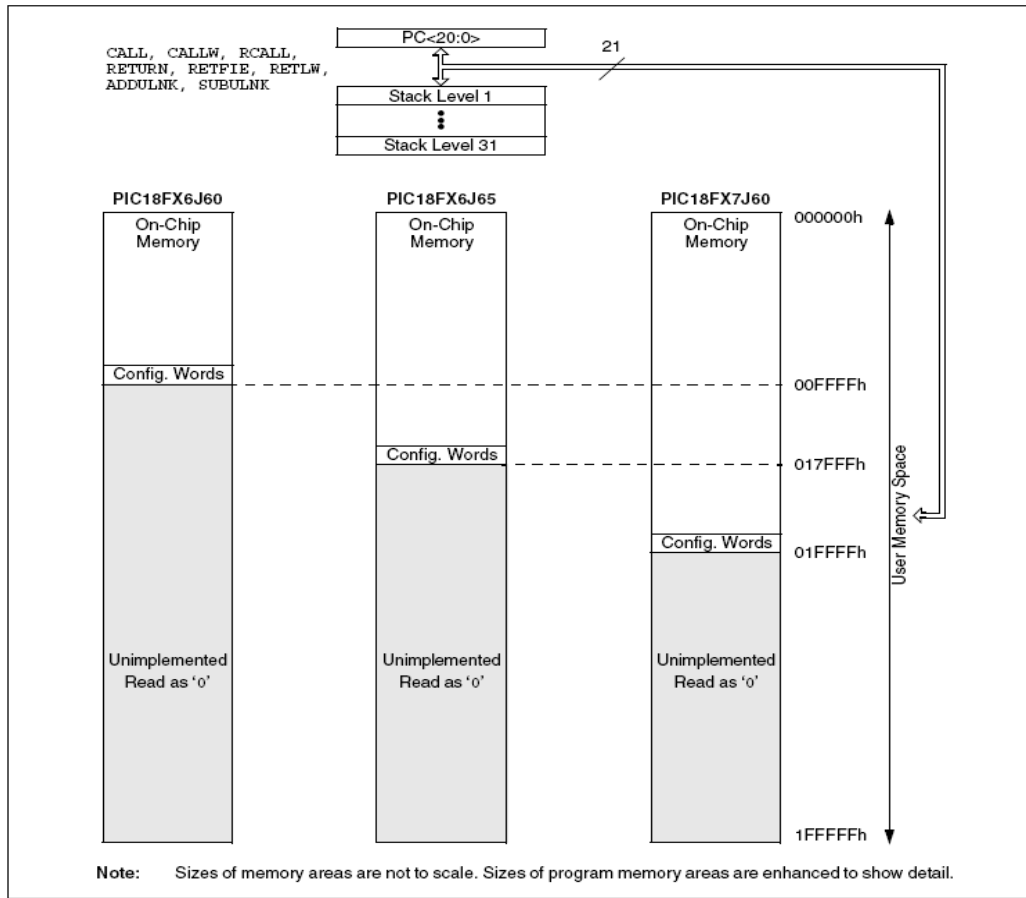

## MEMORY MAPS FOR PIC18F97J60 FAMILY PROGRAM MEMORY MODES

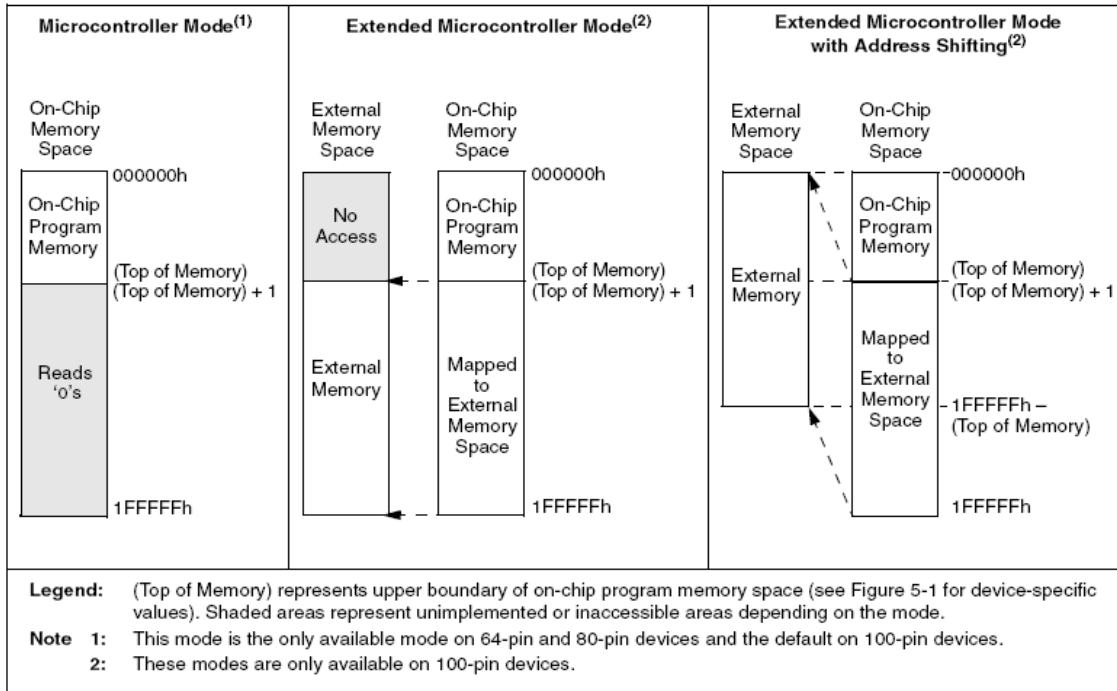



# SCHEMATIC:

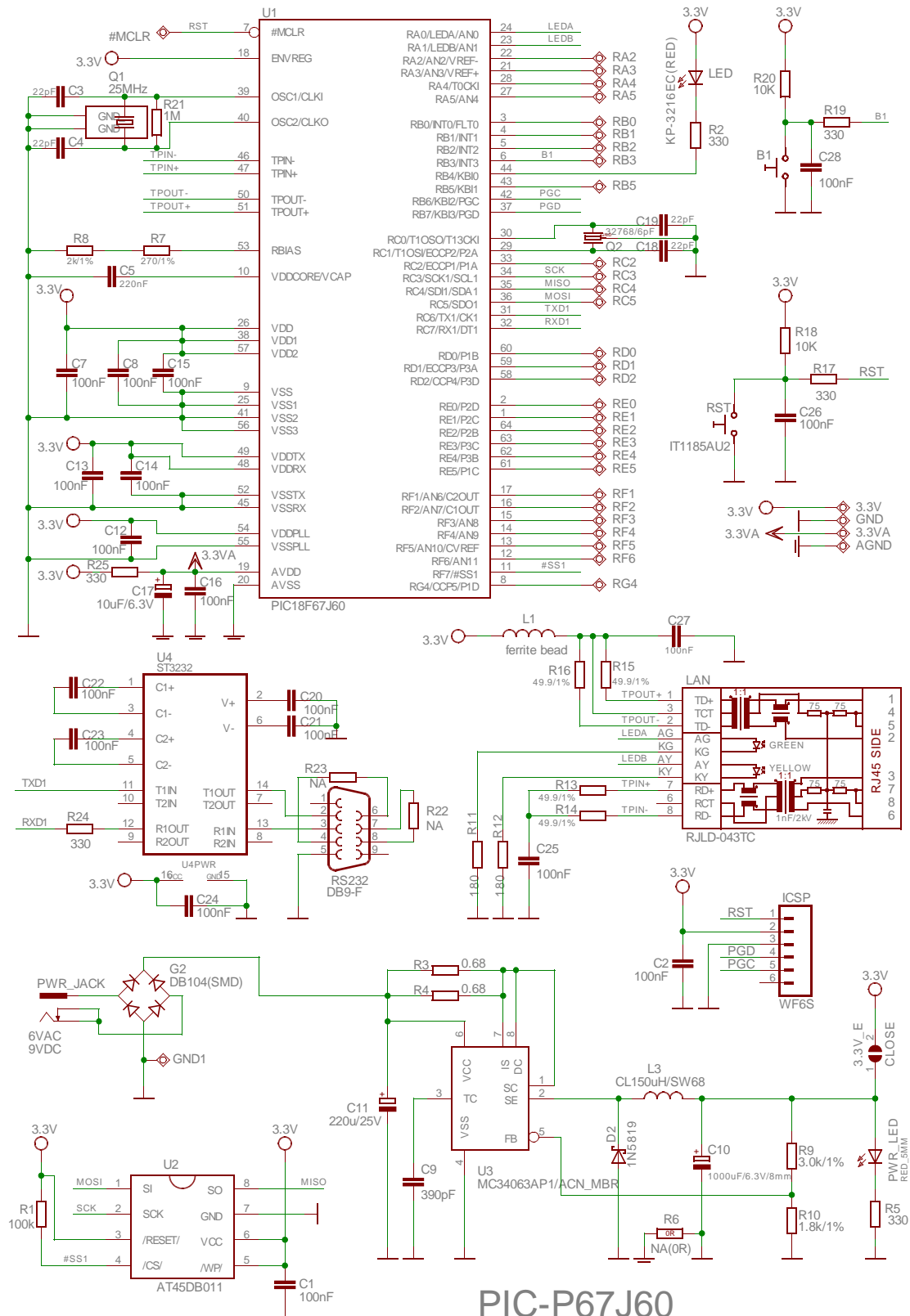

## PIC-P67J60

Rev. B  
 COPYRIGHT(C) 2009, Olimex Ltd.  
<http://www.olimex.com/dev>

## BOARD LAYOUT:

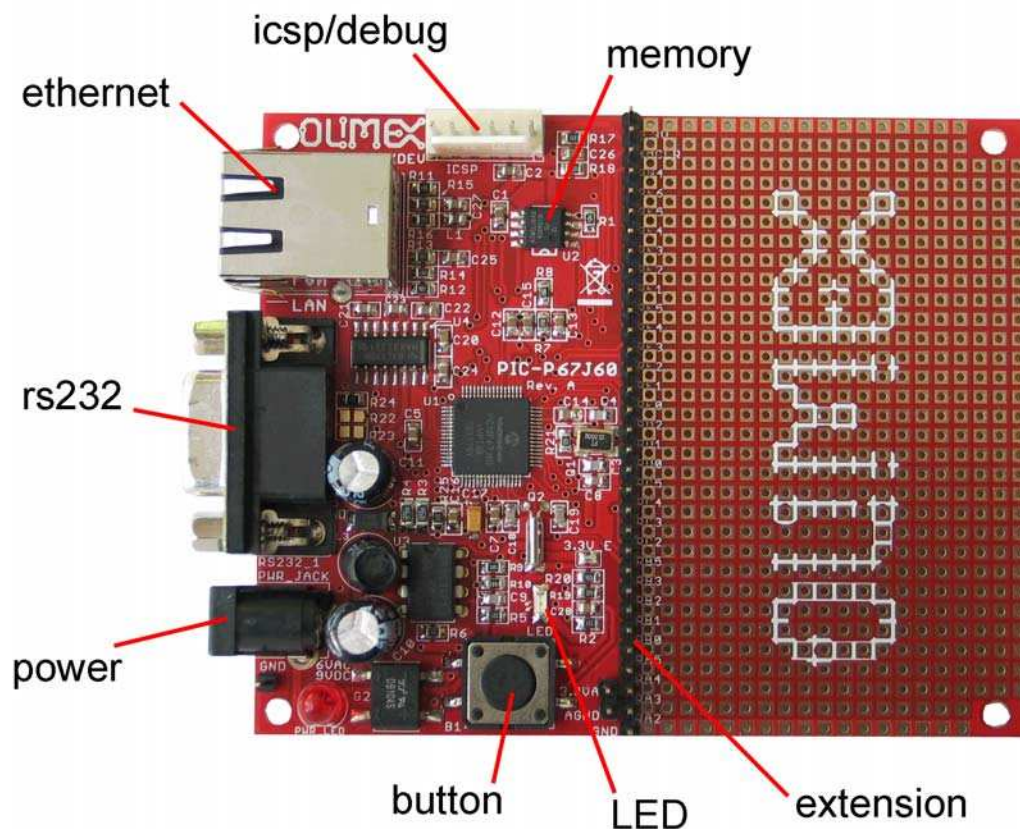

## POWER SUPPLY CIRCUIT:

**PIC-P67J60** can take power only from power connector PWR, where (9-12) VDC or 6VAC external power supply have to be applied.

The board power consumption is: about 80 mA with all peripherals and MCU running at full speed.

## RESET CIRCUIT:

**PIC-P67J60** reset circuit is made with the pull-up R18 (10K), R17 (330 $\Omega$ ) and C31 (100nF).

## CLOCK CIRCUIT:

Quartz crystal 25 MHz is connected to **PIC18F67J60** pin 39 clock in (OSC1/CLKI) and pin 40 clock out (OSC2/CLKO).

Quartz crystal 32.768 kHz is connected to **PIC18F67J60** pin 29 (T1OSI) and pin 30 (T1OSO) and supplies the Timer1.

## JUMPER DESCRIPTION:

3.3V\_E



enables 3.3 V power supply for the **PIC18F67J60** and all other devices.

Default state is closed.

## INPUT/OUTPUT:

One **user button** with name **BUT1** – connected to PIC18F67J60 pin 6 RB3/INT3;

One **LED** named **LED**(red) connected to PIC18F67J60 pin 44 RB4/KBIO;

**Power supply red LED** with name **PWR\_LED** – indicates that power supply 3.3V is present.

**EXTERNAL CONNECTOR DESCRIPTION:**

**PWR:**

Pin #	Signal Name
1	9VDC or 6VAC
2	GND

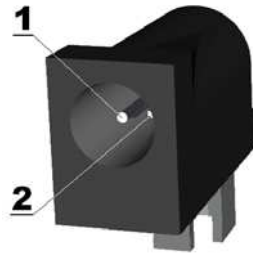

The power input should be +9VDC/6VAC.

**ICSP:**

Pin #	Signal Name
1	RST
2	VCC
3	GND
4	PGD
5	PGC
6	NC

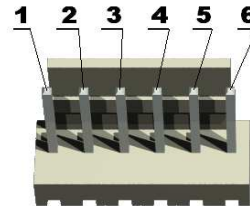

**PGD** I/O **Program Data.** Serial data for programming.

**PGC** Input **Program Clock.** Clock used for transferring the serial data (output from ICSP, input for the MCU).

**RS232:**

Pin #	Signal Name
1	NC
2	TXD
3	RXD
4	to pin 6 via R23/NC
5	GND

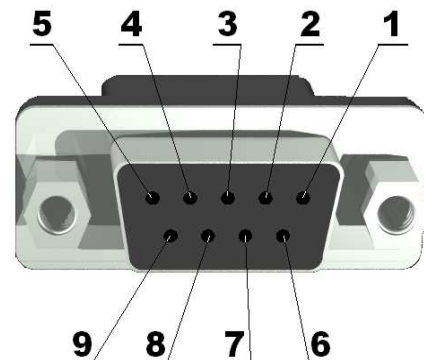

6	to pin 4 via R23/NC
7	to pin 8 via R22/NC
8	to pin 7 via R22/NC
9	NC

**TXD** Output **Transmit Data**. This is the asynchronous serial data output (RS232) for the shift register on the UART controller.

**RXD** Input **Receive Data**. This is the asynchronous serial data input (RS232) for the shift register on the UART controller.

**LAN:**

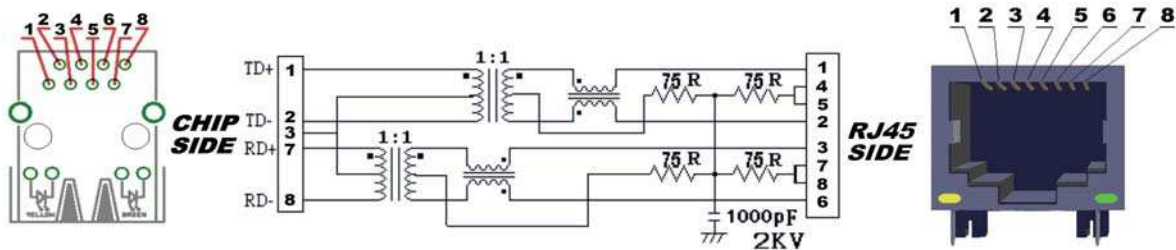

Pin #	Signal Name Chip Side	Pin #	Signal Name Chip Side
1	TPOUT+	5	Not Connected (NC)
2	TPOUT-	6	Not Connected (NC)
3	3.3V	7	TPIN+
4	Not Connected (NC)	8	TPIN-

LED	Color	Usage
Right	Yellow	Activity
Left	Green	100Mbits/s (Half/Full duplex)

## PROTOAREA:

Pin #	Signal Name
3.3V	3.3V
#MCLR	RST
RG4	RG4/CCP5/P1D
RF6	RF6/AN11
RF5	RF5/AN10/CVREF
RF4	RF4/AN9
RF3	RF3/AN8
RF2	RF2/AN7/C1OUT
RF1	RF1/AN6/C2OUT
RE5	RE5/P1C
RE4	RE4/P3B
RE3	RE3/P3C
RE2	RE2/P2B
RE1	RE1/P2C
RE0	RE0/P2D
RD2	RD2/CCP4/P3D
RD1	RD1/ECCP3/P3A
RD0	RD0/P1B
RC5	RC5/SDO1/MOSI
RC4	RC4/SDI1/SDA1/MISO
RC3	RC3/SCK1/SCL1/SCK
RC2	RC2/ECCP1/P1A
RB5	RB5/KBI0
RB3	RB3/INT3/B1
RB2	RB2/INT2
RB1	RB1/INT1
RB0	RB0/INT0/FLT0
RA5	RA5/AN4
RA4	RA4/TOCKI
RA3	RA3/AN3/VREF+
RA2	RA2/AN2/VREF-
3.3VA	3.3V ANALOG
AGND	ANALOG GND

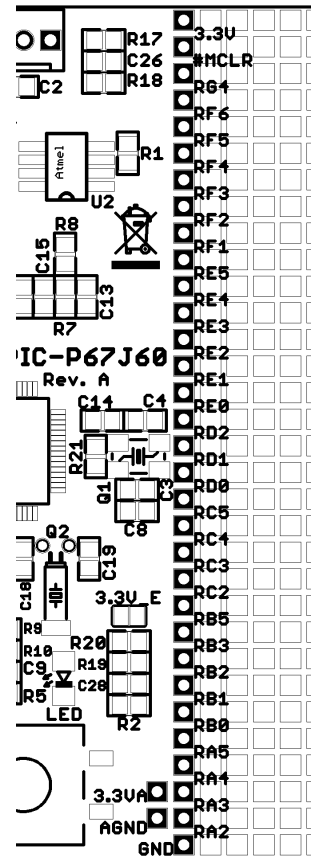

**MECHANICAL DIMENSIONS:**

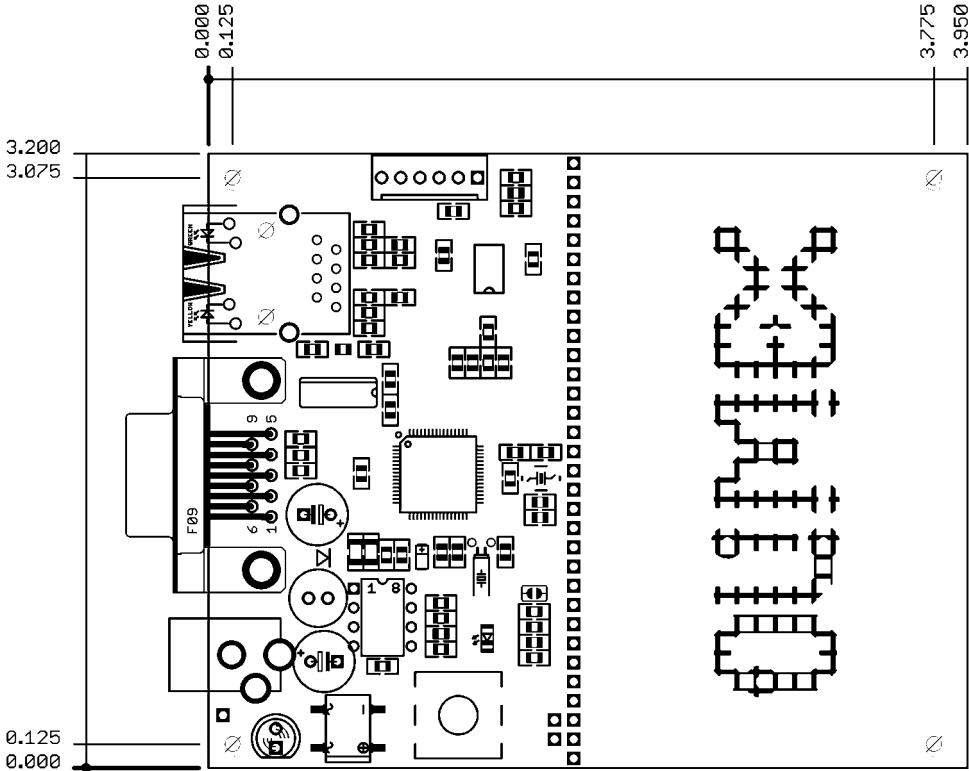

All dimensions are in inches.

## AVAILABLE DEMO SOFTWARE:

You could find information about PIC-P67J60 board, Microchip TCP/IP stack and how to change and configure the software in **Understanding PIC WEB boards** on [www.olimex.com/dev](http://www.olimex.com/dev).



## **ORDER CODE:**

**PIC-P67J60** – completely assembled and tested with PIC18F67J60 on board.

How to order?

You can order to us directly or by any of our distributors.

Check our web [www.olimex.com/dev](http://www.olimex.com/dev) for more info.



All boards produced by Olimex are RoHS compliant

## **Revision history:**

REV. B - created December 2009

**Disclaimer:**

© 2009 Olimex Ltd. All rights reserved. Olimex®, logo and combinations thereof, are registered trademarks of Olimex Ltd. Other terms and product names may be trademarks of others.

The information in this document is provided in connection with Olimex products. No license, express or implied or otherwise, to any intellectual property right is granted by this document or in connection with the sale of Olimex products.

Neither the whole nor any part of the information contained in or the product described in this document may be adapted or reproduced in any material from except with the prior written permission of the copyright holder.

The product described in this document is subject to continuous development and improvements. All particulars of the product and its use contained in this document are given by OLIMEX in good faith. However all warranties implied or expressed including but not limited to implied warranties of merchantability or fitness for purpose are excluded.

This document is intended only to assist the reader in the use of the product. OLIMEX Ltd. shall not be liable for any loss or damage arising from the use of any information in this document or any error or omission in such information or any incorrect use of the product.