

## **PIC-USB-4550 development board**

## **Users Manual**

Rev.A, June 2007

Copyright(c) 2007, OLIMEX Ltd, All rights reserved

## **INTRODUCTION:**

PIC-USB-4550 board is development board, which allow you to prototype and develop USB applications with PIC18F4550 microcontrollers.

What you can do with PIC-USB-4550? Let's see what we have:

PIC-USB-4550 have USB connector to connect and interface with PC or other USB host. Microchip provide free firmware for USB HID (human interface device) device which you can use to make custom mouse, joystick, CDC (communication class device), Audio class device (make your own microphone, speaker etc USB devices), Mass storage device (add your own USB disks), USB to RS232 etc etc. Using the Microchip bootloader you can program your code and change your firmware via USB without the need for programmer!

The on-board ICSP connector allow you to program the PIC on the board without pulling it of the socket, by ICSP programmer like PIC-MCP, PIC-MCP-USB, PIC-PG1, PIC-PG2, PIC-PG3, PIC-PG4 or to program and debug it with PIC-ICD2, PIC-ICD2-POCKET or PIC-ICD2-TINY.

PIC-USB-4550 can be powered from the USB or from external source. This is jumper selectable. When the board is powered from the USB your power budget is 5V/100mA i.e. your circuit should not exceed this power. If your circuit need more power you can connect external power supply. The external power supply circuit have diode bridge after the power supply jack which allow you to power this board with both AC and DC power supply adapters. The input voltage could be anything within the range +7.5 – 15V DC or 6-12V AC.

The oscillator circuit is made with 20 Mhz crystal oscillator, so you can run your PIC at maximum performance.

The RESET circuit is made with simple RC circuit and RESET push button.

PIC-USB-4550 have user button for user input connected to PIC microcontroller's RC4 port. When RC4 port is initialized as INPUT you will read "0" when the button is pressed and "1" when it is depressed. This button also is used to enter BOOTLOADER programming mode.

Status LED is connected via jumper to PIC microcontroller's RD3 port. When your RD3 port is initialized as OUTPUT and set to "0" LED will go ON, when RD3 port is set to "1" LED will go OFF.

## FEATURES:

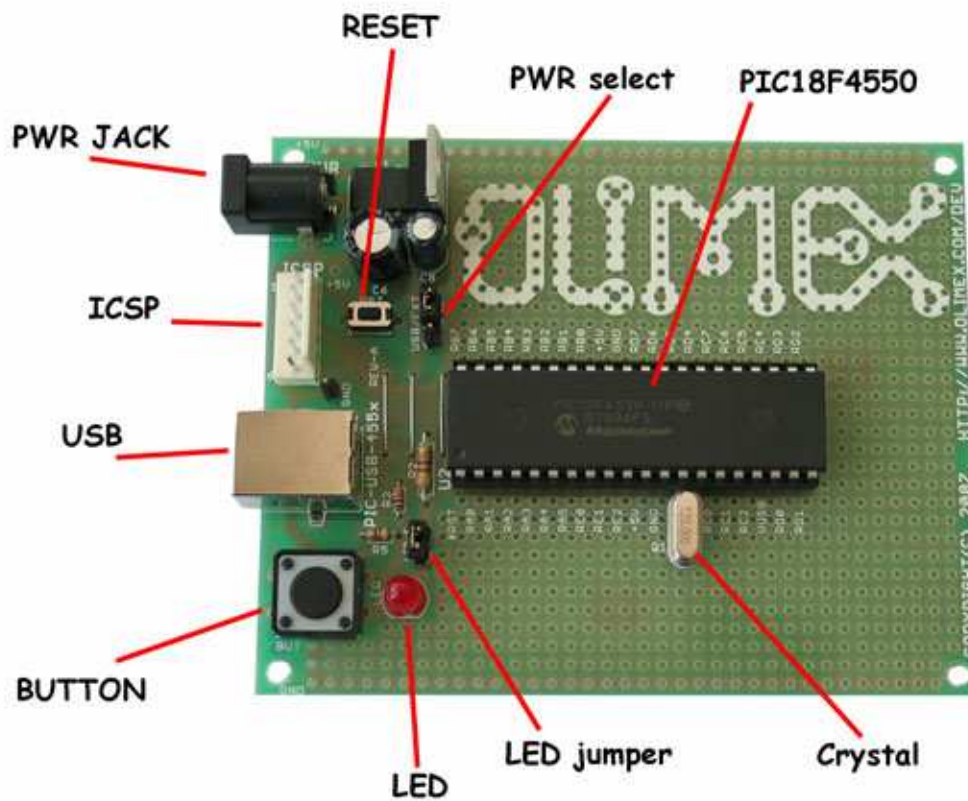

- ICSP/ICD connector for programming with PIC-MCP, PIC-MCP-USB, PIC-PG1, PIC-PG2, PIC-PG3 or PIC-PG4 and programming and debugging with PIC-ICD2, PIC-ICD2-POCKET, PIC-ICD2-TINY
- USB 2.0 type B connector allows board to be interfaced to PC host.
- PIC18F4550-I/P on DIL40 socket
- Quartz crystal 20Mhz
- LED connected to RD3 through jumper
- user Button connected to RB4
- Reset button
- Power plug-in jack with diode bridge can be powered with AC or DC power supply
- 5V voltage regulator
- Extension slot on every uC pin
- Grid 100 mils
- GND bus
- Vcc bus
- Four mounting holes 3,3 mm (0,13")
- FR-4, 1.5 mm (0,062"), green soldermask, white silkscreen component print
- Dimensions 100x80 mm (3,9x3,15")



All boards produced by Olimex are ROHS compliant

# HARDWARE:

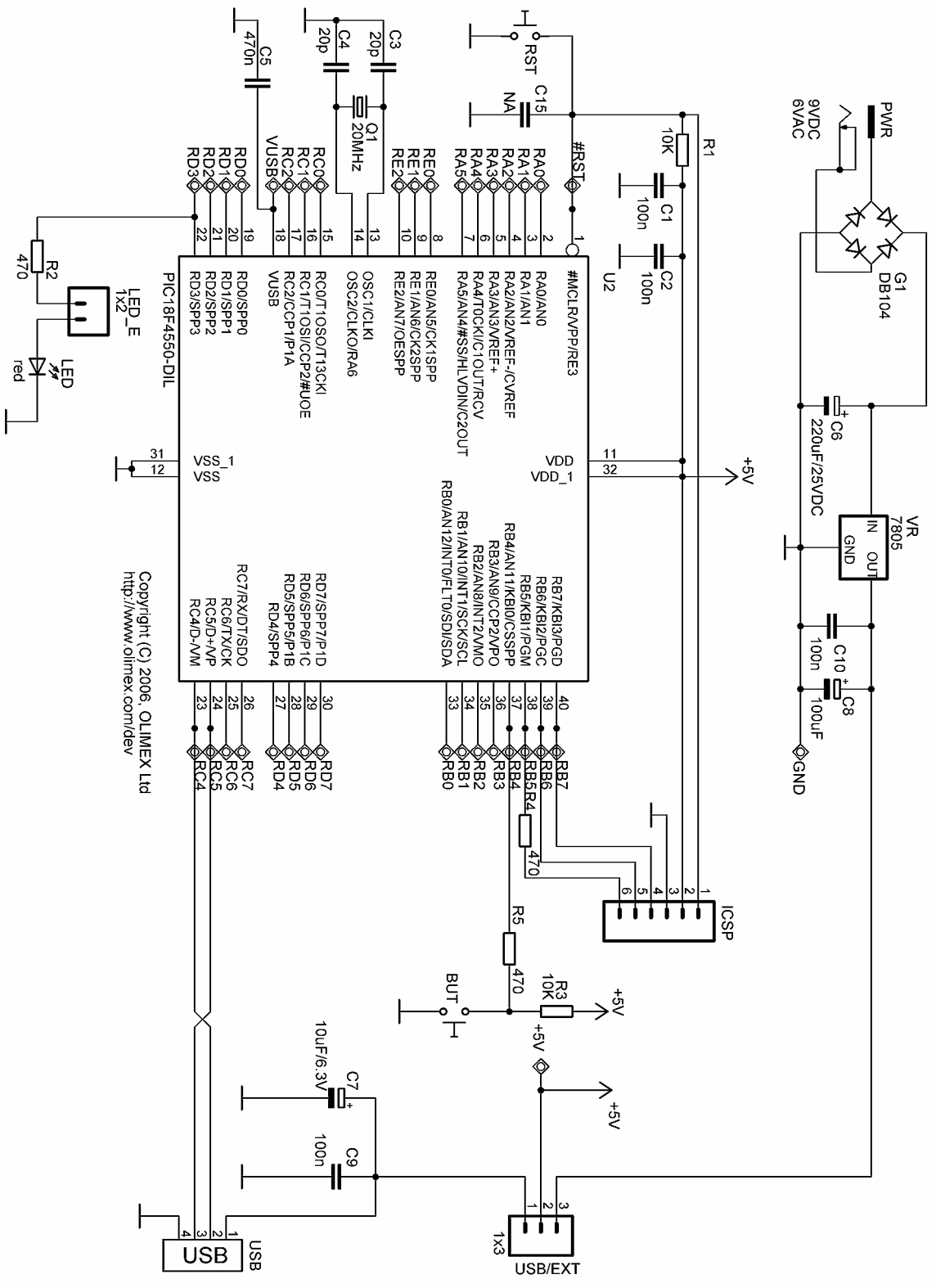

## **SOFTWARE:**

USB bootloader

USB HID mouse

Blink LED

## **ORDER CODE:**

**PIC-USB-4550** – assembled and tested with PIC18F4550-I/P (no kit, no soldering required)

**PIC-USB-4550/PCB** – blank PCBs only

**How to order?**

**You can order to us directly or by any of our distributors.**

**Check our web [www.olimex.com/dev](http://www.olimex.com/dev) for more info.**

**Disclaimer:**

© 2007 Olimex Ltd. All rights reserved. Olimex®, logo and combinations thereof, are registered trademarks of Olimex Ltd. Other terms and product names may be trademarks of others.

The information in this document is provided in connection with Olimex products. No license, express or implied or otherwise, to any intellectual property right is granted by this document or in connection with the sale of Olimex products.

Neither the whole nor any part of the information contained in or the product described in this document may be adapted or reproduced in any material from except with the prior written permission of the copyright holder.

The product described in this document is subject to continuous development and improvements. All particulars of the product and its use contained in this document are given by OLIMEX in good faith. However all warranties implied or expressed including but not limited to implied warranties of merchantability or fitness for purpose are excluded.

This document is intended only to assist the reader in the use of the product. OLIMEX Ltd. shall not be liable for any loss or damage arising from the use of any information in this document or any error or omission in such information or any incorrect use of the product.