



# PIC-MICRO-WEB development board Users Manual

Rev. D, April 2011

Copyright(c) 2011, OLIMEX Ltd, All rights reserved

## INTRODUCTION:

This small and compact board will give you the opportunity to add Internet connectivity to any of your existing design or machine. Packed in compact plastic enclosure with DB25 male connector for the microcontroller ports and with the unique PoE (Power over Ethernet) feature which allows PIC-MICRO-WEB to take power by the Ethernet cable and with no need for external power supply adapter. The TCP-IP stack provided by Microchip is free of charge and royalties and allows you to do http, ftp, e-mail etc services. You can control the PIC GPIOs by web interface and to acquire and send data from external sensors to other Internet applications and clients. With 128K Flash memory for programs and 128KB Flash memory for web storage this small device have all resources usually needed for general embedded Internet applications and interface of sensors and machines to Internet.

## BOARD FEATURES:

- PIC18F67J60 microcontroller with Ethernet and 1 Mbit memory for code
- 1Mbit on board serial flash for web pages storage
- mini ICSP/ICD connector for programming with PIC-ICD2, PIC-ICD2-TINY and PIC-ICD2-POCKET.
- Power-Over-Ethernet support (for use with MOD-PoE power supply injector on standard LAN cables/switches)
- It is possible to use the board without PoE in which case DB25.pin8 (Vin) should be connected to 10-50 VDC source
- The board is enclosed in plastic shell DB25 parallel port
- 25 available signals and power supply on the DB25 connector
- Dimensions 50x30 mm (2 x 1.2")

## ELECTROSTATIC WARNING:

The PIC-MICRO-WEB board is shipped in protective anti-static packaging. The board must not be subject to high electrostatic potentials. General practice for working with static sensitive devices should be applied when working with this board.

## BOARD USE REQUIREMENTS:

- Cables:** 1.8 meter USB A-B cable to connect PIC-ICD2 or PIC-ICD2-POCKET to USB host on PC or RS232 cable for PIC-ICD2-TINY. Other cables might be required in case of other programming/debugging tools. You will also need a LAN cable.
- Hardware:** Programmer/Debugger – PIC-ICD2, PIC-ICD2-POCKET, PIC-ICD2-TINY or other compatible programming/debugging tool. MOD-PoE – module that provides Power-Over-Ethernet. If you don't want to use this module, you should apply power (10-50VDC) directly to DB25.pin8.

**!!!Warning!!!** When you want to program this microcontroller with PIC-ICD2, PIC-ICD2-POCKET or PIC-ICD2-TINY, before connecting the programmer to your target board, you should first connect the programmer to your computer and open MPLAB. There, first from menu Configure – Select Device – choose the microcontroller you are about to program, then from menu Programmer – Select Programmer – choose MPLAB ICD 2, wait while MPLAB is downloading operation system, and after ICD2 is connected – check in menu Programmer – Settings – Power – there is option – Power target circuit from MPLAB ICD 2 – this option should be forbidden, you could not select it. Now it is safe to connect the programmer to your target board.

**Software:** PIC-MICRO-WEB is tested with **MPLAB IDE v.7.62 + MPLAB C18 C** compiler. It is possible that the stack might not function properly if used with later versions of MPLAB IDE.

## **PROCESSOR FEATURES:**

**PIC-MICRO-WEB** board use MCU **PIC18F67J60** from Microchip with these features:

- IEEE 802.3 compatible Ethernet Controller
- Integrated MAC and 10Base-T PHY
- 8-Kbyte Transmit/Receive Packet Buffer SRAM
- Supports One 10Base-T Port
- Programmable Automatic Retransmit on Collision
- Programmable Padding and CRC Generation
- Programmable Automatic Rejection of Erroneous Packets
- Activity Outputs for 2 LED Indicators
- Buffer:
  - o Configurable transmit/receive buffer size
  - o Hardware-managed circular receive FIFO
  - o Byte-wide random and sequential access
  - o Internal DMA for fast memory copying
  - o Hardware assisted checksum calculation for various protocols
- MAC:
  - o Support for Unicast, Multicast and Broadcast packets
  - o Programmable Pattern Match of up to 64 bytes within packet at user-defined offset
  - o Programmable wake-up on multiple packet formats
- PHY:
  - o Wave shaping output filter
- Selectable System Clock derived from Single 25 MHz External Source:
  - o 2.778 to 41.667 MHz
- Internal 31 kHz Oscillator
- Secondary Oscillator using Timer1 @ 32 kHz
- Fail-Safe Clock Monitor:
  - o Allows for safe shutdown if oscillator stops
- Two-Speed Oscillator Start-up
- High-Current Sink/Source: 25 mA/25 mA on PORTB and PORTC

- Five Timer modules (Timer0 to Timer4)
- Four External Interrupt pins
- Two Capture/Compare/PWM (CCP) modules
- Three Enhanced Capture/Compare/PWM (ECCP) modules:
  - o One, two or four PWM outputs
  - o Selectable polarity
  - o Programmable dead time
  - o Auto-shutdown and auto-restart
- Up to Two Master Synchronous Serial Port (MSSP) modules supporting SPI (all 4 modes) and I2C™ Master and Slave modes
- Up to Two Enhanced USART modules:
  - o Supports RS-485, RS-232 and LIN 1.2
  - o Auto-wake-up on Start bit
  - o Auto-Baud Detect (ABD)
- 10-Bit, Up to 16-Channel Analog-to-Digital Converter module (A/D):
  - o Auto-acquisition capability
  - o Conversion available during Sleep
- Dual Analog Comparators with Input Multiplexing
- Parallel Slave Port (PSP) module (100-pin devices only)
- 5.5V Tolerant Inputs (digital-only pins)
- Low-Power, High-Speed CMOS Flash Technology:
  - o Self-reprogrammable under software control
- C compiler Optimized Architecture for Reentrant Code
- Power Management Features:
  - o Run: CPU on, peripherals on
  - o Idle: CPU off, peripherals on
  - o Sleep: CPU off, peripherals off
- Priority Levels for Interrupts
- 8 x 8 Single-Cycle Hardware Multiplier
- Extended Watchdog Timer (WDT):
  - o Programmable period from 4 ms to 134s
- Single-Supply 3.3V In-Circuit Serial Programming™ (ICSP™) via Two Pins
- In-Circuit Debug (ICD) with 3 Breakpoints via Two Pins
- Operating Voltage Range of 2.35V to 3.6V (3.1V to 3.6V using Ethernet module)
- On-Chip 2.5V Regulator

# BLOCK DIAGRAM:

FIGURE 1-1: PIC18F66J60/66J65/67J60 (64-PIN) BLOCK DIAGRAM

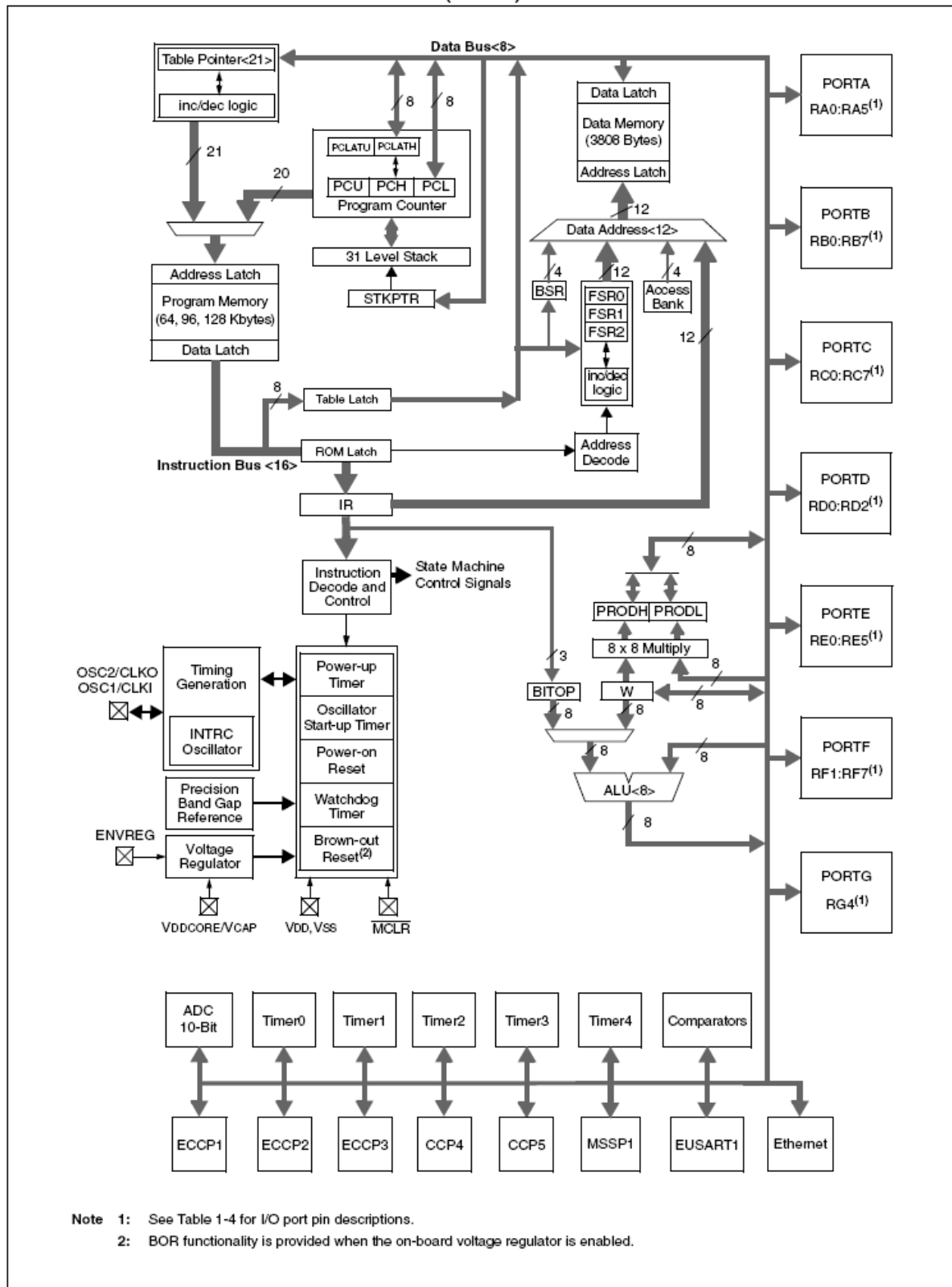

# MEMORY MAP:

DATA MEMORY MAP FOR PIC18F97J60 FAMILY DEVICES

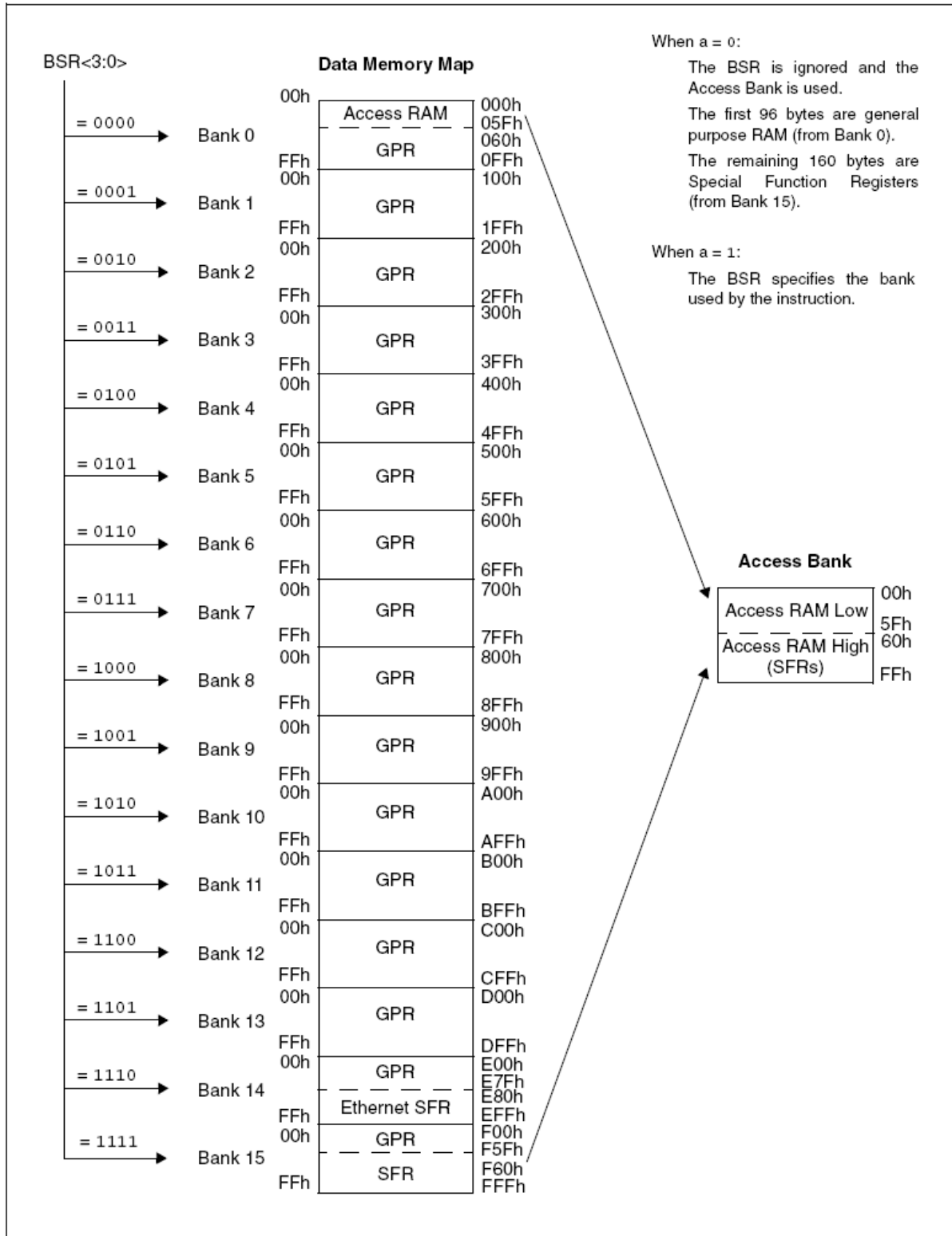
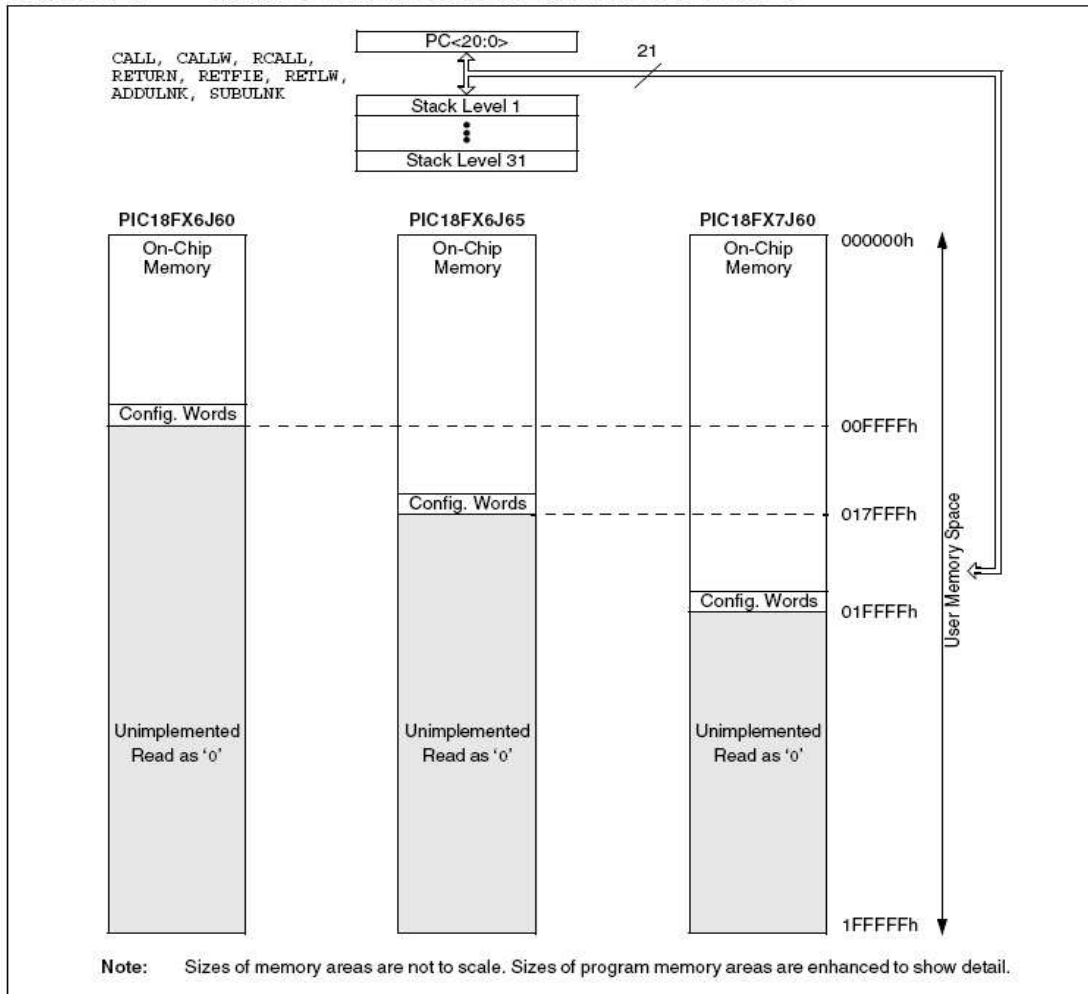
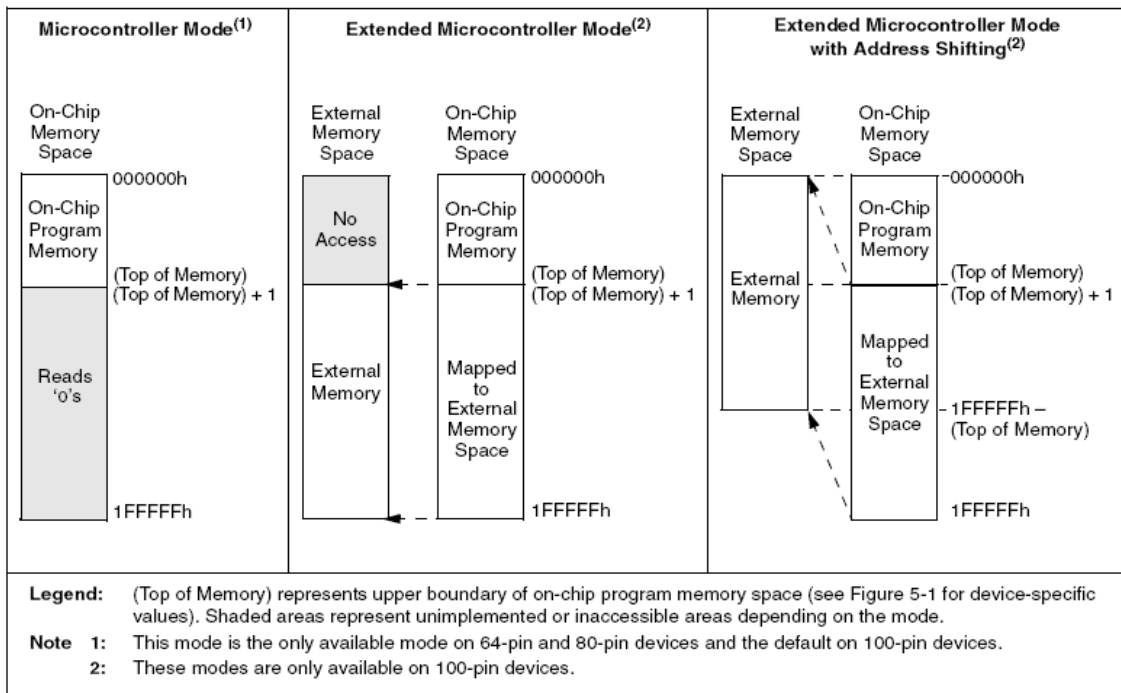
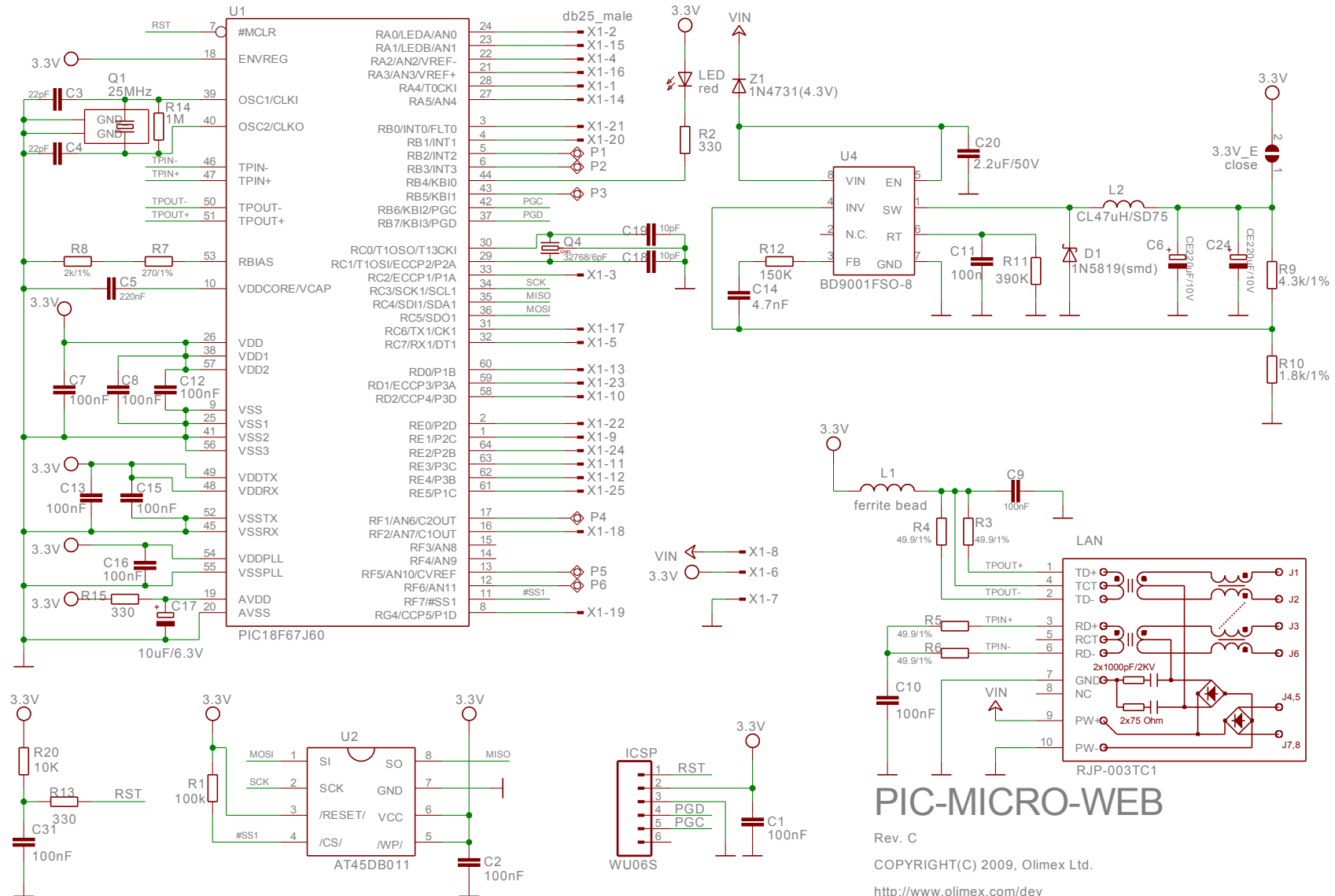

FIGURE 5-1: MEMORY MAPS FOR PIC18F97J60 FAMILY DEVICES



MEMORY MAPS FOR PIC18F97J60 FAMILY PROGRAM MEMORY MODES







## POWER SUPPLY CIRCUIT:

**PIC-MICRO-WEB** takes power over Ethernet using the module MOD-PoE. Other possibility is 24-50VDC to be directly applied to DB25.pin8 if MOD-PoE is not to be used.

The board power consumption depends on the applied power supply and may vary. At 24VDC the consumption is about 40 mA.

## RESET CIRCUIT:

**PIC-MICRO-WEB** reset circuit is made with R20 (10k) pull-up, R13 (330Ω) and capacitor C31 (100nF).

## CLOCK CIRCUIT:

Quartz crystal 25 MHz is connected to **PIC18F67J60** pin 39 clock in (OSC1/CLKI) and pin 40 clock out (OSC2/CLKO).

Quartz crystal 32.768 kHz is connected to **PIC18F67J60** pin 29 (T1OSI) and pin 30 (T1OSO) and supplies the Timer1.

## JUMPER DESCRIPTION:

3.3V\_E



enables 3.3 V power supply for the **PIC18F67J60** and all other devices.

Default state is closed.

## INPUT/OUTPUT:

Status red LED connected to PIC18F25J10 pin 44 (PORTB.RB4/KBI0).

## EXTERNAL CONNECTORS DESCRIPTION:

### ICSP:

Pin #	Signal Name
1	RST
2	+5V
3	GND
4	PGD
5	PGC
6	NC

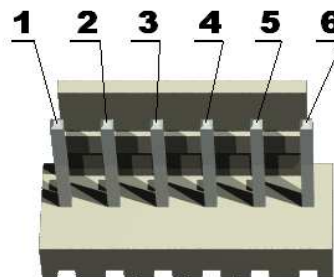

PGD I/O **Program Data.** Serial data programming.

PGC Input **Program Clock.** Clock used for transferring the serial data (output from ICSP, input for the MCU).

for

## DB25:

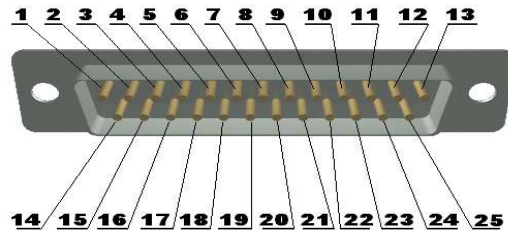

Pin #	Signal Name	Pin #	Signal Name
1	RA4/T0CKI	2	RA0/LEDA/ AN0
3	RC2/ECCP1/P1A	4	RA2/AN2/VREF-
5	RC7/RX1/DT1	6	VCC +3.3V
7	GND	8	VIN
9	RE1/P2C	10	RD2/CCP4/P3D
11	RE3/P3C	12	RE4/P3B
13	RD0/P1B	14	RA5/AN4
15	RA1/LEDB/AIN1	16	RA3/AN3/VREF+
17	RC6/TX1/CK1	18	RF2/ AN7/C1OUT
19	RG4/CCP5/P1D	20	RB1/INT1
21	RB0/INT0/FLT0	22	RE0/P2D
23	RD1/ECCP3/P3A	24	RE2/P2B
25	RE5/P1C		

VIN is the pin where you should apply 10-50VDC in case you don't want to use MOD-PoE.

## LAN:

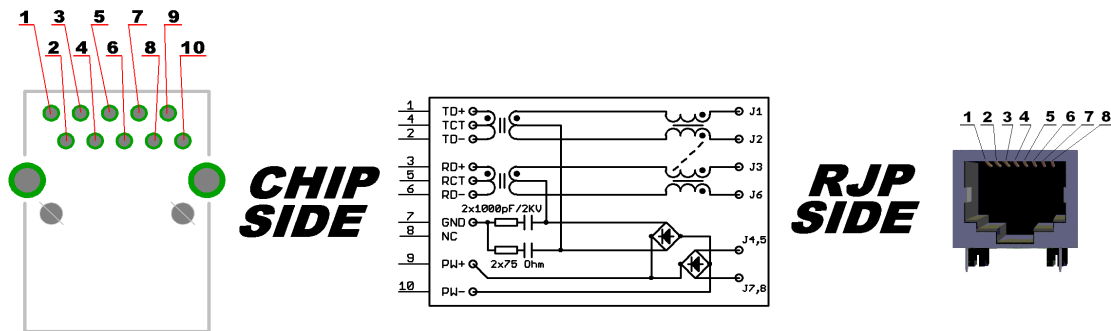

Pin #	Signal Name Chip Side	Pin #	Signal Name Chip Side
1	TPOUT+	6	TPIN-
2	TPOUT-	7	GND
3	TPIN+	8	Not Connected (NC)
4	3.3V	9	VIN
5	Not Connected (NC)	10	GND

- TPOUT-** Output Differential signal output.
- TPOUT+** Output Differential signal output.
- TPIN-** Input Differential signal input.
- TPIN+** Input Differential signal input.
- VIN** Input Power supply for the board – over Ethernet.

## **AVAILABLE DEMO SOFTWARE:**

You could find information about PIC-MICRO-WEB board, Microchip TCP/IP stack and how to change and configure the software on **Understanding PIC WEB boards** on [www.olimex.com/dev](http://www.olimex.com/dev).

## ORDER CODE:

**PIC-MICRO-WEB** – assembled and tested (no kit, no soldering required)

How to order?

You can order to us directly or by any of our distributors.

Check our web [www.olimex.com/dev](http://www.olimex.com/dev) for more info.



All boards produced by Olimex are RoHS compliant

### Revision history:

Board's Revision:

Rev. C - created October 2009

Manual's Revision:

Rev. D – edited April 2011

- edited, because of error in power supply voltage range. It was written from 10 – 50 V, but it is really from 24 – 50 V.

**Disclaimer:**

© 2011 Olimex Ltd. All rights reserved. Olimex®, logo and combinations thereof, are registered trademarks of Olimex Ltd. Other terms and product names may be trademarks of others.

The information in this document is provided in connection with Olimex products. No license, express or implied or otherwise, to any intellectual property right is granted by this document or in connection with the sale of Olimex products.

Neither the whole nor any part of the information contained in or the product described in this document may be adapted or reproduced in any material from except with the prior written permission of the copyright holder.

The product described in this document is subject to continuous development and improvements. All particulars of the product and its use contained in this document are given by OLIMEX in good faith. However all warranties implied or expressed including but not limited to implied warranties of merchantability or fitness for purpose are excluded.

This document is intended only to assist the reader in the use of the product. OLIMEX Ltd. shall not be liable for any loss or damage arising from the use of any information in this document or any error or omission in such information or any incorrect use of the product.