

PIC-MINI-WEB development board Users Manual

Rev. C, July 2006
Copyright(c) 2010, OLIMEX Ltd, All rights reserved

INTRODUCTION:

PIC-MINI-WEB is with dimensions only 55 x 36 mm but don't let this fool you. This board is very powerful and will allow you to connect almost everything to Internet.

The board has PIC18F25J10 microcontroller with 32KB of program Flash memory, 1024 RAM memory and allows Microchip free TCP-IP stack to be programmed. In addition on-board flash of 1 Mbit (128KB) is available as data storage for web pages and other data. The LAN connector could be connected to 10 Mbit Ethernet switch or hub.

There is also IDC14 connector with 10 GPIOs available for future extension and power supply and reset signals.

What CAN YOU do with this board? You name it: you can setup web server with dynamic web pages which allows you to read PIC resources or to drive them through web interface, i.e. to read ADC and display it on the web or to toggle GPIO outputs from the web, very convenient way to make home automation for instance and to monitor and control your home from anywhere with Internet. Another service this board can run is FTP server, either you can control the PIC by Telnet, or you can send and receive e-mails and trigger hardware events with them. All this is possible due to the free firmware which Microchip provides, and the best of all - it has neither upfront charges for software nor royalties.

BOARD FEATURES:

- PIC18F25J10 microcontroller, ENC28J60 Ethernet controller, 32KB Flash, 1KB RAM
- 1Mbit on board serial flash for web pages storage
- ICSP/ICD connector for programming and debugging with PIC-ICD2, PIC-ICD2-POCKET and PIC-ICD2-TINY.
- Reset button
- User event button connected to RB0 interrupt
- Complete web server and TCP-IP stack support as per Microchip's open source TCP-IP stack
- Power plug-in jack for +5VDC power supply
- Voltage regulator +3.3V and filtering capacitors
- Status LED
- Extension header to connect to other boards, 10 GPIOs and power supply, reset signals
- Dimensions 55x36 mm (2.16x1.42")

ELECTROSTATIC WARNING:

The PIC-MINI-WEB board is shipped in protective anti-static packaging. The board must not be subject to high electrostatic potentials. General practice for working with static sensitive devices should be applied when working with this board.

BOARD USE REQUIREMENTS:

Cables: Depends on the used programming/debugging tool. It could be 1.8 meter USB A-B cable to connect PIC-ICD2 or PIC-ICD2-POCKET to USB host on PC and RS232 cable, if you use PIC-ICD2-TINY. You will also need a LAN cable.

Hardware: Programmer/Debugger – some of Olimex programmers are applicable, for example **PIC-ICD2, PIC-ICD2-POCKET, PIC-ICD2-TINY** or other compatible programming/debugging tool.

!!!Warning!!! When you want to program this microcontroller with PIC-ICD2, PIC-ICD2-POCKET or PIC-ICD2-TINY, before connecting the programmer to your target board, you should first connect the programmer to your computer and open MPLAB. There, first from menu Configure – Select Device – choose the microcontroller you are about to program, then from menu Programmer – Select Programmer – choose MPLAB ICD 2, wait while MPLAB is downloading operation system, and after ICD2 is connected – check in menu Programmer – Settings – Power – there is option – Power target circuit from MPLAB ICD 2 – this option should be forbidden, you could not select it. Now it is safe to connect the programmer to your target board.

Software: PIC-MINI-WEB is tested with **MPLAB IDE v.7.62 + MPLAB C18** C compiler. It is possible that the stack might not function properly if used with later versions of MPLAB IDE.

PROCESSOR FEATURES:

PIC-MINI-WEB board uses MCU **PIC18F25J10** from Microchip with these features:

- Operating voltage range: 2.0V to 3.6V
- 5.5V tolerant input (digital pins only)
- On-chip 2.5V regulator
- Low-power, high-speed CMOS Flash technology
- C compiler optimized architecture:
 - o Optional extended instruction set designed to optimize re-entrant code
- Priority levels for interrupts
- 8 x 8 Single-Cycle Hardware Multiplier
- Extended Watchdog Timer (WDT)
 - o Programmable period from 4 ms to 131s
- Single-Supply In-Circuit Serial Programming™ (ICSP™) via two pins
- In-Circuit Debug (ICD) with three Break points via two pins
- Power-Managed modes:
 - o Run: CPU on, peripherals on
 - o Idle: CPU off, peripherals on
 - o Sleep: CPU off, peripherals off
- Two Crystal modes, up to 40 MHz
- Two External Clock modes, up to 40 MHz
- Internal 31 kHz oscillator

- Secondary oscillator using Timer1 @ 32 kHz
- Two-Speed Oscillator Start-up
- Fail-Safe Clock Monitor:
 - o Allows for safe shutdown if peripheral clock stops
- High-current sink/source 25 mA/25 mA (PORTB and PORTC)
- Three programmable external interrupts
- Four input change interrupts
- One Capture/Compare/PWM (CCP) module
- One Enhanced Capture/Compare/PWM (ECCP) module:
 - o One, two or four PWM outputs
 - o Selectable polarity
 - o Programmable dead time
 - o Auto-Shutdown and Auto-Restart
- Two Master Synchronous Serial Port (MSSP) modules supporting 3-wire SPI™ (all 4 modes) and I2C™ Master and Slave modes
- One Enhanced Addressable USART module:
 - o Supports RS-485, RS-232 and LIN 1.2
 - o Auto-Wake-up on Start bit
 - o Auto-Baud Detect
- 10-bit, up to 13-channel Analog-to-Digital Convertor module (A/D):
 - o Auto-acquisition capability
 - o Conversion available during Sleep
 - o Self-calibration feature
- Dual analog comparators with input multiplexing

BLOCK DIAGRAM:

FIGURE 1-1: PIC18F24J10/25J10 (28-PIN) BLOCK DIAGRAM

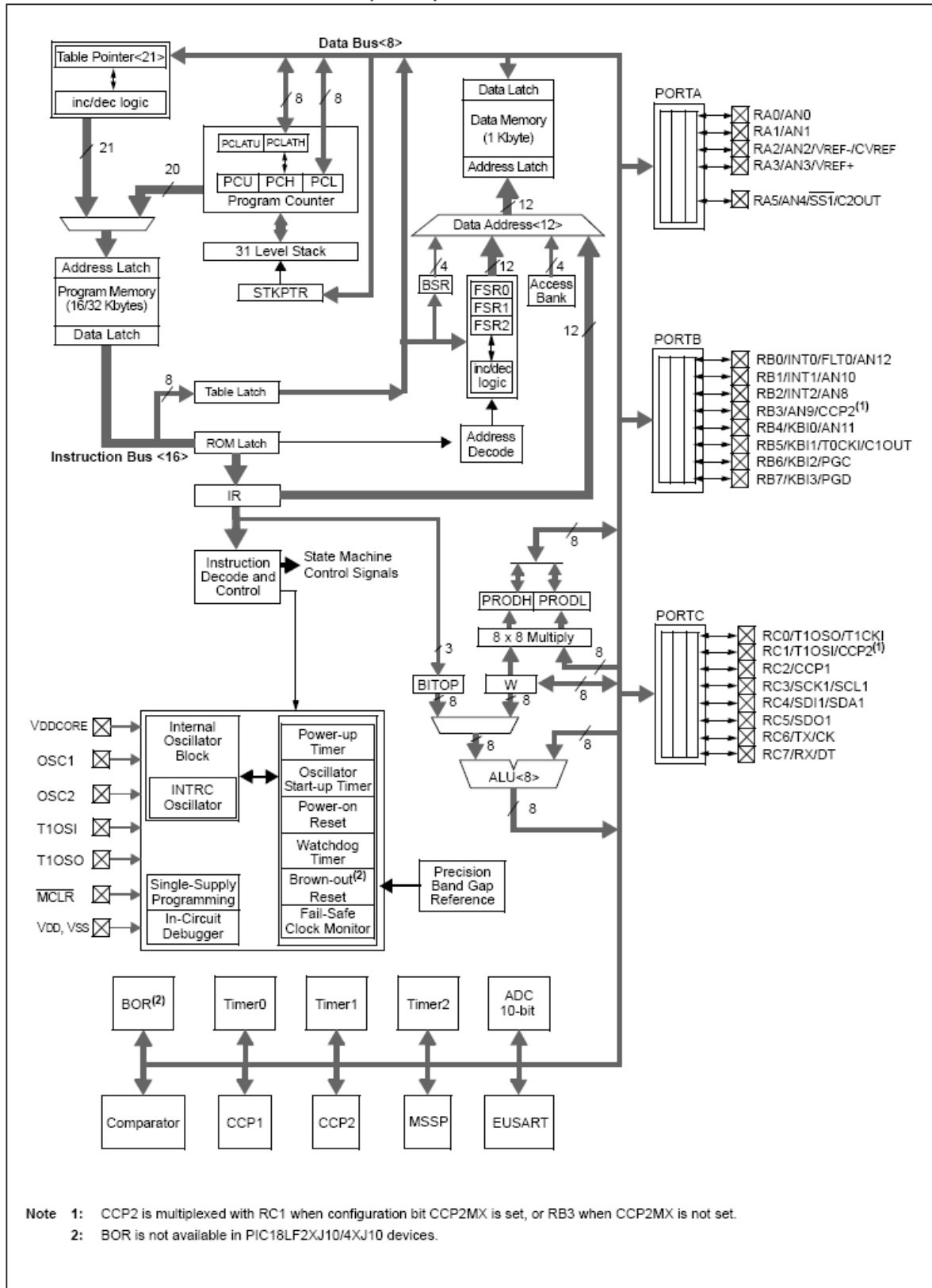

MEMORY MAP:

FIGURE 5-1: PROGRAM MEMORY MAP AND STACK FOR PIC18F45J10 FAMILY DEVICES

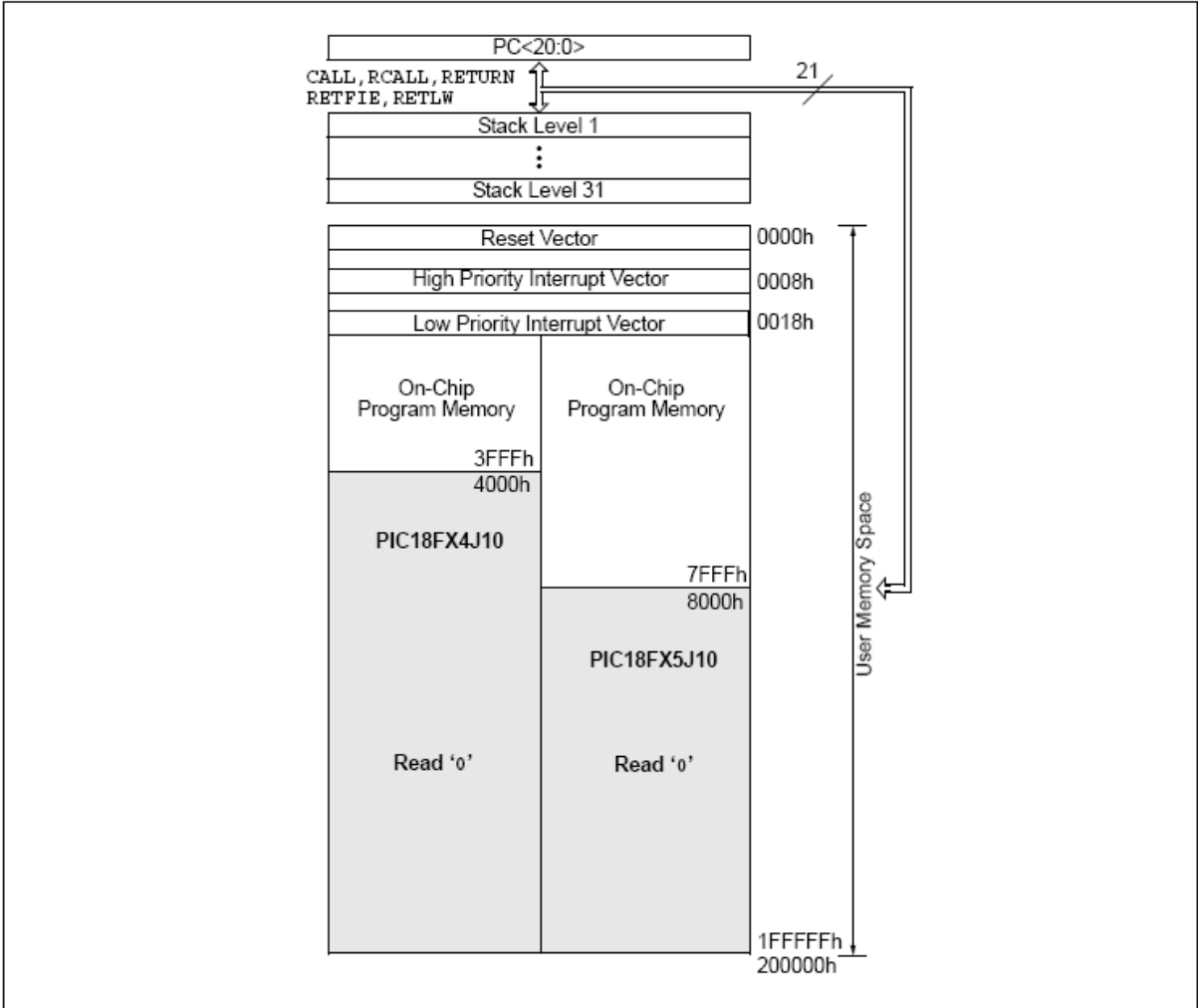

SCHEMATIC:

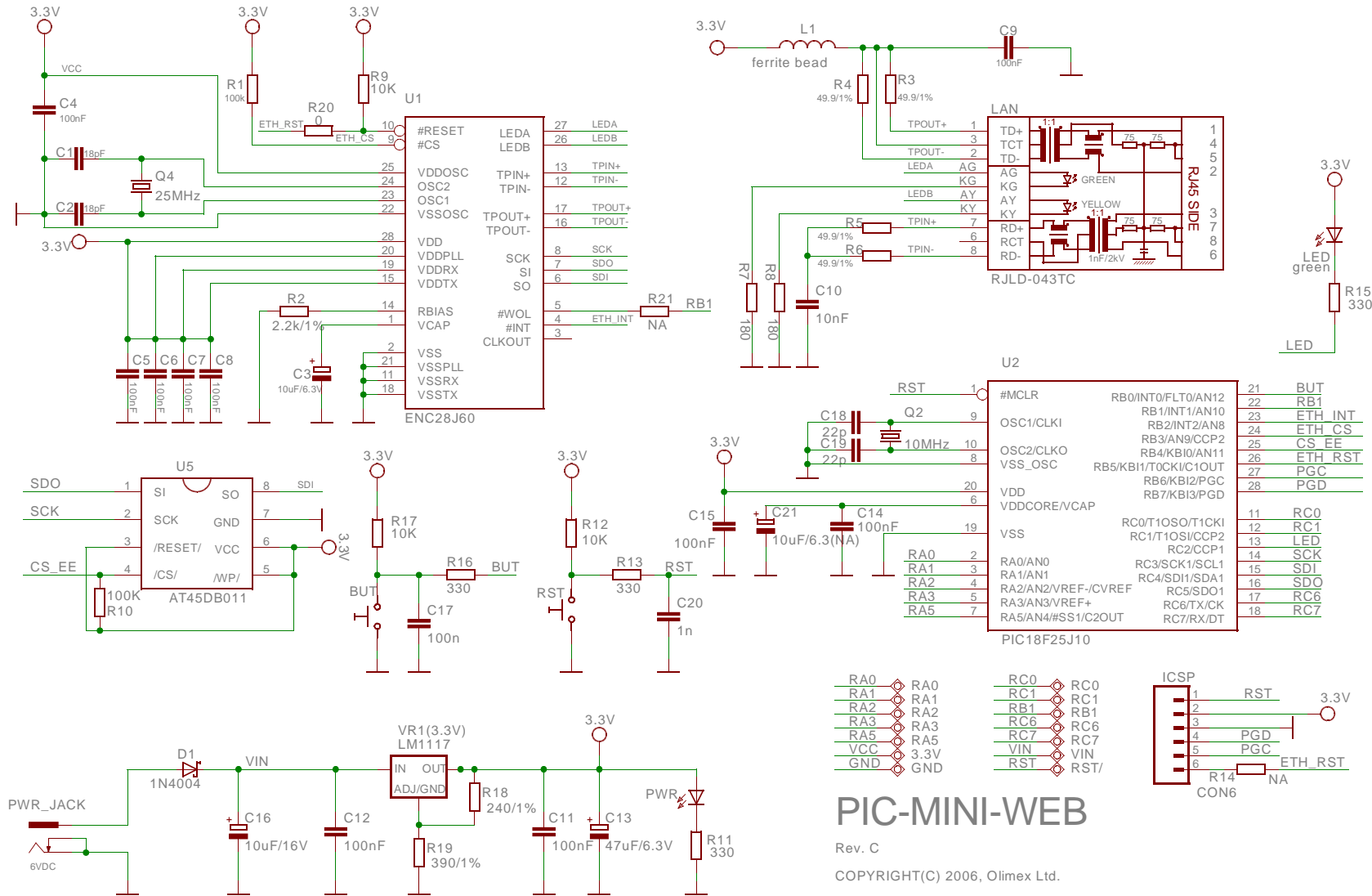

PIC-MINI-WEB

Rev. C
 COPYRIGHT(C) 2006, Olimex Ltd.
<http://www.olimex.com/dev>

BOARD LAYOUT:

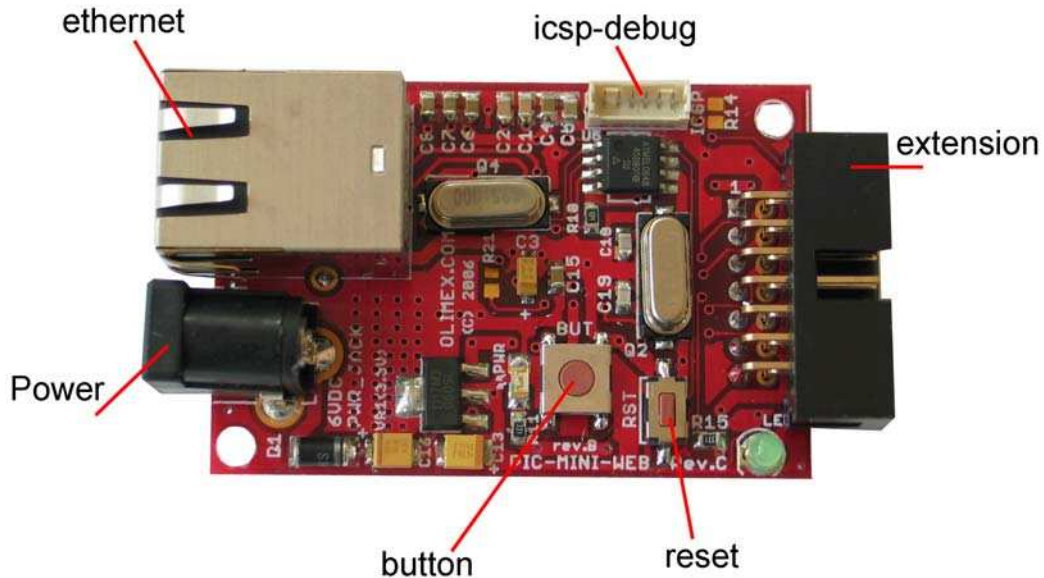

POWER SUPPLY CIRCUIT:

PIC-MINI-WEB takes power from PWR_JACK where 6-9 VDC is applied by external power source

The board power consumption is: about 180 mA with all peripherals and MCU running at full speed.

RESET CIRCUIT:

PIC-MINI-WEB reset circuit is made with R12 (10k) pull-up, R13 (330 Ω) and capacitor C20 (100nF) and RST button. Manual reset is possible by the RST button.

CLOCK CIRCUIT:

Quartz crystal 10 MHz is connected to **PIC18F25J10** pin 9 clock in (OSC1/CLKIN) and pin 10 clock out (OSC2/CLKOUT).

JUMPER DESCRIPTION:

There aren't any jumpers.

INPUT/OUTPUT:

One **User button** with name **BUTTON** – connected to PIC18F25J10 pin 21 (PORTB.RB0/INT0/FLT0/AN12);

Status green LED connected to PIC18F25J10 pin13 (PORTC.RC2/CCP1).

Power supply red LED with name **PWR** – indicates that external powers source is applied and board power supply is applied;

EXTERNAL CONNECTORS DESCRIPTION:

ICSP:

Pin #	Signal Name
1	RST
2	+5V
3	GND
4	PGD
5	PGC
6	PGM

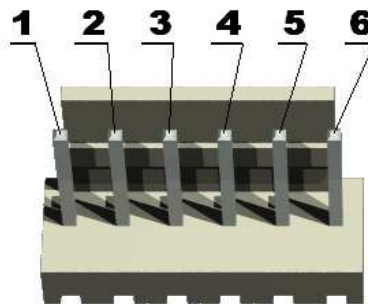

PGD I/O **Program Data.** Serial data for programming.

PGC Input **Program Clock.** Clock used for transferring the serial data (output from ICSP, input for the MCU).

PWR JACK:

Pin #	Signal Name
1	Power Input
2	GND

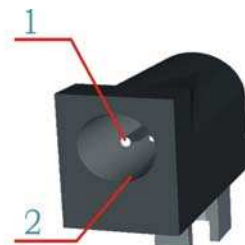

The power input should be +(6 - 9)VDC.

EXT:

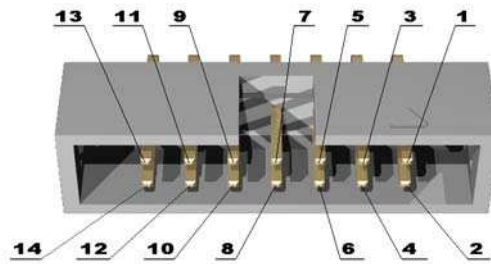

Pin #	Signal Name	Pin #	Signal Name
1	RA0/AN0	2	RC0/T1OSO/T1CKI
3	RA1/AN1	4	RC1/T1OSI/CCP2
5	RA2/AN2/VREF-/CVREF	6	RB1/INT1/AN10
7	RA3/AN3/VREF+	8	RC6/TX/CK
9	RA5/AN4/#SS1/C2OUT	10	RC7/RX/DT
11	VCC +3.3 V	12	VIN
13	GND	14	RST/

LAN:

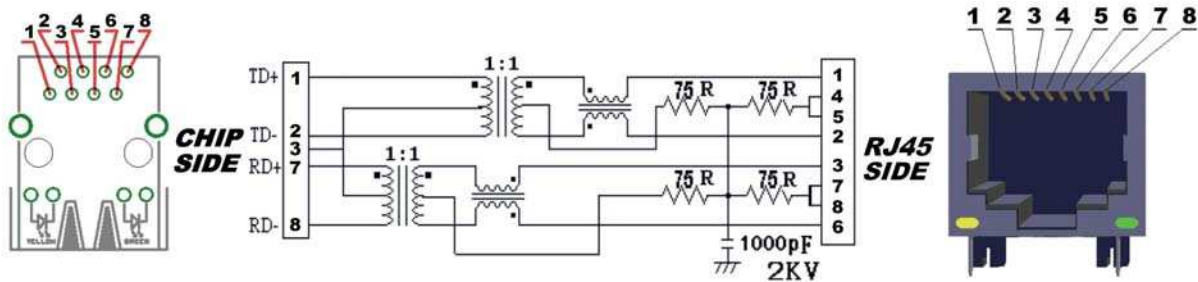

Pin #	Signal Name Chip Side	Pin #	Signal Name Chip Side
1	TPOUT+	5	Not Connected (NC)
2	TPOUT-	6	Not Connected (NC)
3	3.3V	7	TPIN+
4	Not Connected (NC)	8	TPIN-

LED	Color	Usage
Right	Yellow	Activity
Left	Green	100Mbits/s (Half/Full duplex)

TPOUT- Output Differential signal output.

TPOUT+ Output Differential signal output.

TPIN- Input Differential signal input.

TPIN+ Input Differential signal input.

MECHANICAL DIMENSIONS:

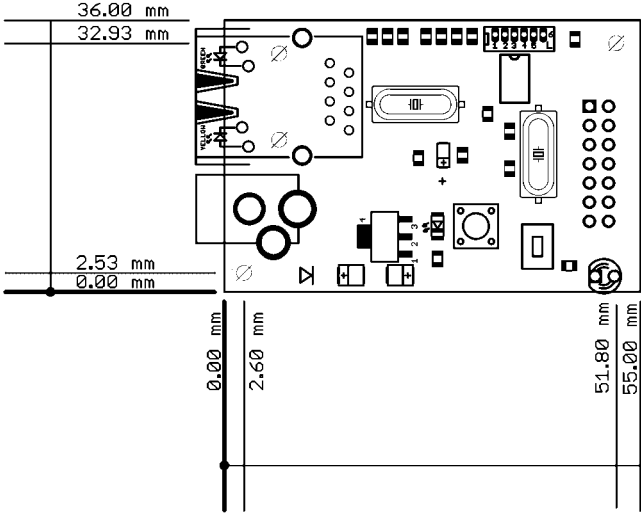

All measures are in mm.

AVAILABLE DEMO SOFTWARE:

You could find information about PIC-MINI-WEB board, Microchip TCP/IP stack and how to change and configure the software in **Understanding PIC-WEB boards** on www.olimex.com/dev.

ORDER CODE:

PIC-MINI-WEB – assembled and tested (no kit, no soldering required)

How to order?

You can order to us directly or by any of our distributors.

Check our web www.olimex.com/dev for more info.



All boards produced by Olimex are RoHS compliant

Revision history:

REV. C - created July 2006

Disclaimer:

© 2010 Olimex Ltd. All rights reserved. Olimex®, logo and combinations thereof, are registered trademarks of Olimex Ltd. Other terms and product names may be trademarks of others.

The information in this document is provided in connection with Olimex products. No license, express or implied or otherwise, to any intellectual property right is granted by this document or in connection with the sale of Olimex products.

Neither the whole nor any part of the information contained in or the product described in this document may be adapted or reproduced in any material form except with the prior written permission of the copyright holder.

The product described in this document is subject to continuous development and improvements. All particulars of the product and its use contained in this document are given by OLIMEX in good faith. However all warranties implied or expressed including but not limited to implied warranties of merchantability or fitness for purpose are excluded. This document is intended only to assist the reader in the use of the product. OLIMEX Ltd. shall not be liable for any loss or damage arising from the use of any information in this document or any error or omission in such information or any incorrect use of the product.