



Low Profile, Low Power ±1.7g Dual Axis Accelerometer with Ratiometric Outputs

MXR6500G/M

FEATURES

- Low power consumption: typically 2.0mA @ 3.0V
- RoHS compliant
- Resolution better than 1 mg
- Dual axis accelerometer fabricated on a monolithic CMOS IC
- On chip mixed signal processing
- No moving parts; No loose particle issues
- >50,000 g shock survival rating
- Low profile LCC package: 5mm X 5mm X 1.55mm
- 2.7V to 3.6V single supply continuous operation
- No adjustment needed outside

APPLICATIONS

- Automotive** – Vehicle Security/Active Suspension/ABS
Headlight Angle Control/Tilt Sensing
- Security** – Gas Line/Elevator/Fatigue Sensing
- Office Equipment** – Computer Peripherals/PDA's/Cell Phones
- Gaming** – Joystick/RF Interface/Menu Selection/Tilt Sensing
- White Goods** – Spin/Vibration Control

GENERAL DESCRIPTION

The MXR6500G/M is an low noise and low profile, dual axis accelerometer fabricated on a standard, submicron CMOS process. It is a complete sensing system with on-chip mixed mode signal processing. The MXR6500G/M measures acceleration with a full-scale range of ±1.7 g and a sensitivity of 500mV/g @3V at 25°C. It can measure both dynamic acceleration (e.g., vibration) and static acceleration (e.g., gravity). The MXR6500G/M design is based on heat convection and requires no solid proof mass. This eliminates stiction and particle problems associated with competitive devices and provides shock survival up to 50,000 g, leading to significantly lower failure rates and lower loss due to handling during assembly.

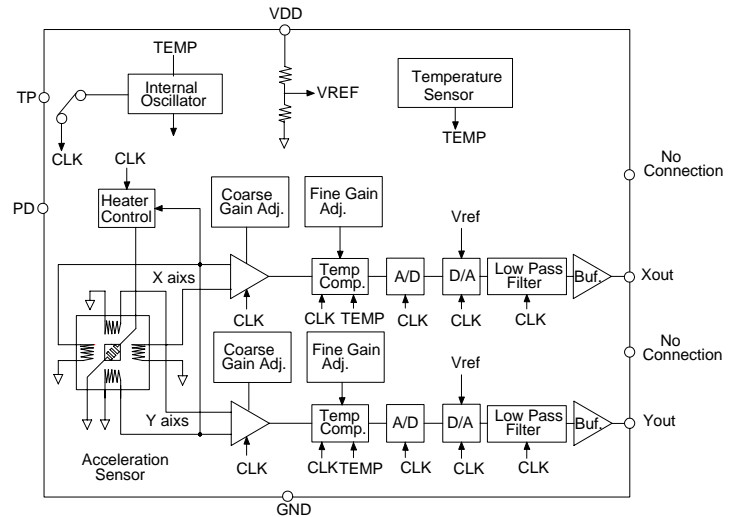

MXR6500G/M FUNCTIONAL BLOCK DIAGRAM

The MXR6500G/M provides two ratiometric analog outputs.

The maximum noise floor is $1 \text{ mg}/\sqrt{\text{Hz}}$ allowing signals below 1mg to be resolved at 1 Hz bandwidth. The MXR6500G/M is available in a hermetically sealed low profile LCC surface mount package (5mm x 5mm x 1.55mm). It is operational over a -40°C to 85°C (M) and 0°C to 70°C (G) temperature range.

Information furnished by MEMSIC is believed to be accurate and reliable. However, no responsibility is assumed by MEMSIC for its use, nor for any infringements of patents or other rights of third parties which may result from its use. No license is granted by implication or otherwise under any patent or patent rights of MEMSIC.

©MEMSIC, Inc.
800 Turn pike Street, Suite 202, North Andover, MA01845, USA
Tel: +1 978 738 0900 Fax: +1 978 738 0196
www.memsic.com

MXR6500G/M SPECIFICATIONS (Measurements @ 25°C, Acceleration = 0 g unless otherwise noted; V_{DD} = 3.0V unless otherwise specified)

Parameter	Conditions	MXR6500G			MXR6500M			Units
		Min	Typ	Max	Min	Typ	Max	
SENSOR INPUT	Each Axis							
Measurement Range ¹		±1.7			±1.7			g
Nonlinearity	Best fit straight line		0.5	1.0		0.5	1.0	% of FS
Alignment Error ²			±1.0			±1.0		degrees
Transverse Sensitivity ³			±2.0			±2.0		%
SENSITIVITY	Each Axis							
Sensitivity, Analog Outputs at output pins		475	500	525	475	500	525	mV/g
Change over Temperature (compensated)	Δ from 25°C			15			20	%
ZERO g BIAS LEVEL	Each Axis							
0 g Offset		-0.1	0.00	+0.1	-0.1	0.00	+0.1	g
0 g Voltage		1.45	1.50	1.55	1.45	1.50	1.55	V
0 g Offset over Temperature	Δ from 25°C		1.5			1.5		mg/°C
	Δ from 25°C		0.75			0.75		mV/°C
NOISE PERFORMANCE								
Noise Density, rms			0.4	1.0		0.4	1.0	mg/√Hz
FREQUENCY RESPONSE								
3dB Bandwidth		15	17	19	15	17	19	Hz
SELF TEST								
Continuous Voltage at outputs under failure	@3V Supply, output rails to supply voltage		3.0			3.0		V
OUTPUTS PERFORMANCE								
Normal Output Range	Output High	2.8			2.8			V
	Output Low			0.2			0.2	V
Current	Source or sink, @ 2.7V-3.6V supply			100			100	μA
Turn-On Time ⁴	@3V Supply		75			75		mS
POWER SUPPLY								
Operating Voltage Range		2.7	3.0	3.6	2.7	3.0	3.6	V
Supply Current	@ 3V		2.0			2.0		mA
TEMPERATURE RANGE								
Operating Range		0		+70	-40		+85	°C

NOTES

¹ Guaranteed by measurement of initial offset and sensitivity.

² Alignment error is specified as the angle between the true and indicated axis of sensitivity.

³ Transverse sensitivity is the algebraic sum of the alignment and the inherent sensitivity errors.

⁴ Output settled to within ±17mg.

ABSOLUTE MAXIMUM RATINGS*

Supply Voltage (V_{DD})-0.5 to +7.0V
 Storage Temperature-65°C to +150°C
 Acceleration50,000 g

*Stresses above those listed under Absolute Maximum Ratings may cause permanent damage to the device. This is a stress rating only; the functional operation of the device at these or any other conditions above those indicated in the operational sections of this specification is not implied. Exposure to absolute maximum rating conditions for extended periods may affect device reliability.

Pin Description: LCC-8 Package

Pin	Name	Description	I/O
1	PD	Power Down Control	I
2	TP	Connect to ground	I
3	COM	Common	I
4	NC	Do Not Connect	NC
5	NC	Do Not Connect	NC
6	Yout	Y Channel Output	O
7	Xout	X Channel Output	O
8	V _{DD}	2.7V to 3.6V	I

Ordering Guide

Model	Package Type	Temperature Range
MXR6500GP	LCC8 RoHS compliant	0 to +70°C
MXR6500MP	LCC8 RoHS compliant	-40 to +85°C
MXR6500GB	LCC8, Pb-free RoHS compliant	0 to +70°C
MXR6500MB	LCC8, Pb-free RoHS compliant	-40 to +85°C

All parts are shipped in tape and reel packaging.

Caution: ESD (electrostatic discharge) sensitive device.

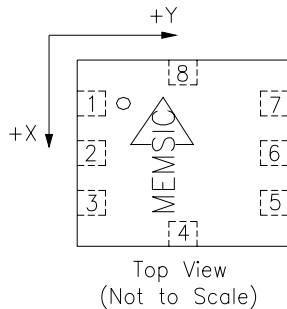

Note: The MEMSIC logo's arrow indicates the -X sensing direction of the device. The +Y sensing direction is rotated 90° away from the +X direction following the right-hand rule. Small circle indicates pin one (1).



THEORY OF OPERATION

The MEMSIC device is a complete dual-axis acceleration measurement system fabricated on a monolithic CMOS IC process. The device operation is based on heat transfer by natural convection and operates like other accelerometers having a proof mass except it is a gas in the MEMSIC sensor.

A single heat source, centered in the silicon chip is suspended across a cavity. Equally spaced aluminum/polysilicon thermopiles (groups of thermocouples) are located equidistantly on all four sides of the heat source (dual axis). Under zero acceleration, a temperature gradient is symmetrical about the heat source, so that the temperature is the same at all four thermopiles, causing them to output the same voltage.

Acceleration in any direction will disturb the temperature profile, due to free convection heat transfer, causing it to be asymmetrical. The temperature, and hence voltage output of the four thermopiles will then be different. The differential voltage at the thermopile outputs is directly proportional to the acceleration. There are two identical acceleration signal paths on the accelerometer, one to measure acceleration in the x-axis and one to measure acceleration in the y-axis. Please visit the MEMSIC website at www.memsic.com for a picture/graphic description of the free convection heat transfer principle.

PIN DESCRIPTIONS

V_{DD} – This is the supply input for the circuits and the sensor heater in the accelerometer. The DC voltage should be between 2.7 and 3.6 volts. Refer to the section on PCB layout and fabrication suggestions for guidance on external parts and connections recommended.

COM– This is the ground pin for the accelerometer.

TP– This pin should be connected to ground.

Xout – This pin is the output of the X-axis acceleration sensor. The user should ensure the load impedance is sufficiently high as to not source/sink >100µA typical. While the sensitivity of this axis has been programmed at the factory to be the same as the sensitivity for the y-axis, the accelerometer can be programmed for non-equal sensitivities on the x- and y-axes. Contact the factory for additional information.

Yout – This pin is the output of the Y-axis acceleration sensor. The user should ensure the load impedance is sufficiently high as to not source/sink >100µA typical. While the sensitivity of this axis has been programmed at the factory to be the same as the sensitivity for the x-axis, the accelerometer can be programmed for non-equal sensitivities on the x- and y-axes. Contact the factory for additional information.

PD– Pin 1 is the power down control pin. Pull this pin HIGH will put the accelerometer into power down mode. When the part goes into power down mode, the total current will be smaller than 0.1uA at 3V.

In normal operation mode, this pin should be connected to Ground.

DISCUSSION OF TILT APPLICATIONS AND RESOLUTION

Tilt Applications: One of the most popular applications of the MEMSIC accelerometer product line is in tilt/inclination measurement. An accelerometer uses the force of gravity as an input to determine the inclination angle of an object.

A MEMSIC accelerometer is most sensitive to changes in position, or tilt, when the accelerometer’s sensitive axis is perpendicular to the force of gravity, or parallel to the Earth’s surface. Similarly, when the accelerometer’s axis is parallel to the force of gravity (perpendicular to the Earth’s surface), it is least sensitive to changes in tilt.

Following table and figure help illustrate the output changes in the X- and Y-axes as the unit is tilted from +90° to 0°. Notice that when one axis has a small change in output per degree of tilt (in mg), the second axis has a large change in output per degree of tilt. The complementary nature of these two signals permits low cost accurate tilt sensing to be achieved with the MEMSIC device (reference application note AN-00MX-007).

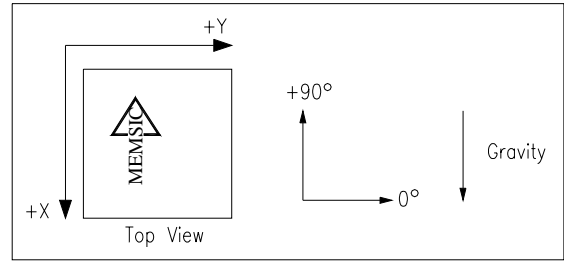

Accelerometer Position Relative to Gravity

X-Axis Orientation To Earth's Surface (deg.)	X-Axis		Y-Axis	
	X Output (g)	Change per deg. of tilt (mg)	Y Output (g)	Change per deg. of tilt (mg)
90	1.000	0.15	0.000	17.45
85	0.996	1.37	0.087	17.37
80	0.985	2.88	0.174	17.16
70	0.940	5.86	0.342	16.35
60	0.866	8.59	0.500	15.04
45	0.707	12.23	0.707	12.23
30	0.500	15.04	0.866	8.59
20	0.342	16.35	0.940	5.86
10	0.174	17.16	0.985	2.88
5	0.087	17.37	0.996	1.37
0	0.000	17.45	1.000	0.15

Changes in Tilt for X- and Y-Axes

Resolution: The accelerometer resolution is limited by noise. The output noise will vary with the measurement bandwidth. With the reduction of the bandwidth, by applying an external low pass filter, the output noise drops. Reduction of bandwidth will improve the signal to noise ratio and the resolution. The output noise scales directly with the square root of the measurement bandwidth. The maximum amplitude of the noise, its peak- to- peak value, approximately defines the worst case resolution of the measurement. With a simple RC low pass filter, the rms noise is calculated as follows:

$$\text{Noise (mg rms)} = \text{Noise(mg/}\sqrt{\text{Hz}}) * \sqrt{(\text{Bandwidth(Hz)} * 1.6)}$$

The peak-to-peak noise is approximately equal to 6.6 times the rms value (for an average uncertainty of 0.1%).

POWER SUPPLY NOISE REJECTION

One capacitor is recommended for best rejection of power supply noise (reference figure below). The capacitor should be located as close as possible to the device supply pin (V_{DD}). The capacitor lead length should be as short as possible, and surface mount capacitor is preferred. For typical applications, the capacitor can be ceramic 0.1 µF.

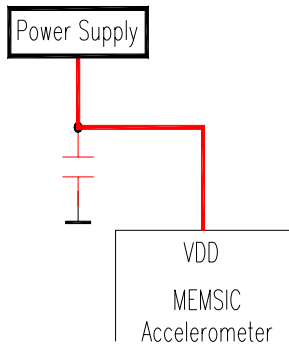

Power supply noise rejection

PCB LAYOUT AND FABRICATION SUGGESTIONS

1. It is best to connect a 0.1 μ F capacitor directly across V_{DD} and COM pin.
2. Robust low inductance ground wiring should be used.
3. Care should be taken to ensure there is “thermal symmetry” on the PCB immediately surrounding the MEMSIC device and that there is no significant heat source nearby.
4. A metal ground plane should be added directly beneath the MEMSIC device. The size of the plane should be similar to the MEMSIC device’s footprint and be as thick as possible.
5. Vias can be added symmetrically around the ground plane. Vias increase thermal isolation of the device from the rest of the PCB.

LCC-8 LOW PROFILE PACKAGE DRAWING

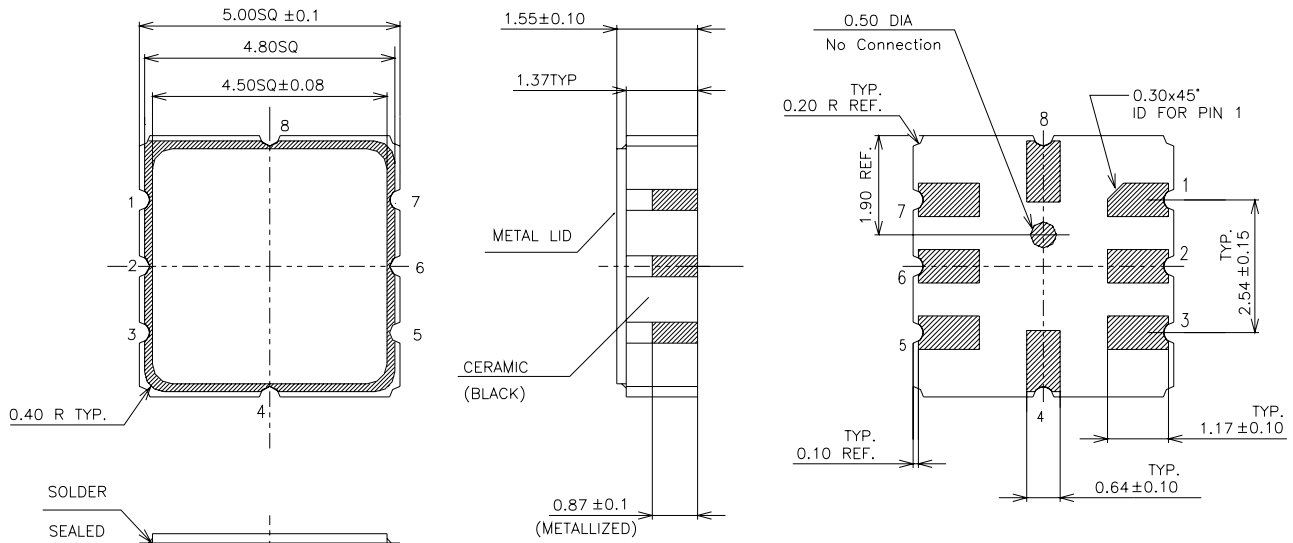

- NOTES :
1. UNIT:mm
 2. LID GROUNDED
 3. TOLERANCE UNLESS OTHERWISE SPECIFIED WITHIN ± 0.20

Hermetically Sealed Package Outline