

LOTUS

HIGH-PERFORMANCE WIRELESS SENSOR NETWORK PLATFORM

- Cortex® M3 32-bit Processor at 10 – 100MHz
- 64kB SRAM, 512kB FLASH, 64MB Serial FLASH
- Integrated 802.15.4 Radio with On-board Antenna
- 250 kbps, High Data Rate Radio
- Multi-color Status Indicator LED
- USB Client With On-board mini-B Connector
- Rich Set of Standard I/O: 3xUART, SPI, I2C, I2S, GPIO, ADC
- Expansion Connector for Light, Temperature, RH, Barometric Pressure, Acceleration/Seismic, Acoustic, Magnetic and other MEMSIC Sensor Boards

Applications

- Acoustic, Video, Vibration and Other High Speed Sensor Data
- Condition Based Maintenance
- Industrial Monitoring and Analysis
- Seismic and Vibration Monitoring

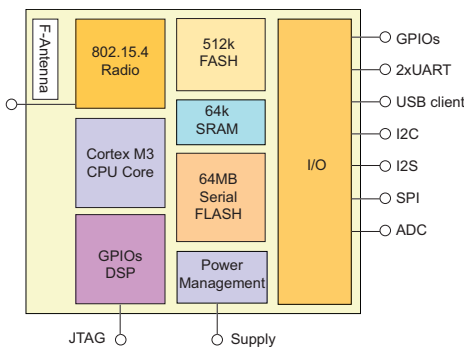

Lotus Block Diagram



LOTUS

The Lotus is an advanced wireless sensor node platform. It is built around the low-power Cortex M3 CPU and also integrates an 802.15.4 compliant radio. The design is modular and stackable with interface connectors for expansion boards. The Lotus platform features several new capabilities that enhance the overall functionality of MEMSIC's wireless sensor networking products.

Processor & Radio Platform

The Lotus is based on the NXP LPC1758. The LPC17xx is 32-bit ARM Cortex-M3 based microcontroller for embedded applications featuring a high level of integration and low power consumption. A single processor board can be configured to run your sensor application/processing and the network/radio communications stack simultaneously. The Lotus 51-pin expansion connector supports Analog Inputs, Digital I/O, I2C, SPI and UART interfaces. These interfaces make it easy to connect to a wide variety of external peripherals.

The Lotus uses the RF231 IEEE 802.15.4 radio transceiver from Atmel. The RF231 supports a 250kb/s data rate with 16 channels in the 2.4GHz band. The Lotus platform integrates a 2.4GHz on-board antenna which provides a nominal range of about 100 meters. For longer range, an optional SMA connector can be soldered directly to the board to connect to an external antenna along with power amplifier.

Sensor Boards

MEMSIC offers a variety of sensor and data acquisition boards for the Lotus Mote. All of these boards connect to the Lotus Mote via the standard 51-pin expansion connector. Custom sensor and data acquisition boards are also available. Please contact MEMSIC for additional information.

Processor/Radio Board	LPR2400	Remarks
Processor Performance		
Program Flash Memory	512K bytes	
Measurement (Serial) Flash	64M bytes	
RAM	64K bytes	
Serial Communications	USB	
Analog to Digital Converter	12 bit ADC	8 channel, 0-3V input
Other Interfaces	Digital I/O,I2C,SPI, UART	
Current Draw	50 mA	Active mode at 100MHz
	10 μ A	Sleep mode (total)
RF Transceiver		
Frequency band ¹	2405 MHz to 2480 MHz	ISM band, programmable in 1 MHz steps
Transmit (TX) data rate	250 kbps	
RF power	3 dBm (typ)	
Receive Sensitivity	-101 dBm (typ)	
Outdoor Range	> 500 m	1/2 wave dipole antenna, LOS
	> 50 m	on-board antenna, LOS
Current Draw	16 mA	Receive mode
	10 mA	TX, -17 dBm
	13 mA	TX, -3 dBm
	17 mA	TX, 3 dBm
Electromechanical		
Battery	2X AA batteries	Attached pack
External Power	2.7 V - 3.3 V	
User Interface	Tri color LED	Red, green and yellow
Size (in)	2.25 x 1.25 x 0.25	Excluding battery pack
(mm)	76 x 34 x 7	Excluding battery pack
Weight (oz)	0.7	Excluding batteries
(grams)	18	Excluding batteries
Expansion Connector	51-pin	All major I/O signals

Notes

¹5 MHz steps for compliance with IEEE 802.15.4/D18-2003.

Specifications subject to change without notice

Third Party Software

The Lotus is factory configured to run the RTOS. Several other operating systems are available for Lotus including Mot-eRunner and TinyOS. Additional system software is available from Open Source. For the latest operating systems and additional third party accessories please visit www.memsic.com



Lotus Mote (bottom view)

Ordering Information

Model	Description
LPR2400	Lotus Processor Radio Board