

# 300mA Regulator IC Monolithic IC MM3464 series

## Outline

This IC is a high speed response 300mA regulator IC with low quiescent current and high ripple rejection. No load input current is 20µA typ. And ripple rejection is 75dB typ. Dropout voltage is low at 160mV typ., and the output current is 300mA. Therefore the IC applies to most mobile equipment.

## Features

1. Output current	300mA
2. No load input current	20µA typ.
3. Input current(OFF)	0.1µA max.
4. Output voltage range	1.0~5.0V
5. Output voltage accuracy	±1%(±20mV,Vo<2V)
6. Dropout voltage	160mV typ. (Io=200mA)
7. Line regulation	0.2%/V max.
8. Load regulation	80mV max. (Io=0.1~200mA)
9. Ripple rejection	75dB typ. (f=1kHz)
10. Output Capacitor	1µF

## Package

SOT-25  
SOT89-5  
SC-82  
PLP-4A

## Applications

1. Cellular phones
2. Digital still cameras
3. Mobile equipments

## Block Diagram

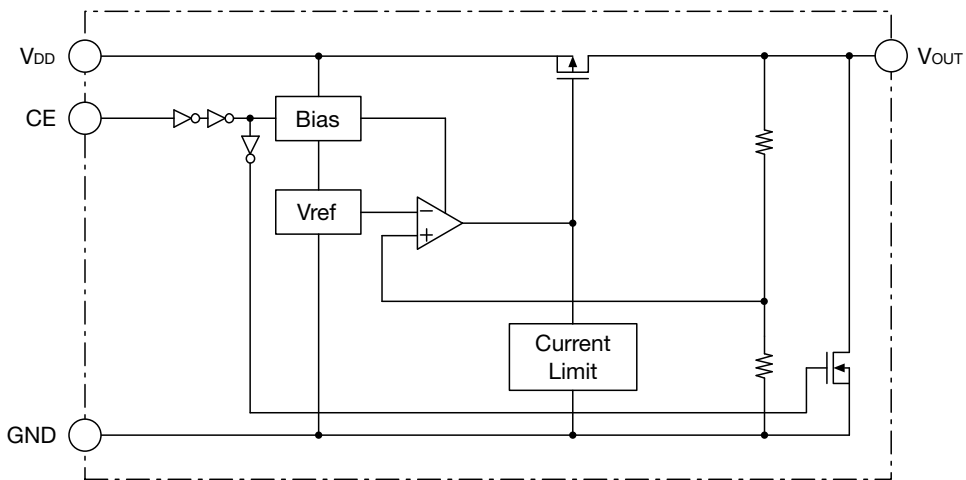

## Pin Assignment

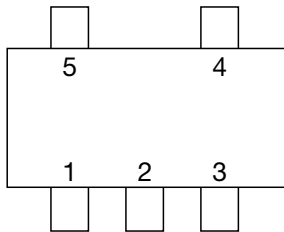

SOT-25  
(TOP VIEW)

1	V <sub>DD</sub>
2	GND
3	CE
4	NC
5	V <sub>OUT</sub>

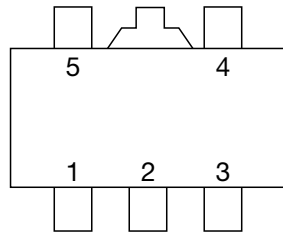

SOT89-5  
(TOP VIEW)

1	V <sub>OUT</sub>
2	GND
3	NC
4	CE
5	V <sub>DD</sub>

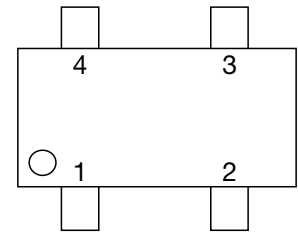

SC-82  
(TOP VIEW)

1	CE
2	GND
3	V <sub>OUT</sub>
4	V <sub>DD</sub>

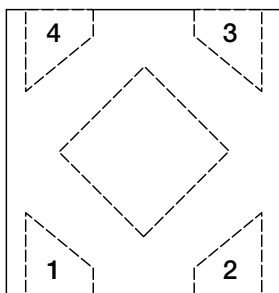

PLP-4A  
(TOP VIEW)

1	V <sub>OUT</sub>
2	GND
3	CE
4	V <sub>DD</sub>

## Pin Description

### SOT-25A

Pin No.	Pin name	Functions						
1	V <sub>DD</sub>	Voltage-supply pin						
2	GND	Ground pin						
3	CE	ON/OFF-Control pin						
		<table border="1"> <thead> <tr> <th>CE</th> <th>OUTPUT</th> </tr> </thead> <tbody> <tr> <td>Low</td> <td>OFF</td> </tr> <tr> <td>High</td> <td>ON</td> </tr> </tbody> </table>	CE	OUTPUT	Low	OFF	High	ON
		CE	OUTPUT					
		Low	OFF					
High	ON							
Connect CE pin with V <sub>DD</sub> pin, when it is not used.								
4	NC	No connection						
5	V <sub>OUT</sub>	Output pin						

### SOT89-5

Pin No.	Pin name	Functions						
1	V <sub>OUT</sub>	Output pin						
2	GND	Ground pin						
3	NC	No connection						
4	CE	ON/OFF-Control pin						
		<table border="1"> <thead> <tr> <th>CE</th> <th>OUTPUT</th> </tr> </thead> <tbody> <tr> <td>Low</td> <td>OFF</td> </tr> <tr> <td>High</td> <td>ON</td> </tr> </tbody> </table>	CE	OUTPUT	Low	OFF	High	ON
		CE	OUTPUT					
		Low	OFF					
High	ON							
Connect CE pin with V <sub>DD</sub> pin, when it is not used.								
5	V <sub>DD</sub>	Voltage-supply pin						

### SC-82

Pin No.	Pin name	Functions						
1	CE	ON/OFF-Control pin						
		<table border="1"> <thead> <tr> <th>CE</th> <th>OUTPUT</th> </tr> </thead> <tbody> <tr> <td>Low</td> <td>OFF</td> </tr> <tr> <td>High</td> <td>ON</td> </tr> </tbody> </table>	CE	OUTPUT	Low	OFF	High	ON
		CE	OUTPUT					
		Low	OFF					
High	ON							
Connect CE pin with V <sub>DD</sub> pin, when it is not used.								
2	GND	Ground pin						
3	V <sub>OUT</sub>	Output pin						
4	V <sub>DD</sub>	Voltage-supply pin						

### PLP-4A

Pin No.	Pin name	Functions						
1	V <sub>OUT</sub>	Output pin						
2	GND	Ground pin						
3	CE	ON/OFF-Control pin						
		<table border="1"> <thead> <tr> <th>CE</th> <th>OUTPUT</th> </tr> </thead> <tbody> <tr> <td>Low</td> <td>OFF</td> </tr> <tr> <td>High</td> <td>ON</td> </tr> </tbody> </table>	CE	OUTPUT	Low	OFF	High	ON
		CE	OUTPUT					
		Low	OFF					
High	ON							
Connect CE pin with V <sub>DD</sub> pin, when it is not used.								
4	V <sub>DD</sub>	Voltage-supply pin						

## Absolute Maximum Ratings (Except where noted otherwise Ta=25°C)

Item	Symbol	Ratings	Units
Storage temperature	T <sub>STG</sub>	-55~+150	°C
Supply voltage	V <sub>DD</sub>	-0.3~+7.0	V
CE input voltage	V <sub>CE</sub>	-0.3~V <sub>DD</sub> +0.3	V
Output voltage	V <sub>OUT</sub>	-0.3~V <sub>DD</sub> +0.3	V
Output current	I <sub>o max</sub>	500	mA
Power dissipation	Pd	350(Note1) (SOT-25)	mW
		1000(Note2) (SOT89-5)	
		330(Note3) (SC-82)	

Note1 : With PC board of glass epoxy 60 × 40 × 1.6<sup>t</sup>mm

Note2 : With PC board of glass epoxy 114.3 × 76.2 × 1.6<sup>t</sup>mm

Note3 : With PC board of glass epoxy 110 × 40 × 0.8<sup>t</sup>mm

## Recommended Operating Conditions (Except where noted otherwise Ta=25°C)

Item	Symbol	Ratings	Units
Operating ambient temperature	T <sub>JOP</sub>	-40~+85	°C
Operating voltage	V <sub>OP</sub>	2.0~6.5	V
Output current	I <sub>o</sub>	0~300	mA

**Electrical Characteristics 1** (Except where noted otherwise  $V_{DD}=V_{OUT}(typ.)+1V$ ,  $V_{CE}=V_{DD}$ ,  $T_a=25^{\circ}C$ )

Item	Symbol	Measurement conditions	Min.	Typ.	Max.	Units
Input current(OFF)	$I_{DDoff}$	$V_{CE}=0V$		0.01	0.1	$\mu A$
No-load input current	$I_{DD}$	$I_{OUT}=0mA$		20	50	$\mu A$
Output voltage	$V_{OUT}$	$I_{OUT}=10mA$ ( $V_{OUT} \geq 2.0V$ )	$\times 0.99$		$\times 1.01$	V
		$I_{OUT}=10mA$ ( $V_{OUT} \leq 1.95V$ )	-0.02		0.02	v
Line regulation	$V_{LINE}$	$V_O(yp.)+0.5V \leq V_{DD} \leq 6.5V$ $V_{OUT} \geq 1.1V, I_{OUT}=10mA$		0.01	0.2	% / V
		$1.6V \leq V_{DD} \leq 6.5V$ $V_{OUT} \leq 1.05V, I_{OUT}=10mA$				
Load regulation	$V_{LOAD}$	$0.1mA \leq I_{OUT} \leq 200mA$		20	80	mV
Dropout voltage	$V_{io}$	Please refer to another page				V
Ripple rejection (Note4)	RR	$f=1kHz, V_{ripple}=0.5V, I_{OUT}=30mA$ $V_{OUT} \geq 1.0V$		75		dB
$V_{out}$ temperature coefficient (Note4)	$\Delta V_{OUT} / \Delta T$	$I_{OUT}=30mA$ $-40^{\circ}C \leq T_{OP} \leq 85^{\circ}C$		$\pm 50$		ppm / $^{\circ}C$
Output current limit	$I_{lim}$		300	400		mA
Output short-circuit current	$I_{short}$	$V_{OUT}=0V$		30		mA
CE H threshold voltage	$V_{CEH}$		1.2		6.0	V
CE L threshold voltage	$V_{CEL}$				0.3	V
CE H threshold voltage	$I_{CEH}$		-0.1		0.1	$\mu A$
CE L threshold voltage	$I_{CEL}$		-0.1		0.1	$\mu A$
CL Discharge resistance	$R_{disc}$			780		$\Omega$

Note4 : The parameter is guaranteed by design.

**Electrical Characteristics 2** (Except where noted otherwise  $V_{DD}=V_{OUT}(typ.)+1V$ ,  $V_{CE}=V_{DD}$ ,  $T_a=25^{\circ}C$ )

Model No.	Item							
	Output voltage				Dropout voltage			
	$V_{OUT}$ (V)				$V_{io}$ (mV)			
	Measurement conditions	Min.	Typ.	Max.	Measurement conditions	Min.	Typ.	Max.
MM3464A10	$I_{OUT}=10mA$	0.980	1.000	1.020	$I_{OUT}=200mA$ $V_{OUT}<1.5V$ (Note5)		660	1300
MM3464Z10		1.030	1.050	1.070				
MM3464A11		1.080	1.100	1.120				
MM3464Z11		1.130	1.150	1.170				
MM3464A12		1.180	1.200	1.220				
MM3464Z12		1.230	1.250	1.270				
MM3464A13		1.280	1.300	1.320				
MM3464Z13		1.330	1.350	1.370				
MM3464A14		1.380	1.400	1.420				
MM3464Z14		1.430	1.450	1.470				
MM3464A15		1.480	1.500	1.520				
MM3464Z15		1.530	1.550	1.570				
MM3464A16		1.580	1.600	1.620				
MM3464Z16		1.630	1.650	1.670				
MM3464A17		1.680	1.700	1.720				
MM3464Z17		1.730	1.750	1.770				
MM3464A18		1.780	1.800	1.820				
MM3464Z18		1.830	1.850	1.870				
MM3464A19		1.880	1.900	1.920				
MM3464Z19		1.930	1.950	1.970				
MM3464A20		1.980	2.000	2.020				
MM3464Z20		2.030	2.050	2.071				
MM3464A21		2.079	2.100	2.121				
MM3464Z21		2.129	2.150	2.172				
MM3464A22		2.178	2.200	2.222				
MM3464Z22		2.228	2.250	2.273				
MM3464A23		2.277	2.300	2.323				
MM3464Z23		2.327	2.350	2.374				
MM3464A24		2.376	2.400	2.424				
MM3464Z24	2.426	2.450	2.475					
MM3464A25	2.475	2.500	2.525					
MM3464Z25	2.525	2.550	2.576					
MM3464A26	2.574	2.600	2.626					
MM3464Z26	2.624	2.650	2.677					
MM3464A27	2.673	2.700	2.727					
MM3464Z27	2.723	2.750	2.778					
MM3464A28	2.772	2.800	2.828					
MM3464Z28	2.822	2.850	2.879					
MM3464A29	2.871	2.900	2.929					
MM3464Z29	2.921	2.950	2.980					

Note5 : Dropout voltage Max. value in the input and it is confirmed that there is no output abnormal voltage impression the load 200mA in the model less than  $V_{OUT}=1.45V$ .

• Any products mentioned in this catalog are subject to any modification in their appearance and others for improvements without prior notification.  
 • The details listed here are not a guarantee of the individual products at the time of ordering. When using the products, you will be asked to check their specifications.

Model No.	Item							
	Output voltage				Dropout voltage			
	V <sub>OUT</sub> (V)				V <sub>IO</sub> (mV)			
	Measurement conditions	Min.	Typ.	Max.	Measurement conditions	Min.	Typ.	Max.
MM3464A30	I <sub>OUT</sub> =10mA	2.970	3.000	3.030	I <sub>OUT</sub> =200mA V <sub>OUT</sub> ≥1.5V V <sub>DD</sub> =V <sub>OUT</sub> (typ.)-0.2V			
MM3464Z30		3.020	3.050	3.081				
MM3464A31		3.069	3.100	3.131				
MM3464Z31		3.119	3.150	3.182				
MM3464A32		3.168	3.200	3.232				
MM3464Z32		3.218	3.250	3.283				
MM3464A33		3.267	3.300	3.333				
MM3464Z33		3.317	3.350	3.384				
MM3464A34		3.366	3.400	3.434				
MM3464Z34		3.416	3.450	3.485				
MM3464A35		3.465	3.500	3.535				
MM3464Z35		3.515	3.550	3.586				
MM3464A36		3.564	3.600	3.636				
MM3464Z36		3.614	3.650	3.687				
MM3464A37		3.663	3.700	3.737				
MM3464Z37		3.713	3.750	3.788				
MM3464A38		3.762	3.800	3.838				
MM3464Z38		3.812	3.850	3.889				
MM3464A39		3.861	3.900	3.939				
MM3464Z39		3.911	3.950	3.990				
MM3464A40		3.960	4.000	4.040				
MM3464Z40		4.010	4.050	4.091				
MM3464A41		4.059	4.100	4.141				
MM3464Z41		4.109	4.150	4.192				
MM3464A42		4.158	4.200	4.242				
MM3464Z42		4.208	4.250	4.293				
MM3464A43		4.257	4.300	4.343				
MM3464Z43		4.307	4.350	4.394				
MM3464A44		4.356	4.400	4.444				
MM3464Z44		4.405	4.450	4.495				
MM3464A45		4.455	4.500	4.545				
MM3464Z45		4.504	4.550	4.595				
MM3464A46	4.554	4.600	4.646					
MM3464Z46	4.603	4.650	4.696					
MM3464A47	4.653	4.700	4.747					
MM3464Z47	4.702	4.750	4.797					
MM3464A48	4.752	4.800	4.848					
MM3464Z48	4.801	4.850	4.898					
MM3464A49	4.851	4.900	4.949					
MM3464Z49	4.900	4.950	4.999					
MM3464A50	4.950	5.000	5.050					

• Any products mentioned in this catalog are subject to any modification in their appearance and others for improvements without prior notification.  
 • The details listed here are not a guarantee of the individual products at the time of ordering. When using the products, you will be asked to check their specifications.

## Measuring Circuit

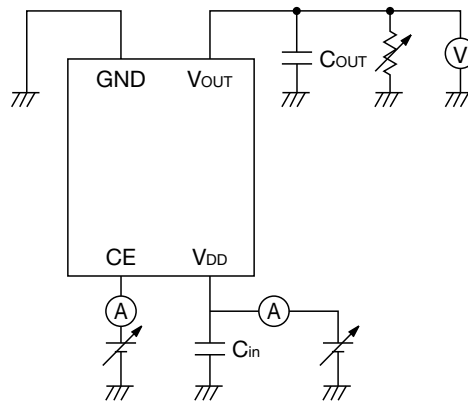

## Application Circuit

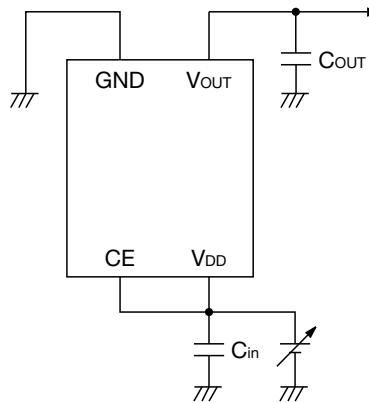

(Reference example of external parts)

- Output capacitor                      Ceramic capacitor 1.0 $\mu$ F
- Input capacitor                        Ceramic capacitor 1.0 $\mu$ F

\* Temperature Characteristics : B

· Note

1. The output capacitor is required between output and GND to prevent oscillation.
2. The ESR of capacitor must be defined in ESR stability area.  
It is possible to use a ceramic capacitor without ESR resistance for output.  
The ceramic capacitor must be used more than 1.0 $\mu$ F and B temperature characteristics.
3. The wire of Vcc and GND is required to print full ground plane for noise and stability.
4. The input capacitor must be connected a distance of less than 1cm from input pin.
5. In case the output voltage is above the input voltage, the overcurrent flow by internal parastic diode from output to input.

**Characteristics (Vo=1.0V)** (Except where noted otherwise  $V_{DD}=V_{OUT}(\text{typ.}) + 1V$ ,  $V_{CE}=V_{DD}$ ,  $T_a=25^\circ\text{C}$ )

**Output - Input voltage**

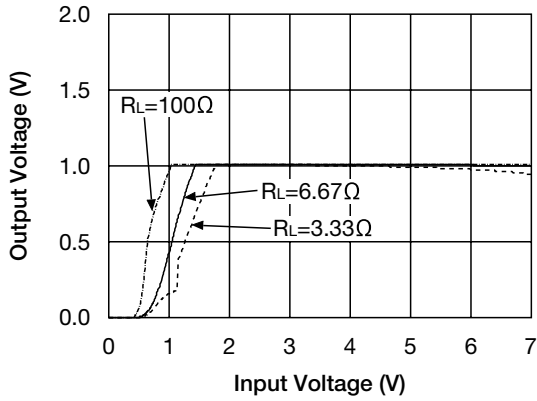

**Input current - Input voltage**

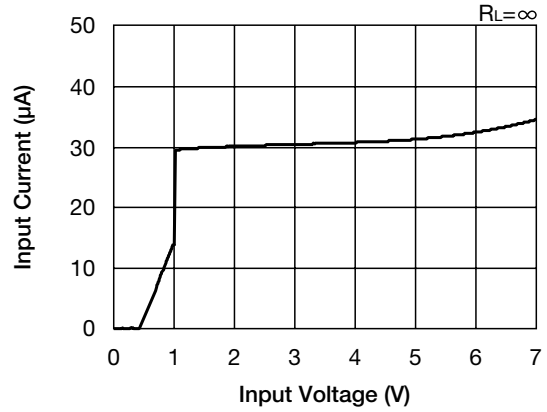

**Load regulation**

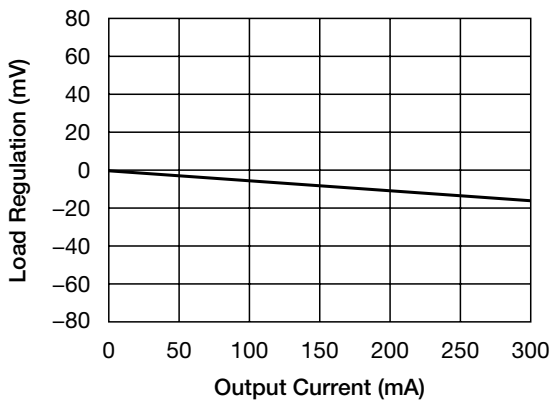

**Line regulation**

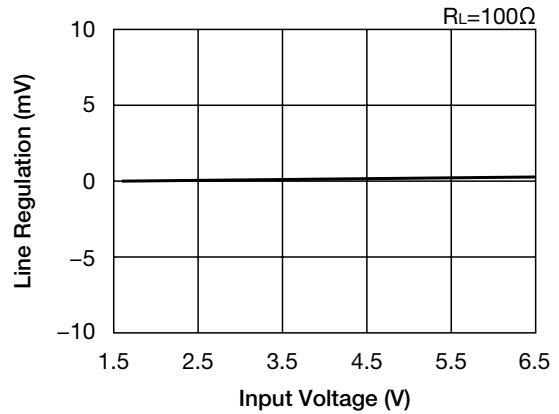

**Ripple Rejection**

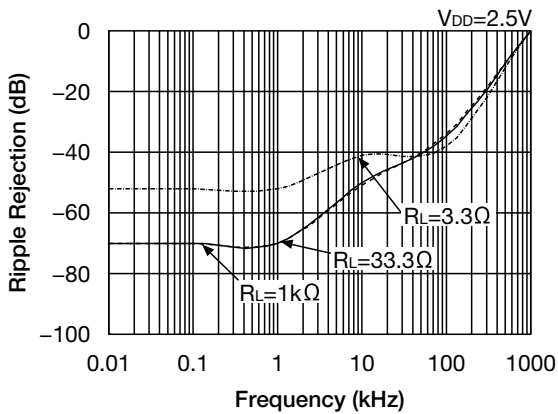

**Current Limit**

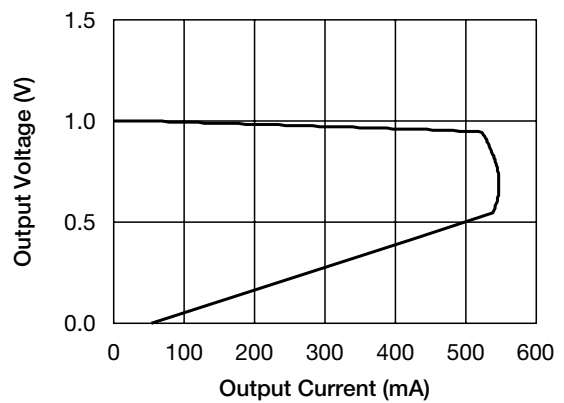

• Any products mentioned in this catalog are subject to any modification in their appearance and others for improvements without prior notification.  
 • The details listed here are not a guarantee of the individual products at the time of ordering. When using the products, you will be asked to check their specifications.



■ ESR stability area

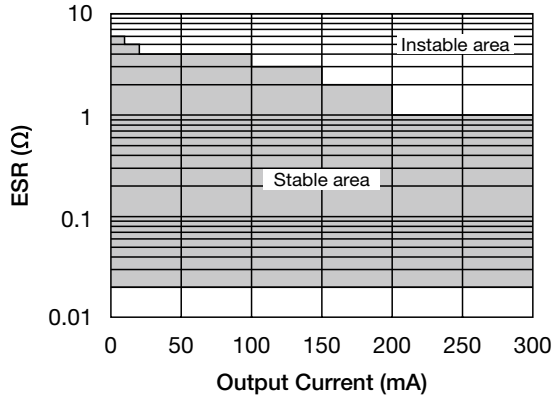

■  $V_{OUT}$  temperature coefficient

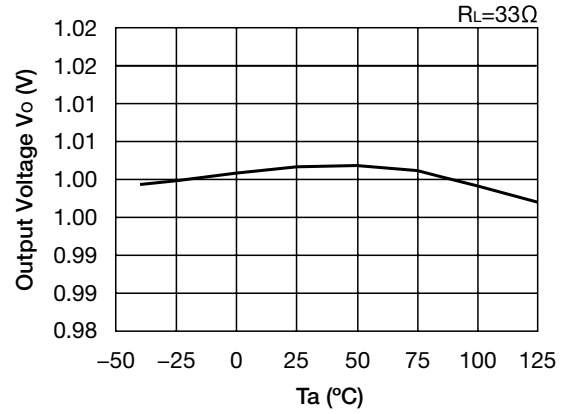

■ Load transient response ( $V_{DD}=V_o+1V$ ,  $V_{CE}=V_{DD}$ ,  $C_{in}=C_o=1\mu F$ )

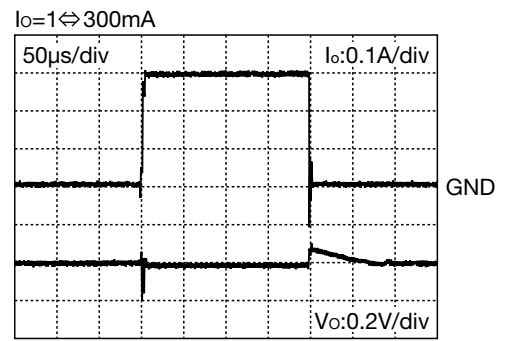
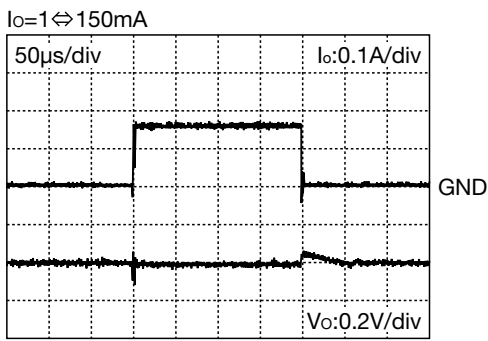

**Characteristics (Vo=3.0V)** (Except where noted otherwise  $V_{DD}=V_{OUT}(\text{typ.}) + 1V$ ,  $V_{CE}=V_{DD}$ ,  $T_a=25^\circ\text{C}$ )

**Output - Input voltage**

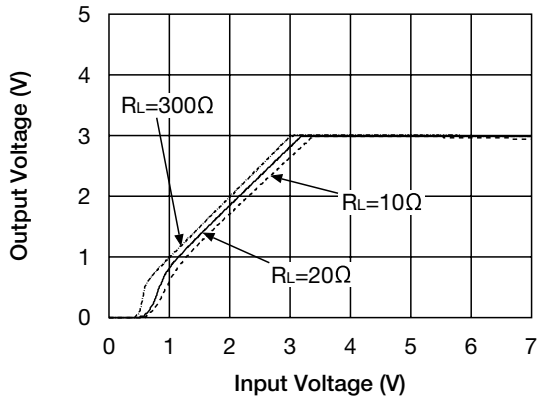

**Input current - Input voltage**

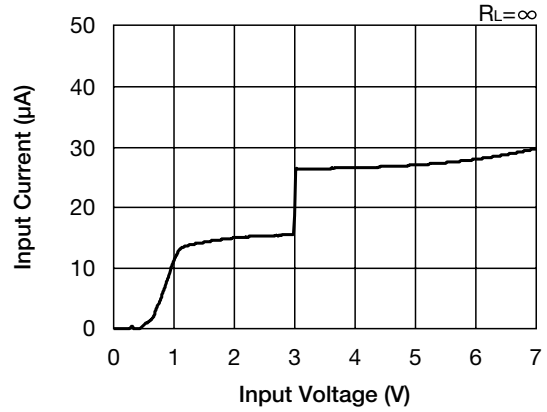

**Load regulation**

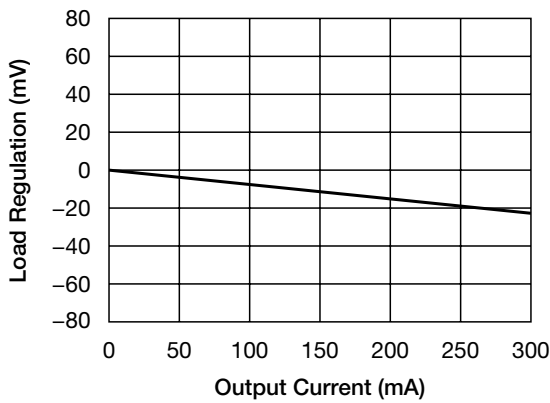

**Line regulation**

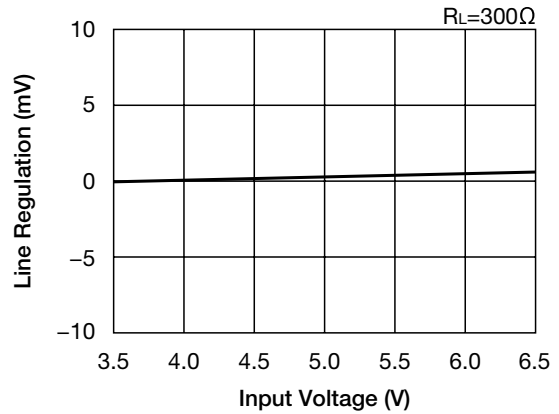

**Ripple Rejection**

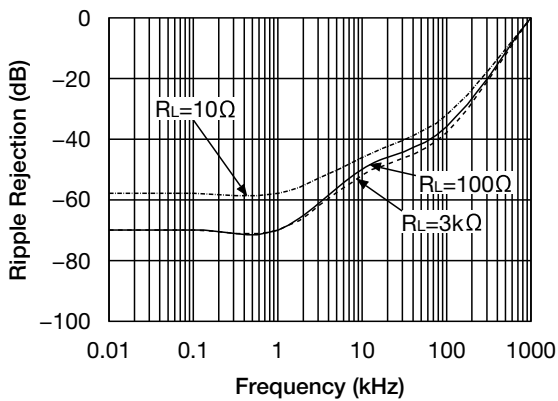

**Current Limit**

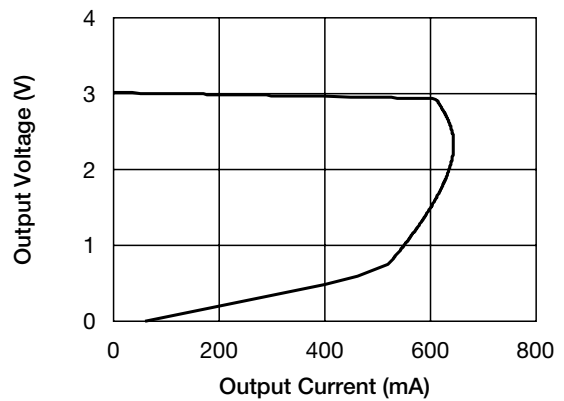

• Any products mentioned in this catalog are subject to any modification in their appearance and others for improvements without prior notification.  
 • The details listed here are not a guarantee of the individual products at the time of ordering. When using the products, you will be asked to check their specifications.

Dropout voltage - Output voltage

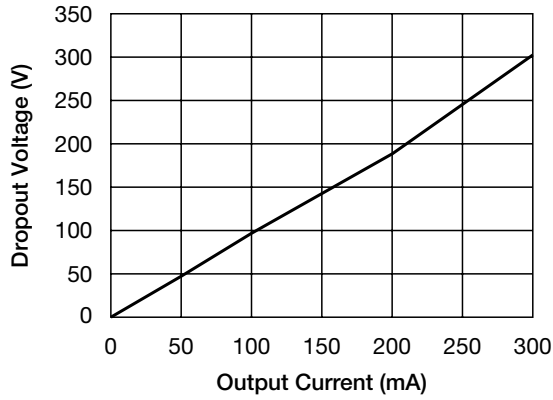

ESR stability area

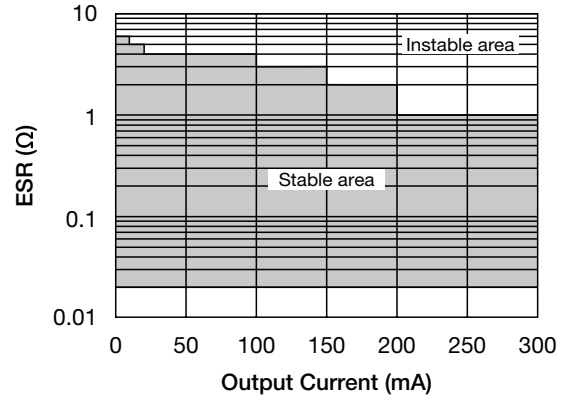

V<sub>OUT</sub> temperature coefficient

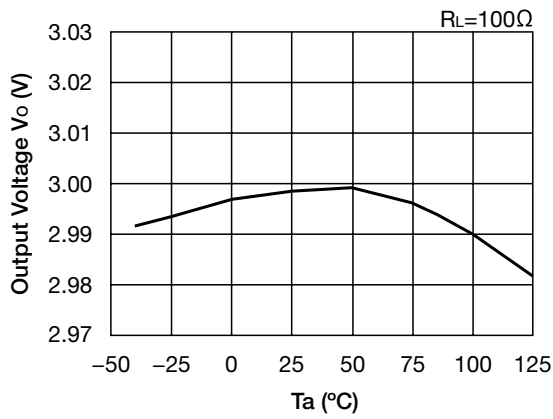

Load transient response (V<sub>DD</sub>=Vo+1V, V<sub>CE</sub>=V<sub>DD</sub>, Cin=Co=1μF)

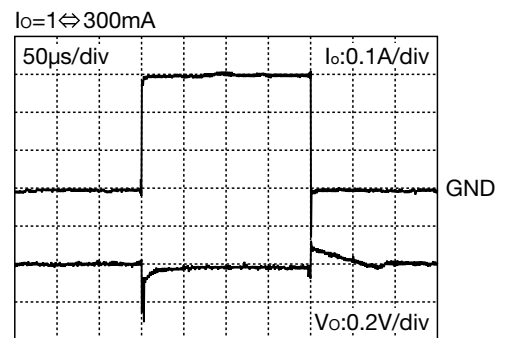
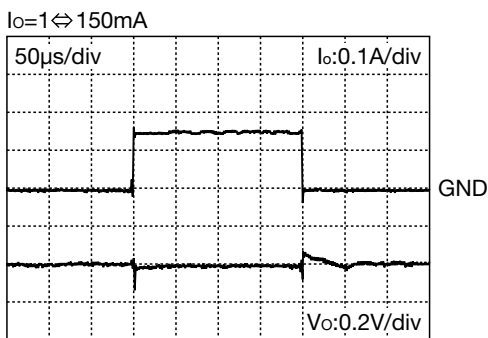

**Characteristics (Vo=5.0V)** (Except where noted otherwise  $V_{DD}=V_{OUT}(\text{typ.}) + 1V$ ,  $V_{CE}=V_{DD}$ ,  $T_a=25^\circ\text{C}$ )

**Output - Input voltage**

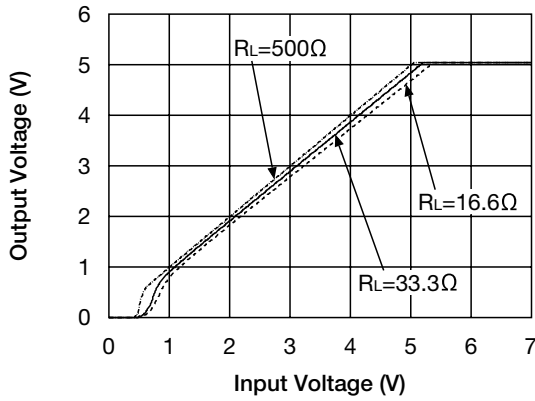

**Input current - Input voltage**

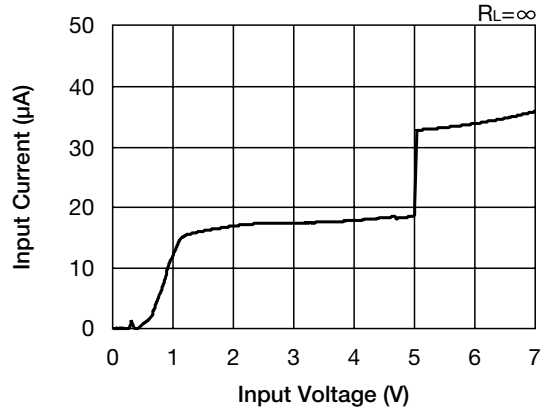

**Load regulation**

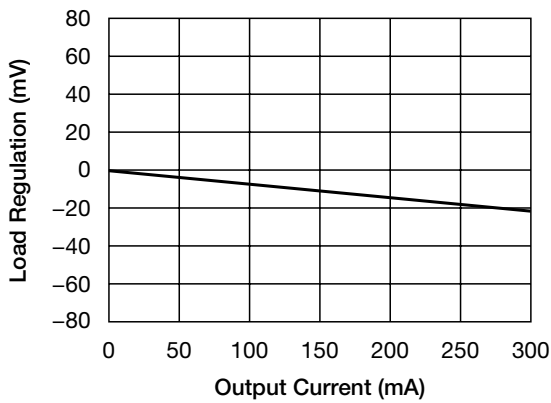

**Line regulation**

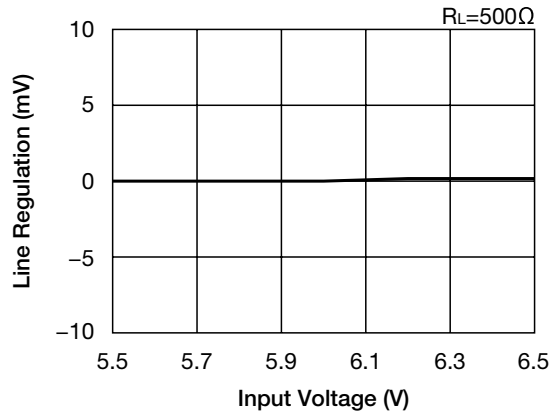

**Ripple Rejection**

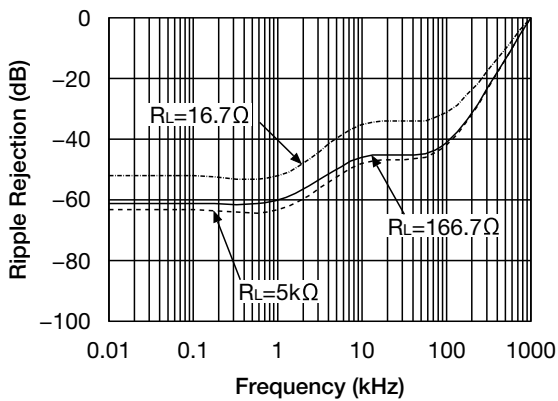

**Current Limit**

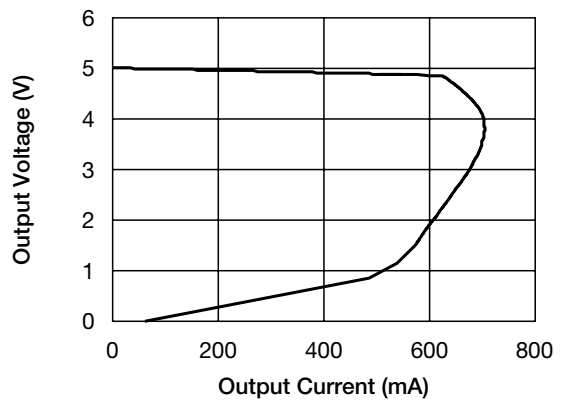

• Any products mentioned in this catalog are subject to any modification in their appearance and others for improvements without prior notification.  
 • The details listed here are not a guarantee of the individual products at the time of ordering. When using the products, you will be asked to check their specifications.

Dropout voltage - Output voltage

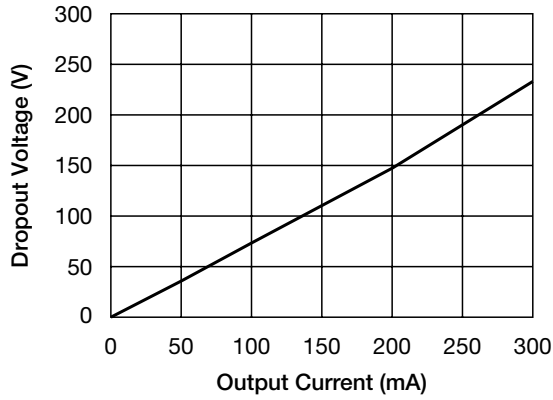

ESR stability area

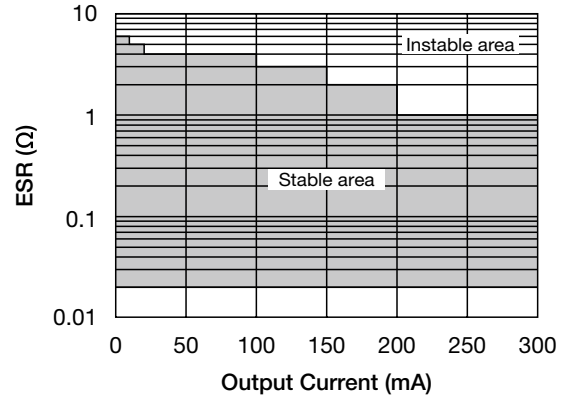

V<sub>OUT</sub> temperature coefficient

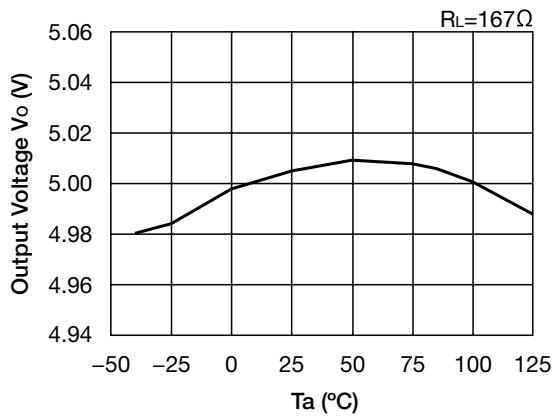

Load transient response (V<sub>DD</sub>=Vo+1V, V<sub>CE</sub>=V<sub>DD</sub>, Cin=Co=1μF)

