

Low-Saturation voltage 300mA LDO Monolithic IC MM334x Series

Outline

This IC is a 300mA LDO with an ultra-low saturation voltage.

This device features a 300 mA current capability and high-value ripple rejections of 70dB typ. for protection, it includes an over-current protection circuit and a thermal shutdown circuit.

Features

| | |
|----------------------------|---|
| 1. Supply Current | 45 μ A typ. (No-load) 0.1 μ A typ. (OFF) |
| 2. Output Voltage Range | 1.2V~5.0V |
| 3. Output Voltage accuracy | $V_{OUT} \pm 2\%$ |
| 4. Dropout Voltage | 0.16V ($I_O=300\text{mA}$) |
| 5. Line Regulation | 0.02%/V |
| 6. Load Regulation | 50mV typ. ($I_O=1\sim 300\text{mA}$) |
| 7. Ripple rejection | 70dB typ. ($f=1\text{kHz}$) |
| 8. Thermal shutdown | |
| 9. Dropout capacitor | 1 μ F |

Package

SSON-6A
SOP-8D
SOT-25A

Applications

1. Mobile phones
2. Digital cameras
3. TVs
4. DVD·Blu-ray recorder

Block Diagram

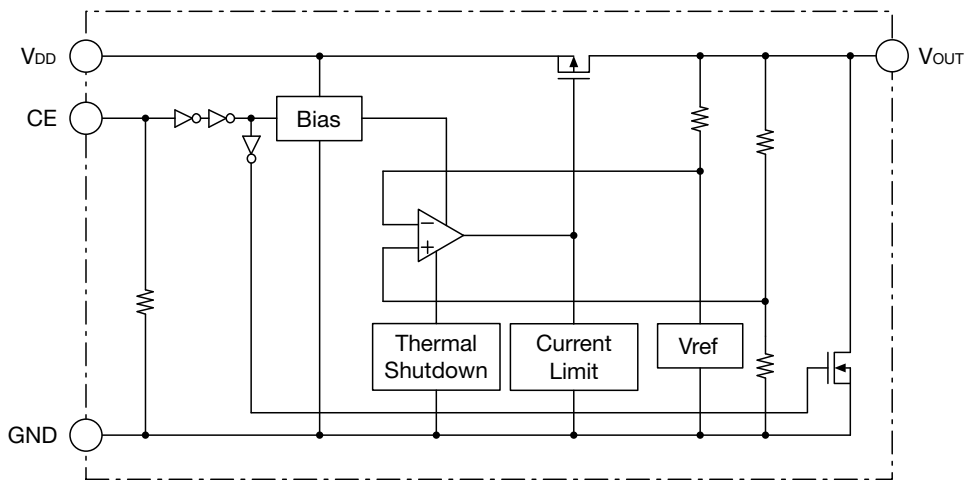

Pin Assignment

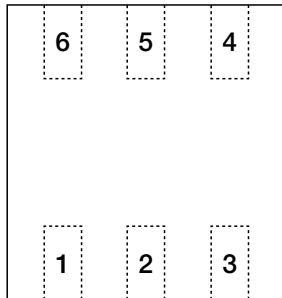

SSON-6A
(TOP VIEW)

| | |
|---|-----------|
| 1 | V_{DD} |
| 2 | NC |
| 3 | V_{OUT} |
| 4 | NC |
| 5 | GND |
| 6 | CE |

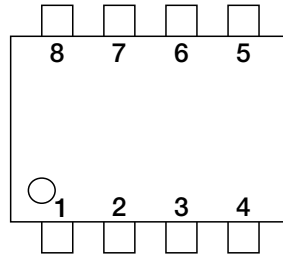

SOP-8D
(TOP VIEW)

| | |
|---|----------|
| 1 | V_O |
| 2 | NC |
| 3 | GND |
| 4 | NC |
| 5 | CE |
| 6 | NC |
| 7 | NC |
| 8 | V_{DD} |

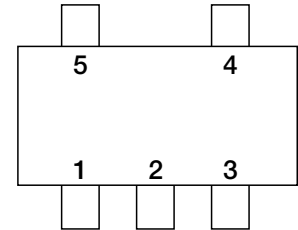

SOT-25A
(TOP VIEW)

| | |
|---|-----------|
| 1 | V_{DD} |
| 2 | GND |
| 3 | CE |
| 4 | NC |
| 5 | V_{OUT} |

• Any products mentioned in this catalog are subject to any modification in their appearance and others for improvements without prior notification.
 • The details listed here are not a guarantee of the individual products at the time of ordering. When using the products, you will be asked to check their specifications.

Pin Description

SSON-6A

| Pin No. | Pin name | Functions | |
|---|------------------|--------------------|------------------|
| 1 | V _{DD} | Voltage-supply pin | |
| 2,4 | NC | No connection | |
| 3 | V _{OUT} | Output pin | |
| 5 | GND | GND pin | |
| 6 | CE | ON/OFF-Control pin | |
| | | CE | V _{OUT} |
| | | Low | OFF |
| | | High | ON |
| Connect CE pin with V _{DD} pin, when it is not used. | | | |

SOP-8D

| Pin No. | Pin name | Functions | |
|---|------------------|--------------------|------------------|
| 1 | V _{OUT} | Output pin | |
| 2,4 | NC | No connection | |
| 3 | GND | GND pin | |
| 5 | CE | ON/OFF-Control pin | |
| | | CE | V _{OUT} |
| | | Low | OFF |
| | | High | ON |
| Connect CE pin with V _{DD} pin, when it is not used. | | | |
| 6,7 | NC | No connection | |
| 8 | V _{DD} | Voltage-supply pin | |

SOT-25A

| Pin No. | Pin name | Functions | |
|---|------------------|--------------------|------------------|
| 1 | V _{DD} | Voltage-supply pin | |
| 2 | GND | GND pin | |
| 3 | CE | ON/OFF-Control pin | |
| | | CE | V _{OUT} |
| | | Low | OFF |
| | | High | ON |
| Connect CE pin with V _{DD} pin, when it is not used. | | | |
| 4 | NC | No connection | |
| 5 | V _{OUT} | Output pin | |

Absolute Maximum Ratings (Except where noted otherwise Ta=25°C)

| Item | Symbol | Ratings | Units |
|---------------------|-------------------|---------------------------|---------|
| Storage Temperature | T _{STG} | -55~+150 | °C |
| Supply Voltage | V _{DD} | 6.5 | V |
| CE input Voltage | V _{CE} | -0.3~V _{DD} +0.3 | V |
| Output Voltage | V _{OUT} | -0.3~V _{DD} +0.3 | V |
| Output Current | I _{omax} | 350 | mA |
| Power Dissipation | Pd | 950(Note1) | SOP-8D |
| | | 180(Note2) | SSON-6A |
| | | 350(Note3) | SOT-25A |
| | | | mW |

Note1 : With the double sided PC Board of glass epoxy
(Copper plane 80%, 192 × 142 × 1.2^tmm)

Note2 : With the double sided PC Board of glass epoxy
(Copper plane 80%, 25 × 252 × 1.6^tmm)

Note3 : With the double sided PC Board of glass epoxy
(Copper plane 60%, 25 × 25 × 1.6^tmm)

Recommended Operating Conditions (Except where noted otherwise Ta=25°C)

| Item | Symbol | Ratings | Units |
|-------------------------------|------------------|---------|-------|
| Operating Ambient Temperature | T _{JOP} | -40~85 | °C |
| Operating Voltage | V _{OP} | 2~6 | V |
| Output Current | I _O | 0~300 | mA |

Electrical Characteristics 1 (Except where noted otherwise V_{DD}=V_{OUT}(typ.)+1V, V_{CE}=V_{DD}, Ta=25°C)

| Item | Symbol | Measurement conditions | Min. | Typ. | Max. | Units |
|--|-----------------------|---|-------|------|-----------------|-------------------|
| Input Current(OFF) | I _{DDoff} | V _{CE} =0V | | 0.1 | 1.0 | μA |
| No-Load Input Current | I _{DD} | I _{OUT} =0mA | | 45 | 70 | μA |
| Output Voltage | V _{OUT} | I _{OUT} =30mA | ×0.98 | | ×1.02 | V |
| Line Regulation | V _{LINE} | V _{DD} =V _O (typ.)+0.5~6V, I _{OUT} =30mA (V _{OUT} ≤1.6V, V _{DD} =2.2~6V) | | 0.02 | 0.10 | %/V |
| Load Regulation | V _{LOAD} | 1mA≤I _{OUT} ≤300mA | | 50 | 120 | mV |
| Dropout Voltage | V _{IO} | Please refer to another page | | | | V |
| Ripple Rejection 1 (Note4) | RR1 | f=1kHz, V _{ripple} =0.5V, I _{OUT} =30mA (V _{OUT} ≤1.7V, V _{DD} =V _{OUT} +1.2V) | | 70 | | dB |
| Ripple Rejection 2 (Note4) | RR2 | f=10kHz, V _{ripple} =0.5V, I _{OUT} =30mA (V _{OUT} ≤1.7V, V _{DD} =V _{OUT} +1.2V) | | 50 | | dB |
| V _{OUT} Temperature Coefficient (Note4) | ΔV _{OUT} /ΔT | I _{OUT} =30mA -40°C≤T _{OP} ≤85°C | | ±100 | | ppm/°C |
| Output Noise Voltage (Note4) | V _n | f _{BW} =10~100kHz I _{OUT} =30mA | | 30 | | μV _{rms} |
| Output Short-circuit Current (Note4) | I _{lim} | V _{OUT} =0V | | 40 | | mA |
| CE Pull-down Resistance | R _{pd} | | 0.7 | 2 | 8 | MΩ |
| CE High Threshold Voltage | V _{CEH} | | 1.5 | | V _{DD} | V |
| CE Low Threshold Voltage | V _{CEL} | | 0 | | 0.3 | V |
| Output NMOS ON resistance | R _{DON} | V _{CE} =0V V _{DD} =4V(V _{OUT} <3V) | | 60 | | Ω |

Note4 : The parameter is guaranteed by design.

Electrical Characteristics 2 (Except where noted otherwise $V_{DD}=V_o(\text{typ.})+1V$, $V_{CE}=V_{DD}$, $T_a=25^\circ\text{C}$)

| Output Voltage Vo1, Vo2 | Item | | | | | | | |
|----------------------------|------------------------|-------|-------|-------|---|------|------|------|
| | Output Voltage | | | | Dropout Voltage | | | |
| | Vo1, Vo2 (V) | | | | Vio1, Vio2 (V) | | | |
| | Measurement Conditions | Min. | Typ. | Max. | Measurement Conditions | Min. | Typ. | Max. |
| 1.2V | 1mA ≤ Io ≤ 30mA | 1.170 | 1.200 | 1.230 | SSON-6A(Note5) SOP-8D(Note6) SOT-25A(Note5) | | | |
| 1.3V | | 1.270 | 1.300 | 1.330 | | | | |
| 1.4V | | 1.370 | 1.400 | 1.430 | | | | |
| 1.5V | | 1.470 | 1.500 | 1.530 | Io=300mA | | 0.26 | 0.52 |
| 1.6V | | 1.568 | 1.600 | 1.632 | | | 0.24 | 0.46 |
| 1.7V | | 1.666 | 1.700 | 1.734 | | | 0.22 | 0.40 |
| 1.8V | | 1.764 | 1.800 | 1.836 | 1.8V ≤ Vo ≤ 2.0V Io=300mA | | 0.20 | 0.30 |
| 1.9V | | 1.862 | 1.900 | 1.938 | | | | |
| 2.0V | | 1.960 | 2.000 | 2.040 | | | | |
| 2.1V | | 2.058 | 2.100 | 2.142 | 2.1V ≤ Vo ≤ 2.7V Io=300mA | | 0.18 | 0.27 |
| 2.2V | | 2.156 | 2.200 | 2.244 | | | | |
| 2.3V | | 2.254 | 2.300 | 2.346 | | | | |
| 2.4V | | 2.352 | 2.400 | 2.448 | | | | |
| 2.5V | | 2.450 | 2.500 | 2.550 | | | | |
| 2.6V | | 2.548 | 2.600 | 2.652 | | | | |
| 2.7V | | 2.646 | 2.700 | 2.754 | | | | |
| 2.8V | | 2.744 | 2.800 | 2.856 | 2.5V ≤ Vo ≤ 5.0V Io=300mA | | 0.16 | 0.23 |
| 2.9V | | 2.842 | 2.900 | 2.958 | | | | |
| 3.0V | | 2.940 | 3.000 | 3.060 | | | | |
| 3.1V | | 3.038 | 3.100 | 3.162 | | | | |
| 3.2V | | 3.136 | 3.200 | 3.264 | | | | |
| 3.3V | | 3.234 | 3.300 | 3.366 | | | | |
| 3.4V | | 3.332 | 3.400 | 3.468 | | | | |
| 3.5V | | 3.430 | 3.500 | 3.570 | | | | |
| 3.6V | | 3.528 | 3.600 | 3.672 | | | | |
| 3.7V | | 3.626 | 3.700 | 3.774 | | | | |
| 3.8V | | 3.724 | 3.800 | 3.876 | | | | |
| 3.9V | | 3.822 | 3.900 | 3.978 | | | | |
| 4.0V | | 3.920 | 4.000 | 4.080 | | | | |
| 4.1V | | 4.018 | 4.100 | 4.182 | | | | |
| 4.2V | 4.116 | 4.200 | 4.284 | | | | | |
| 4.3V | 4.214 | 4.300 | 4.386 | | | | | |
| 4.4V | 4.312 | 4.400 | 4.488 | | | | | |
| 4.5V | 4.410 | 4.500 | 4.590 | | | | | |
| 4.6V | 4.508 | 4.600 | 4.692 | | | | | |
| 4.7V | 4.606 | 4.700 | 4.794 | | | | | |
| 4.8V | 4.704 | 4.800 | 4.896 | | | | | |
| 4.9V | 4.802 | 4.900 | 4.998 | | | | | |
| 5.0V | 4.900 | 5.000 | 5.100 | | | | | |

Note5 : The parameter is not guaranteed in the model Vo=1.4V or less.

Note6 : The parameter is not guaranteed in the model less than Vo=1.4V.

Measuring Circuit

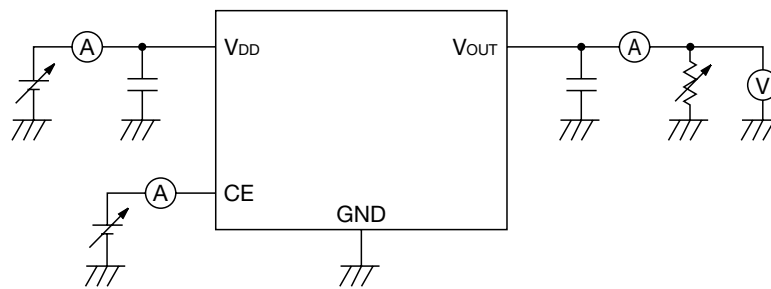

Application Circuit

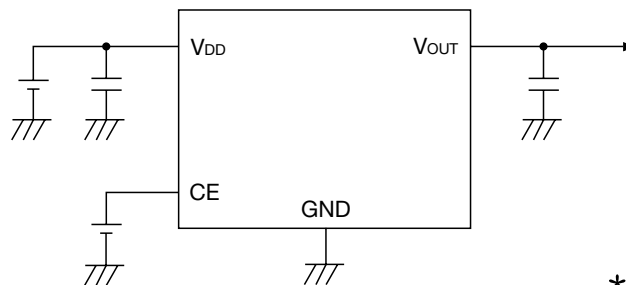

* Temperature Characteristics : B

(Reference example of external parts)

- Output capacitor Ceramic capacitor 1 μ F
- Input capacitor Ceramic capacitor 1 μ F

· Note

1. The output capacitor is required between output and GND to prevent oscillation.
2. The ESR of capacitor must be defined in ESR stability area.
It is possible to use a ceramic capacitor without ESR resistance for output.
The ceramic capacitor must be used more than 1.0 μ F or and B temperature characteristics.
3. The wire of Vcc and GND is required to print full ground plane for noise and stability.
4. The input capacitor must be connected a distance of less than 1cm from input pin.
5. In case the output voltage is above the input voltage, the overcurrent flow by internal parastic diode from output to input.

Characteristics (Vo=1.2V) (Except where noted otherwise $V_{DD}=V_{OUT}(\text{typ.}) + 1V$, $V_{CE}=V_{DD}$, $T_a=25^\circ\text{C}$)

Output - Input voltage

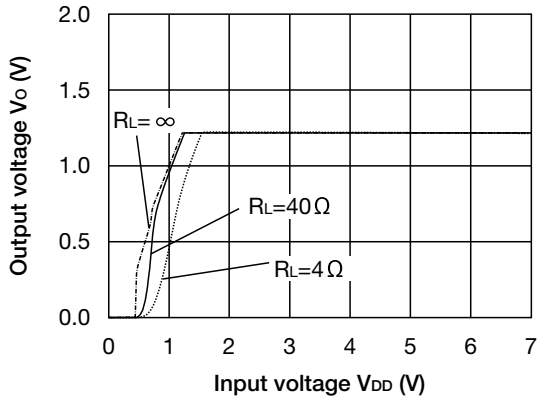

Input current - Input voltage

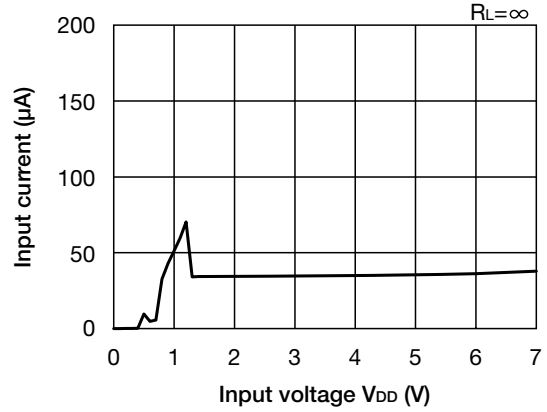

Output voltage - Output current

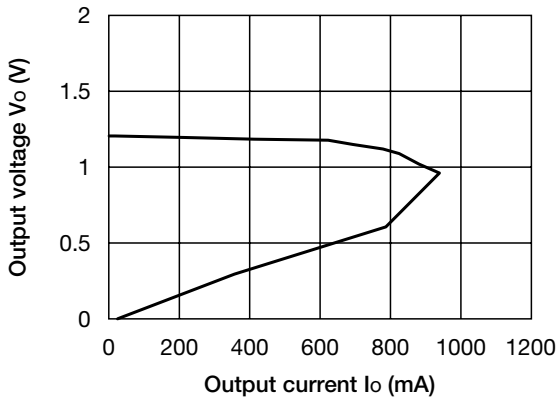

Load regulation

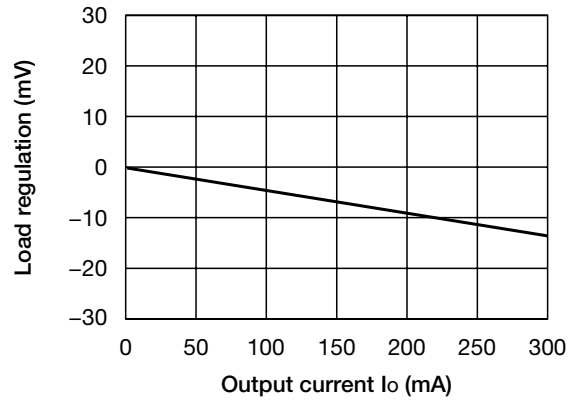

Line regulation

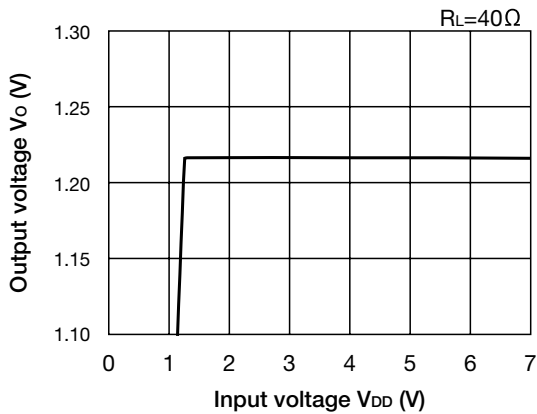

Output voltage - Ambient temperature

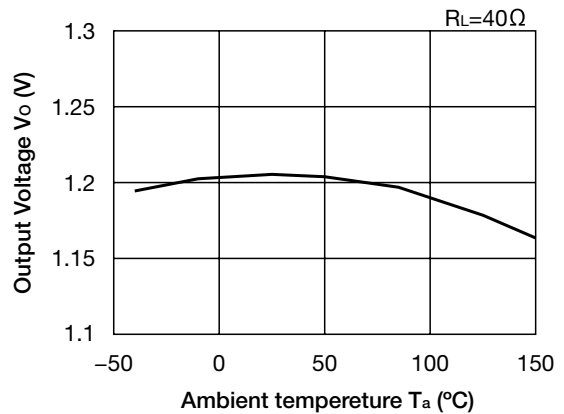

■ Ripple Rejection

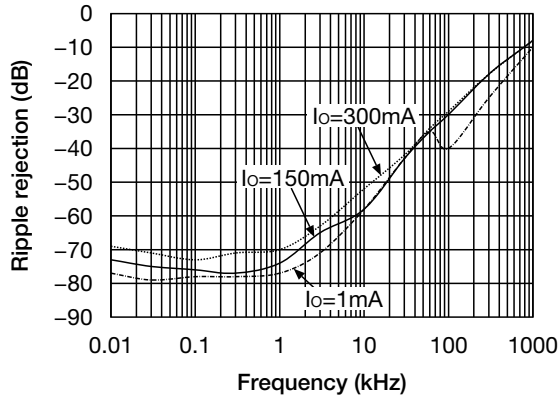

■ ESR Stable area

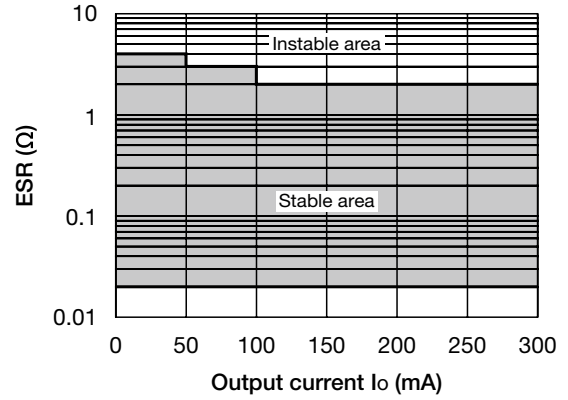

■ Load transient response ($I_o = 1 \rightarrow 150\text{mA}$)

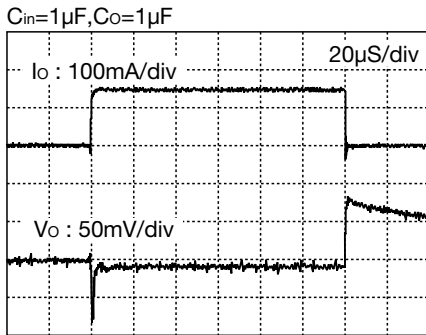

■ Load transient response ($I_o = 1 \rightarrow 300\text{mA}$)

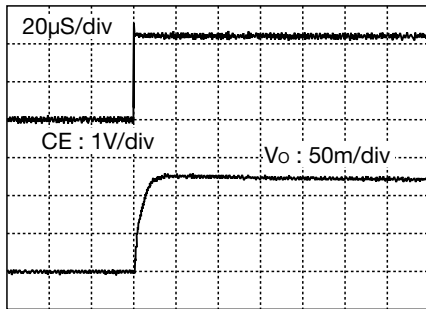
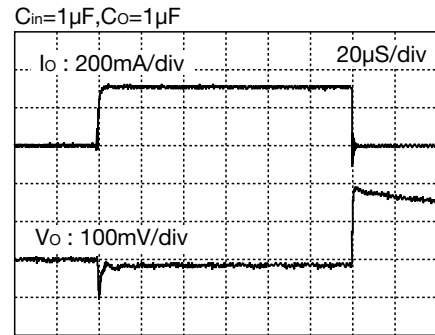

Characteristics (Vo=3.0V) (Except where noted otherwise $V_{DD}=V_{OUT} (typ.) +1V$, $V_{CE}=V_{DD}$, $T_a=25^{\circ}C$)

Output - Input voltage

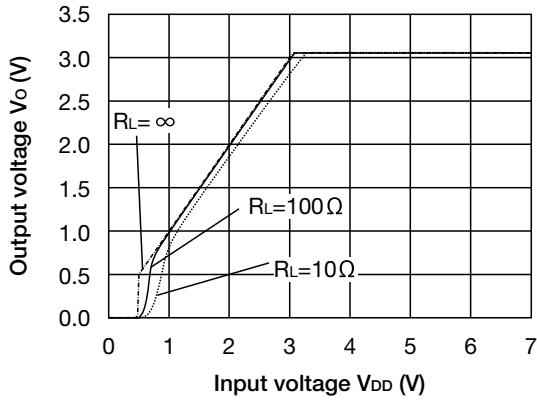

Input current - Input voltage

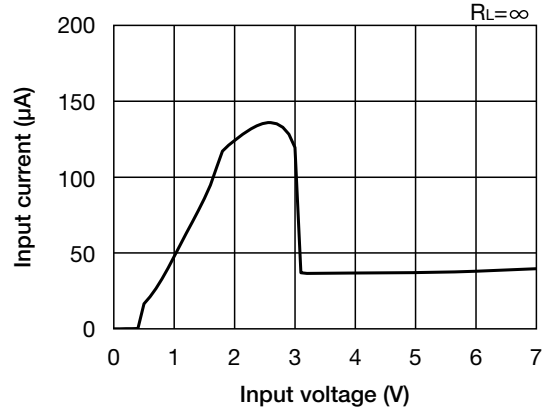

Output voltage - Output current

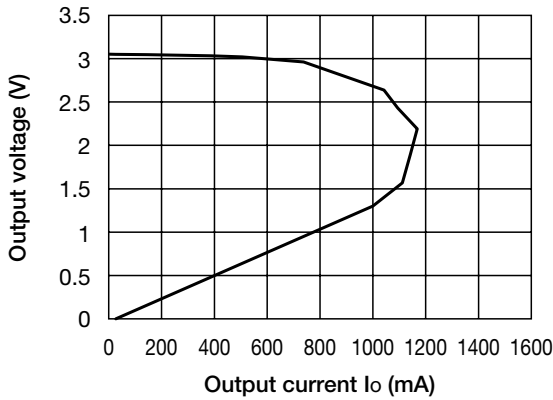

Load regulation

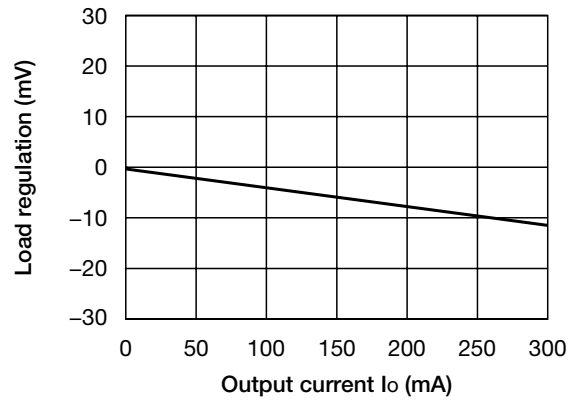

Line regulation

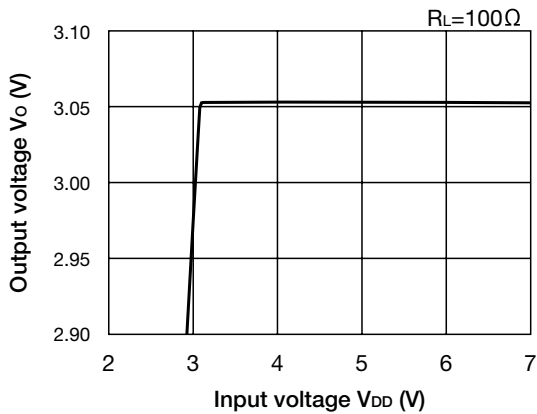

Dropout voltage

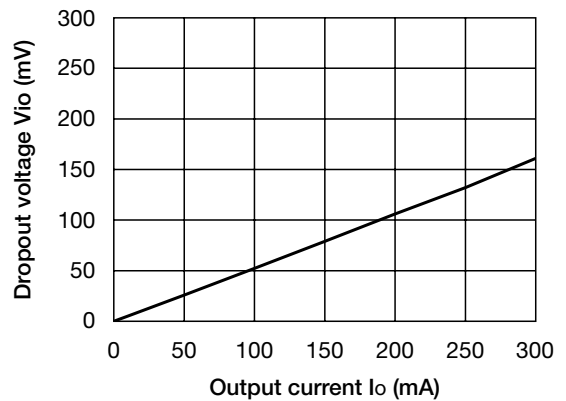

Ripple Rejection

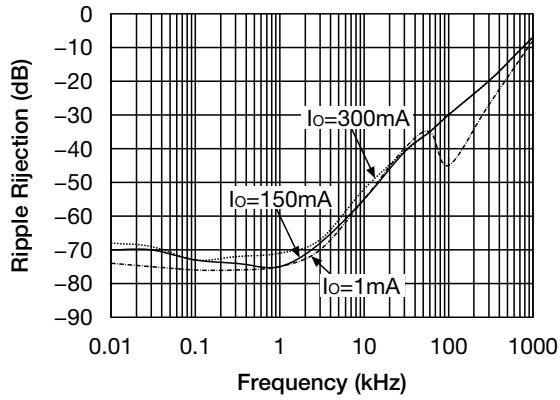

Output voltage - Ambient temperature

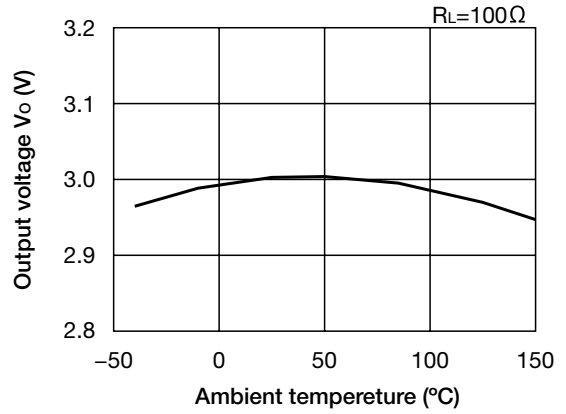

Load transient response ($I_o = 1 \rightarrow 150\text{mA}$)

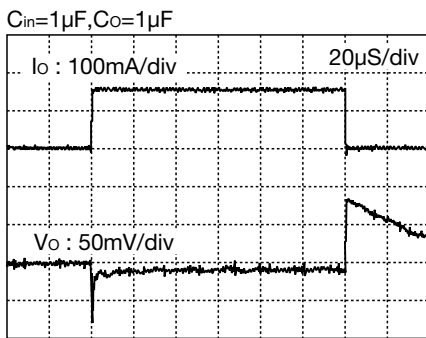

Load transient response ($I_o = 1 \rightarrow 300\text{mA}$)

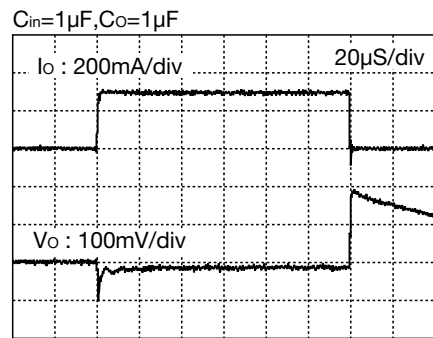

ESR Stable area

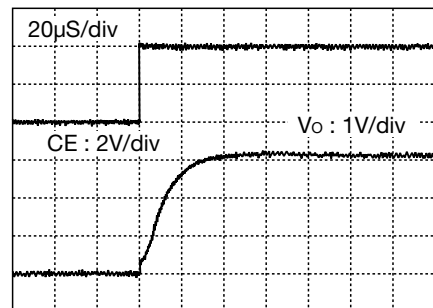
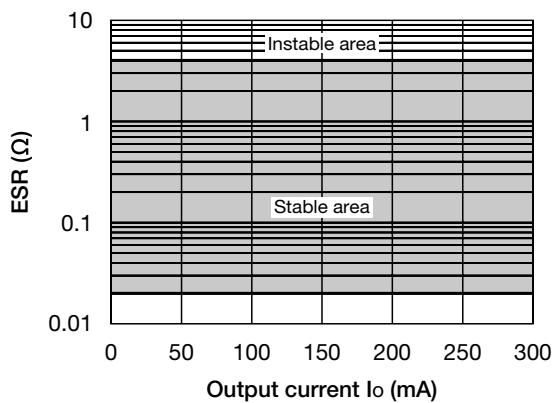

Characteristics (Vo=5.0V) (Except where noted otherwise V_{DD}=V_{OUT} (typ.) +1V, V_{CE}=V_{DD}, Ta=25°C)

Output - Input voltage

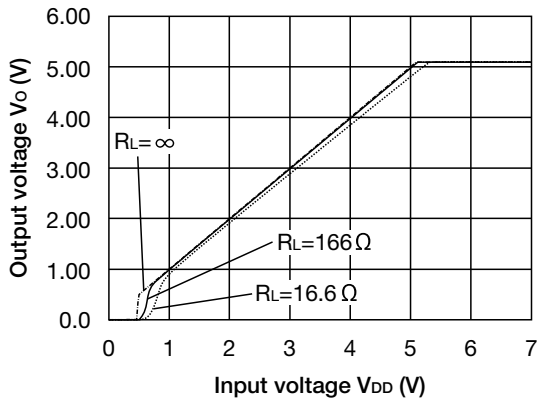

Input current - Input voltage

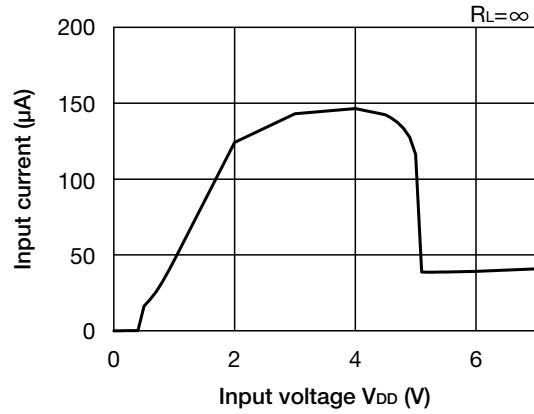

Output voltage - Output current

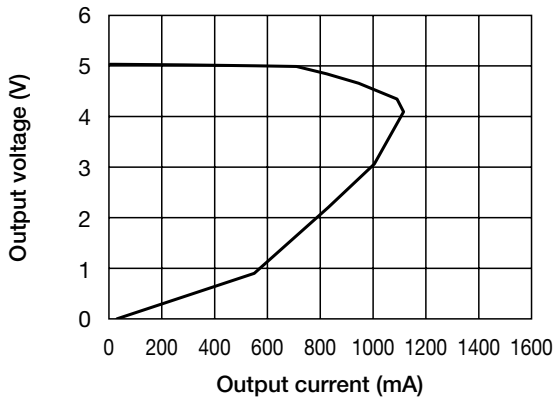

Load regulation

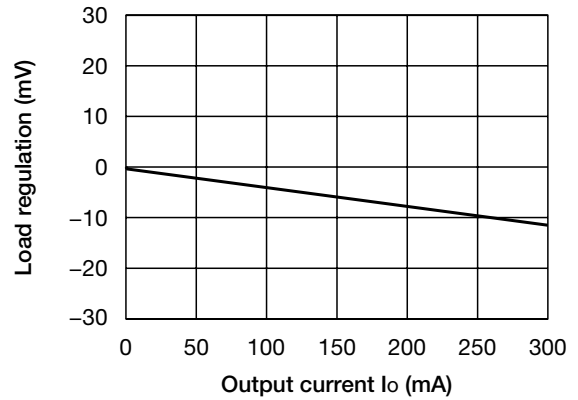

Line regulation

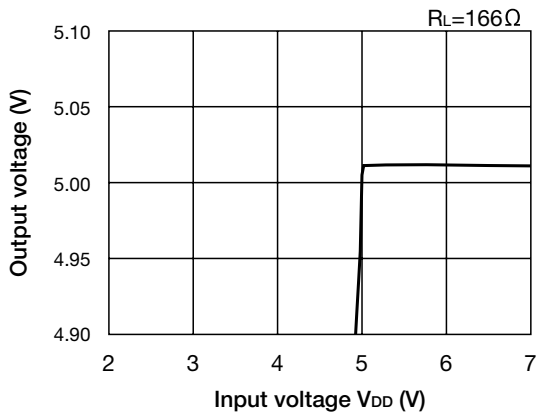

Dropout voltage

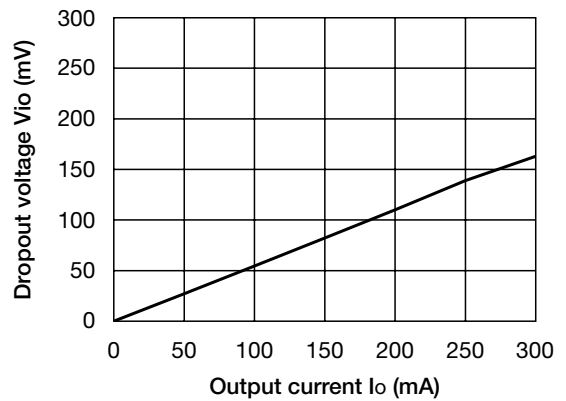

• Any products mentioned in this catalog are subject to any modification in their appearance and others for improvements without prior notification.
 • The details listed here are not a guarantee of the individual products at the time of ordering. When using the products, you will be asked to check their specifications.

Ripple Rejection

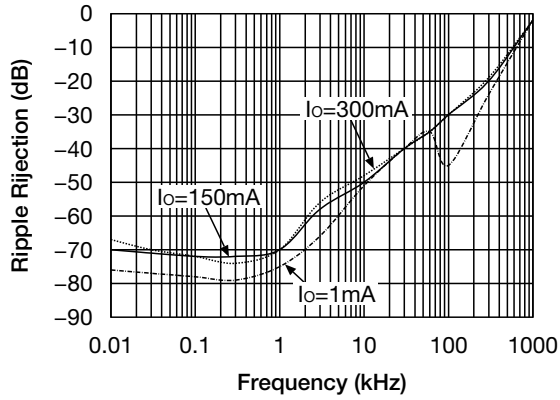

Output voltage - Ambient temperature

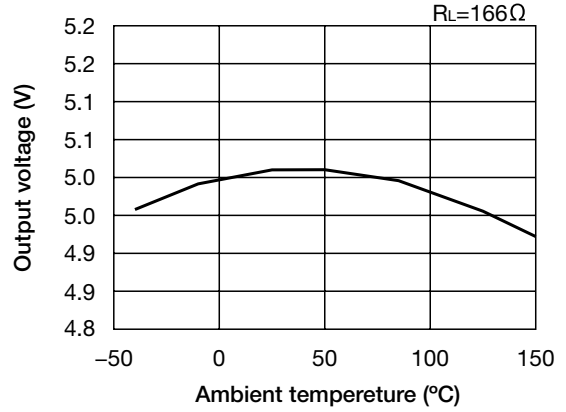

Load transient response ($I_o = 1 \rightarrow 150\text{mA}$)

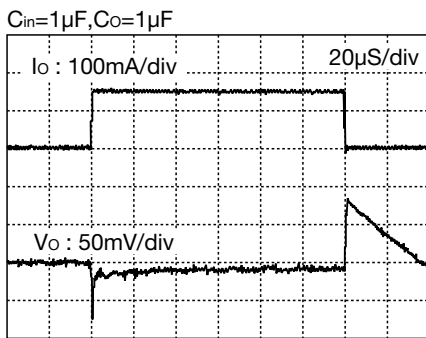

Load transient response ($I_o = 1 \rightarrow 300\text{mA}$)

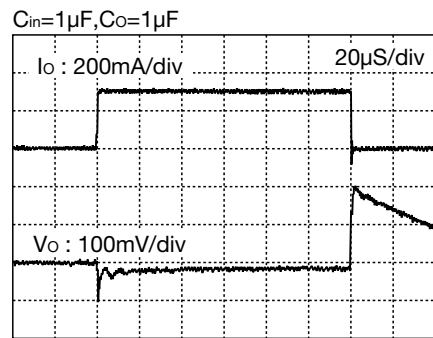

ESR Stable area

