

DATA SHEET

SKY12347-362LF: DC-3.0 GHz Six-Bit Digital Attenuator with Serial or Parallel Driver (0.5 dB LSB)

Applications

- Cellular, 3G/4G, WiMAX, and LTE Infrastructures

Features

- Broadband operation: DC to 3.0 GHz
- Attenuation: 31.5 dB with 0.5 dB LSB
- TTL/CMOS-compatible serial, parallel, or latched parallel control interface
- Single supply voltage: +3.3 or +5 V
- Small, QFN (24-pin, 4 x 4 mm) package (MSL1, 260 °C per JEDEC J-STD-020)



Skyworks Green™ products are compliant with all applicable legislation and are halogen-free. For additional information, refer to *Skyworks Definition of Green™*, document number SQ04-0074.

Description

The SKY12347-362LF is a GaAs pHEMT six-bit broadband digital attenuator with a 0.5 dB Least Significant Bit (LSB). A Transistor-to-Transistor Logic (TTL)/CMOS-compatible, dual-mode serial or parallel interface controller is integrated into the device.

The attenuator features low insertion loss, excellent attenuation accuracy, a 31.5 dB attenuation range, and high linearity performance. The SKY12347-362LF is an ideal choice for a wide variety of cellular 3G and 4G infrastructure applications.

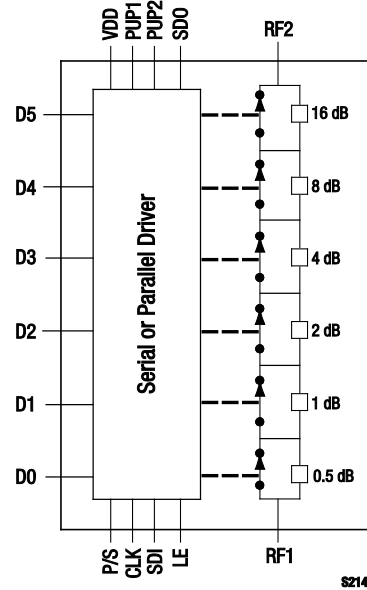

Figure 1. SKY12347-362LF Block Diagram

Attenuation is controlled by a Serial Peripheral Interface (SPI). Depending on the SPI sequence applied to the SDI pin, the attenuation state between the RF1 and RF2 pins can vary between a low insertion loss state or up to 31.5 dB. The D0 through D5 DC control pins determine the attenuation state if parallel mode is enabled.

The device is provided in a 4 x 4 mm, 24-pin Quad Flat No-Lead (QFN) package. A functional block diagram is shown in Figure 1. The pin configuration and package are shown in Figure 2. Signal pin assignments and functional pin descriptions are provided in Table 1.

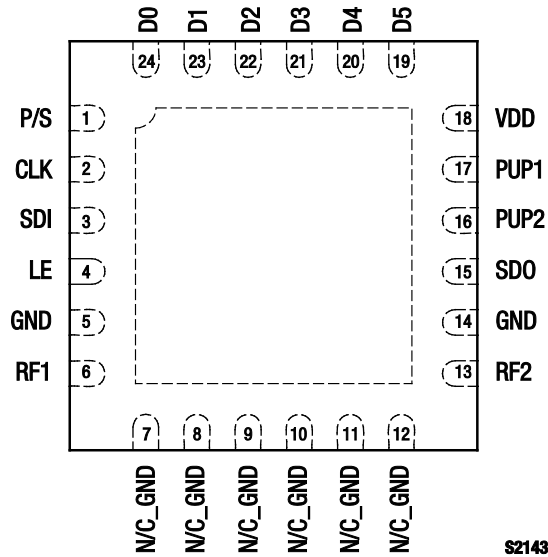

Figure 2. SKY12347-362LF Pinout – 24-Pin QFN (Top View)

Table 1. SKY12347-362LF Signal Descriptions

Pin #	Name	Description	Pin #	Name	Description
1	P/S	Selects serial or parallel operation. Logic low enables parallel mode.	13	RF2	RF input/output to digital attenuator.
2	CLK	Serial clock input	14	GND	Ground
3	SDI	Serial data input	15	SD0	Serial data output
4	LE	On rising edge of pulse, shifts six most recent clocked-in bits to set attenuation state. In parallel mode, if latch enable is logic high, changes to pins 19 to 24 occur directly. If latch enable is logic low, the attenuator does not change states until the signal is raised.	16	PUP2	Sets device power-up attenuation state. See Table 7.
5	GND	Ground	17	PUP1	Sets device power-up attenuation state. See Table 7.
6	RF1	RF input/output to digital attenuator.	18	VDD	DC power supply
7	NC_GND	No connection. Can be grounded without affecting performance.	19	D5	TTL/CMOS DC control pin for parallel mode operation. D5 is MSB.
8	NC_GND	No connection. Can be grounded without affecting performance.	20	D4	TTL/CMOS DC control pin for parallel mode operation
9	NC_GND	No connection. Can be grounded without affecting performance.	21	D3	TTL/CMOS DC control pin for parallel mode operation
10	NC_GND	No connection. Can be grounded without affecting performance.	22	D2	TTL/CMOS DC control pin for parallel mode operation
11	NC_GND	No connection. Can be grounded without affecting performance.	23	D1	TTL/CMOS DC control pin for parallel mode operation
12	NC_GND	No connection. Can be grounded without affecting performance.	24	D0	TTL/CMOS DC control pin for parallel mode operation. D0 is LSB.

Functional Description

The SKY12347-362LF is a six bit digital attenuator comprised of a GaAs attenuator and a silicon CMOS driver. The attenuation setting is controlled by an SPI. Attenuation is set by a stream of data that is clocked into the shift registers of the silicon chip by the clock signal. To set the attenuation state, a latch signal is sent to the appropriate pin to send the correct bias voltages to the GaAs attenuator.

More than one attenuator can be cascaded together and the data may be passed through one device to the other using the SDO signal (pin 15). The DC bias voltage to the silicon CMOS chip is applied to pin 18 (VDD).

Power-Up/Power-Down Timing

Serial input data (SDI pin) is shifted into the register on the rising edge of the clock (CLK pin), Least Significant Bit (LSB) first. The attenuator changes states on the rising edge of the latch enable (LE pin) signal, according to the most recent six bits of shifted data accepted since the previous falling edge of the latch enable signal. The serial data output is the serial input data delayed by six clock cycles.

Refer to the timing diagram in Figure 3 and timing parameter specifications in Table 2. Table 3 shows the transition states based on the LE and CLK signals.

Power-up sequence is as follows:

0. Connect ground
1. Apply V_{DD}
2. Set all inputs (CLK, SDI, LE)

The power-down sequence is the reverse of above.

Figure 4 shows an example of how to set the attenuator to the 0.5 dB state. The progression of the bit states vs the clock signal is shown. The timing diagram shows that when the latch enable signal goes high, the voltages D0 to D5 set the attenuator to the 0.5 dB state.

Electrical and Mechanical Specifications

The absolute maximum ratings of the SKY12347-362LF are provided in Table 4. Electrical specifications are provided in Tables 5 and 6.

Typical performance characteristics of the SKY12347-362LF are illustrated in Figures 5 through 11.

The state of the SKY12347-362LF is determined by the logic provided in Table 7.

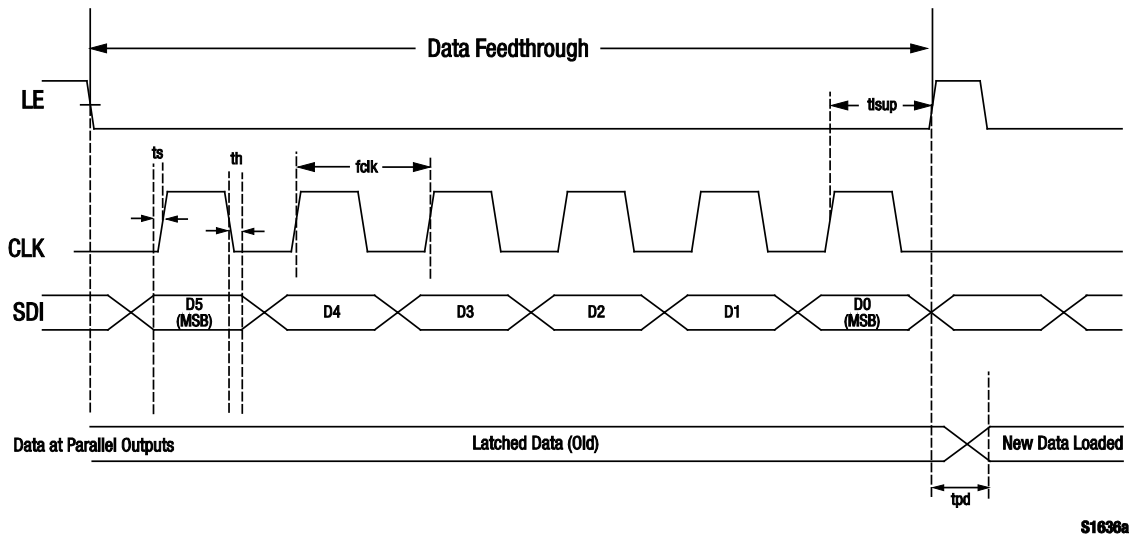

Figure 3. Power-Up/Power-Down Timing

Table 2. Power-Up/Power-Down Timing Parameters

Parameter	Symbol	VDD = 5 V			VDD = 3.3 V			Units
		Minimum	Typical	Maximum	Minimum	Typical	Maximum	
Serial input setup time	ts		5			5		ns
Hold time from serial input to shift clock	th		5			5		ns
Setup time from shift clock to latch enable	tlsup	40			100			ns
Propagation delay, latch enable to C0.5 through C8	tpd			30			70	ns
Setup time from reset to shift clock	–	20			50			ns
Clock frequency	fCLK			30			10	MHz

Table 3. Transition State Logic

LE (Pin 4)	CLK (Pin 2)	Function
X	→	Shift register clocked
→	X	Contents of shift register transferred to digital attenuator

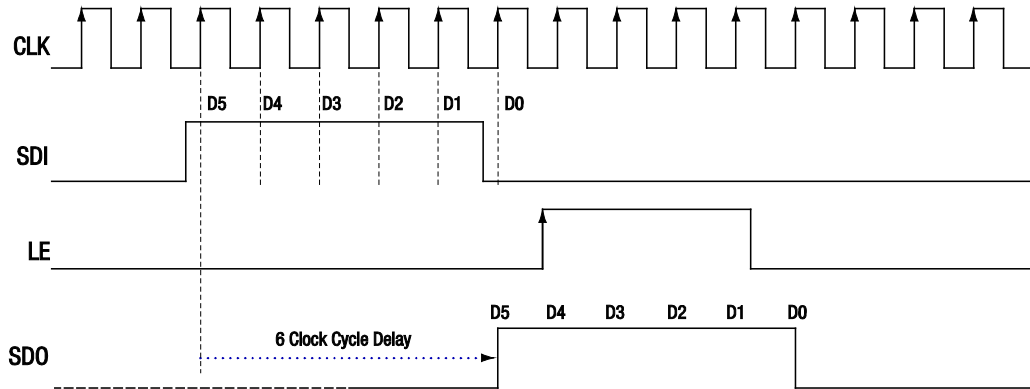

S2155

Figure 4. Example for Setting 0.5 dB State

Table 4. SKY12347-362LF Absolute Maximum Ratings

Parameter	Symbol	Minimum	Maximum	Units
Supply voltage	V _{DD}	3.3	6.0	V
Control voltage	V _{CTL}	0	V _{DD}	V
RF input power	P _{IN}		+30	dBm
Operating temperature	T _{OP}	-40	+85	°C
Storage temperature	T _{STG}	-40	+125	°C

Note: Exposure to maximum rating conditions for extended periods may reduce device reliability. There is no damage to device with only one parameter set at the limit and all other parameters set at or below their nominal value. Exceeding any of the limits listed here may result in permanent damage to the device.

CAUTION: Although this device is designed to be as robust as possible, Electrostatic Discharge (ESD) can damage this device. This device must be protected at all times from ESD. Static charges may easily produce potentials of several kilovolts on the human body or equipment, which can discharge without detection. Industry-standard ESD precautions should be used at all times.

Table 5. SKY12347-362LF Electrical Specifications (Note 1) (1 of 2)

(V_{DD} = 5 V, V_{CTL} = 5 V, T_{OP} = +25 °C, P_{IN} = 0 dBm, Characteristic Impedance [Z₀] = 50 Ω, , Unless Otherwise Noted)

Parameter	Symbol	Test Condition	Min	Typical	Max	Units
RF Specifications						
Insertion loss	IL	DC to 0.8 GHz		1.2	1.3	dB
		0.8 to 3.0 GHz		2.0	2.2	dB
Attenuation range		DC to 3.0 GHz	0.5		31.5	dB
Return loss	RL	DC to 3.0 GHz		15		dB
Attenuation accuracy		All attenuation states				
		DC to 0.8 GHz 0.8 to 3.0 GHz	±(0.1 + 5% of attenuation setting max) ±(0.3 + 3% of attenuation setting max)			dB dB
0.1 dB Input Compression Point	IPO.1dB	DC to 3.0 GHz		+30		dBm
3 rd Order Input Intercept Point	IIP3	DC to 3.0 GHz, P _{IN} = +10 dBm/tone, ΔF = 1 MHz		+50		dBm
DC Specifications						
Control voltage: Low High	V _{CTL}		0 3.0		0.8 V _{DD}	V V
Supply voltage	V _{DD}		3.3	5.0	5.5	V
Supply current	I _{DD}			100		μA

Table 5. SKY12347-362LF Electrical Specifications (Note 1) (2 of 2)

($V_{DD} = 5\text{ V}$, $V_{CTL} = 5\text{ V}$, $T_{OP} = +25\text{ }^{\circ}\text{C}$, $P_{IN} = 0\text{ dBm}$, Characteristic Impedance [Z_0] = $50\text{ }\Omega$, , Unless Otherwise Noted)

Parameter	Symbol	Test Condition	Min	Typical	Max	Units
Switching Speed Specifications						
50% control to 90% attenuation		$V_{DD} = 3.3\text{ V}$, Bit = 3.3 V		91		ns
		$V_{DD} = 5.0\text{ V}$, Bit = 3.3 V		48		ns
		$V_{DD} = 5.0\text{ V}$, Bit = 5.0 V		47		ns
50% control to 10% attenuation		$V_{DD} = 3.3\text{ V}$, Bit = 3.3 V		19		ns
		$V_{DD} = 5.0\text{ V}$, Bit = 3.3 V		28		ns
		$V_{DD} = 5.0\text{ V}$, Bit = 5.0 V		28		ns
10% to 90% attenuation		$V_{DD} = 3.3\text{ V}$, Bit = 3.3 V		47		ns
		$V_{DD} = 5.0\text{ V}$, Bit = 3.3 V		24		ns
		$V_{DD} = 5.0\text{ V}$, Bit = 5.0 V		26		ns
90% to 10% attenuation		$V_{DD} = 3.3\text{ V}$, Bit = 3.3 V		35		ns
		$V_{DD} = 5.0\text{ V}$, Bit = 3.3 V		18		ns
		$V_{DD} = 5.0\text{ V}$, Bit = 5.0 V		18		ns

Note 1: Performance is guaranteed only under the conditions listed in this Table.

Typical Performance Characteristics

($V_{DD} = 5\text{ V}$, $V_{CTL} = 5\text{ V}$, $T_{OP} = +25\text{ }^{\circ}\text{C}$, $P_{IN} = 0\text{ dBm}$, Characteristic Impedance [Z_0] = $50\text{ }\Omega$, , Unless Otherwise Noted)

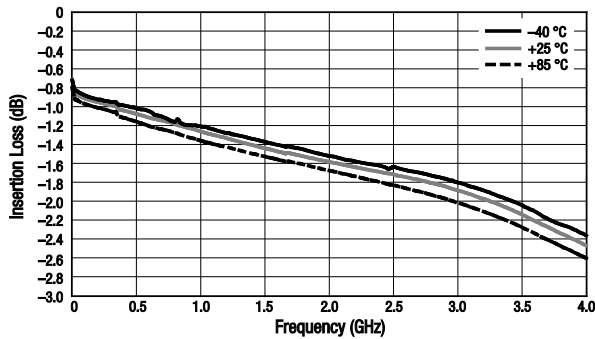

Figure 5. Insertion Loss vs Frequency

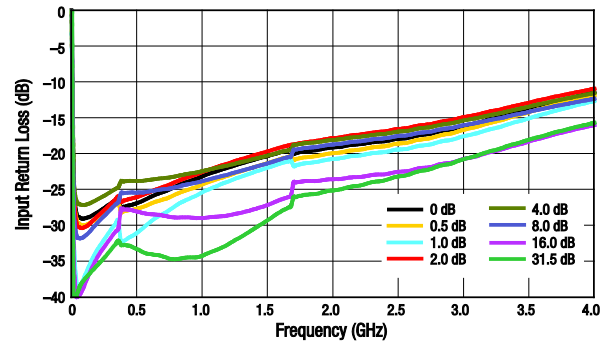

Figure 6. Input Return Loss vs Frequency

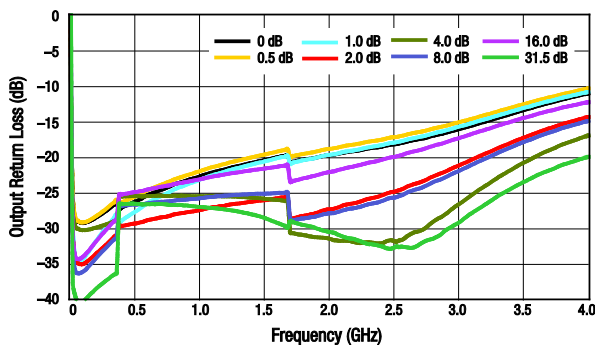

Figure 7. Output Return Loss vs Frequency

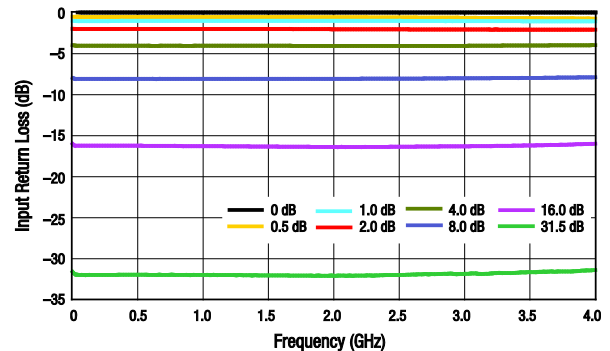

Figure 8. Normalized Attenuation vs Frequency

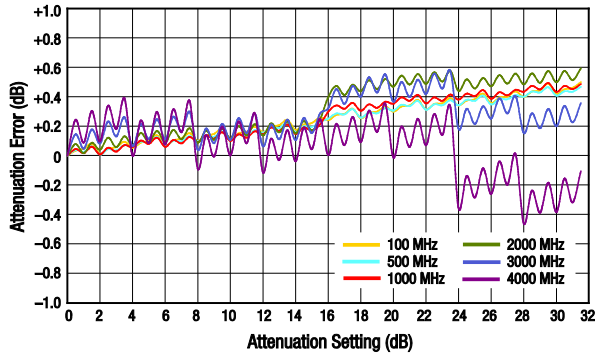

Figure 9. Attenuation Error vs Attenuation Setting

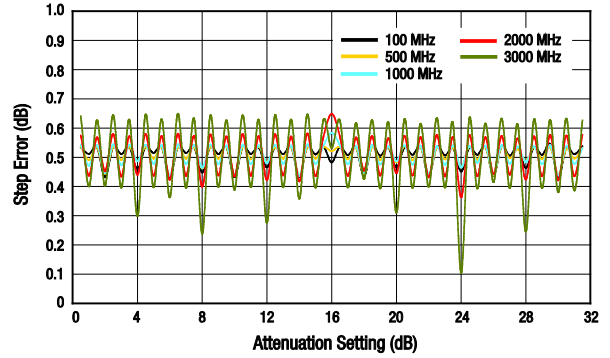

Figure 10. Step Error vs Attenuation Setting

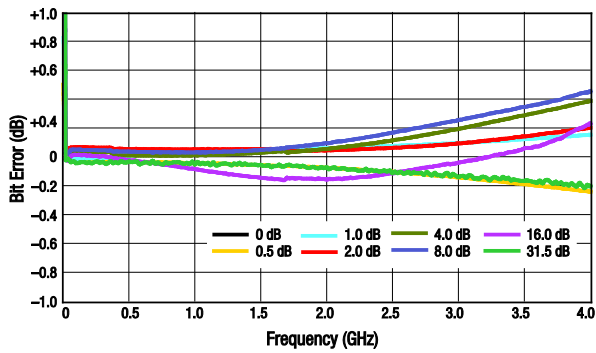

Figure 11. Major State Bit Error vs Frequency

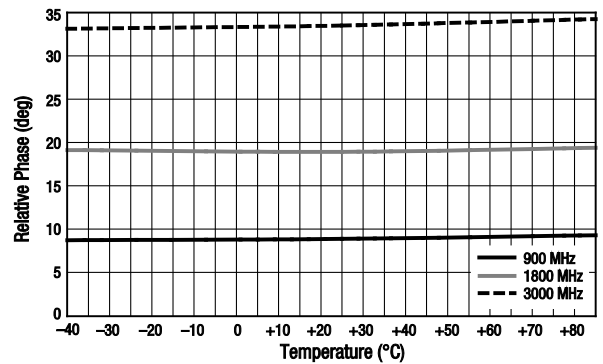

Figure 12. 31.5 dB State Relative Phase vs Temperature

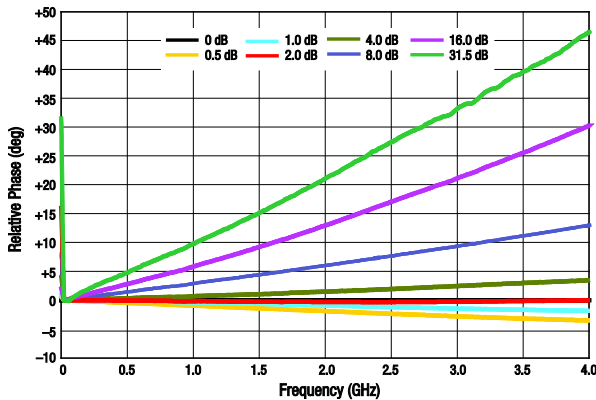

Figure 13. Relative Phase vs Frequency

Table 6. SKY12347-362LF Parallel Mode Truth Table

RF1/RF2 (Pins 6 & 13) Attenuation	D5 (Pin 19)	D4 (Pin 20)	D3 (Pin 21)	D2 (Pin 22)	D1 (Pin 23)	D0 (Pin 24)
Insertion loss	1	1	1	1	1	1
0.5 dB	1	1	1	1	1	0
1.0 dB	1	1	1	1	0	1
2.0 dB	1	1	1	0	1	1
4.0 dB	1	1	0	1	1	1
8.0 dB	1	0	1	1	1	1
16 dB	0	1	1	1	1	1
31.5 dB	0	0	0	0	0	0

Note: "1" = high control voltage: +3.0 to V_{DD}.
 "0" = low control voltage: 0 to +0.8 V.

Table 7. SKY12347-362LF Power-Up Truth Table

Initial Attenuation State	LE (Pin 4)	PUP1 (Pin 17)	PUP2 (Pin 16)
31.5 dB	0	0	0
24.0 dB	0	1	0
16.0 dB	0	0	1
Insertion Loss	0	1	1
State is determined by signal logic at pins D0 to D5. See Table 6.	1	X	X

Note: "1" = Logic high
 "0" = Logic low
 "X" = don't care

Evaluation Board Description

The SKY12347-362LF Evaluation Board is used to test the performance of the SKY12347-362LF digital attenuator. An assembly drawing for the Evaluation Board is shown in Figure 14 and an Evaluation Board schematic diagram is shown in Figure 15.

Package Dimensions

The PCB layout footprint for the SKY12347-362LF is shown in Figure 16. Typical case markings are noted in Figure 17. Package dimensions for the 24-pin QFN are shown in Figure 18, and tape and reel dimensions are provided in Figure 19.

Package and Handling Information

Instructions on the shipping container label regarding exposure to moisture after the container seal is broken must be followed. Otherwise, problems related to moisture absorption may occur when the part is subjected to high temperature during solder assembly.

THE SKY12347-362LF is rated to Moisture Sensitivity Level 1 (MSL1) at 260 °C. It can be used for lead or lead-free soldering. For additional information, refer to the Skyworks Application Note, *Solder Reflow Information*, document number 200164.

Care must be taken when attaching this product, whether it is done manually or in a production solder reflow environment. Production quantities of this product are shipped in a standard tape and reel format.

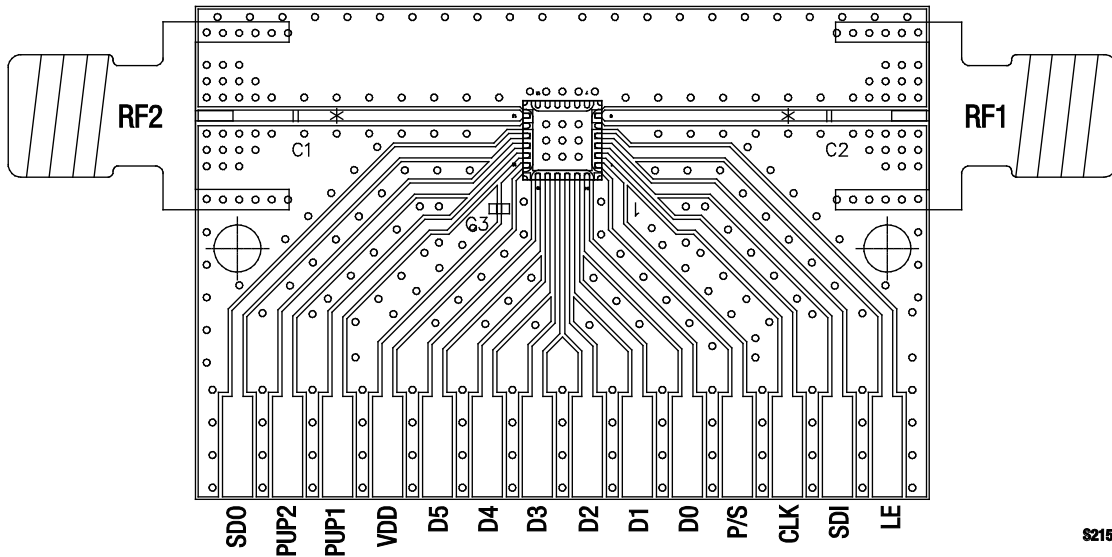

S2152

Figure 14. SKY12347-362LF Evaluation Board Assembly Diagram

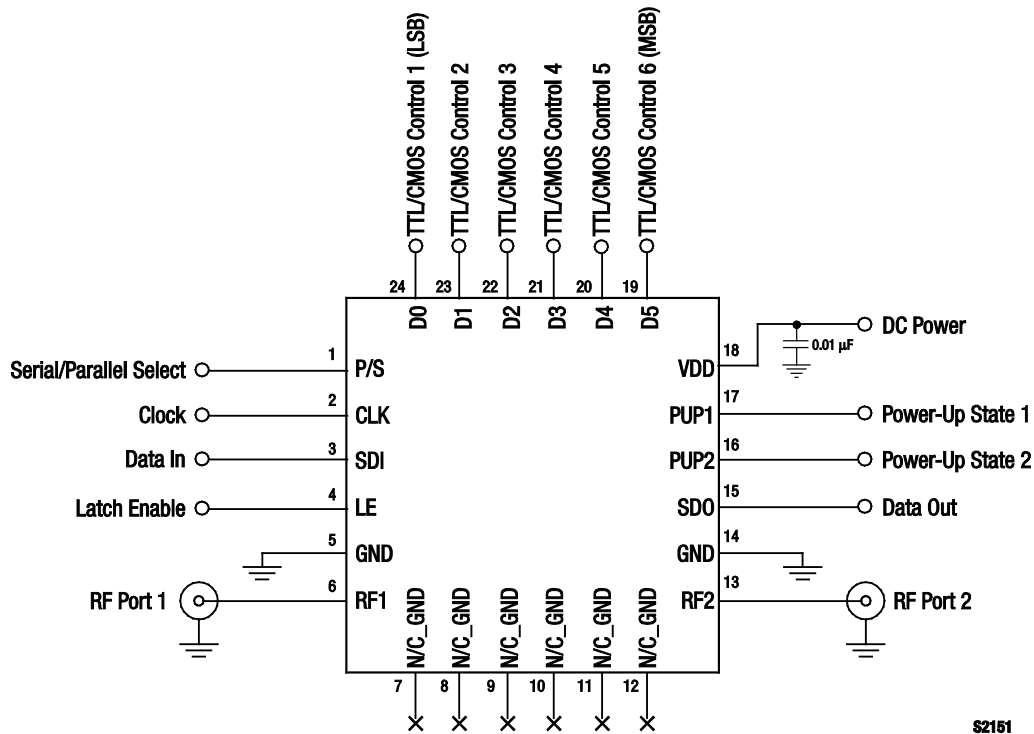

S2151

Figure 15. SKY12347-362LF Evaluation Board Schematic Diagram

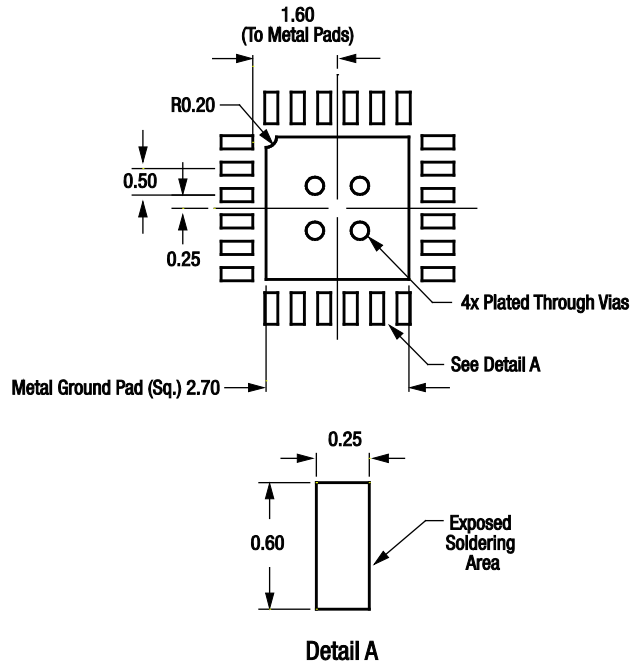

All dimensions are in millimeters

S1637

Figure 16. SKY12347-362LF PCB Layout Footprint

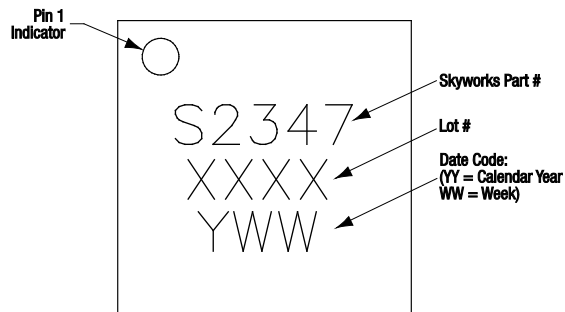
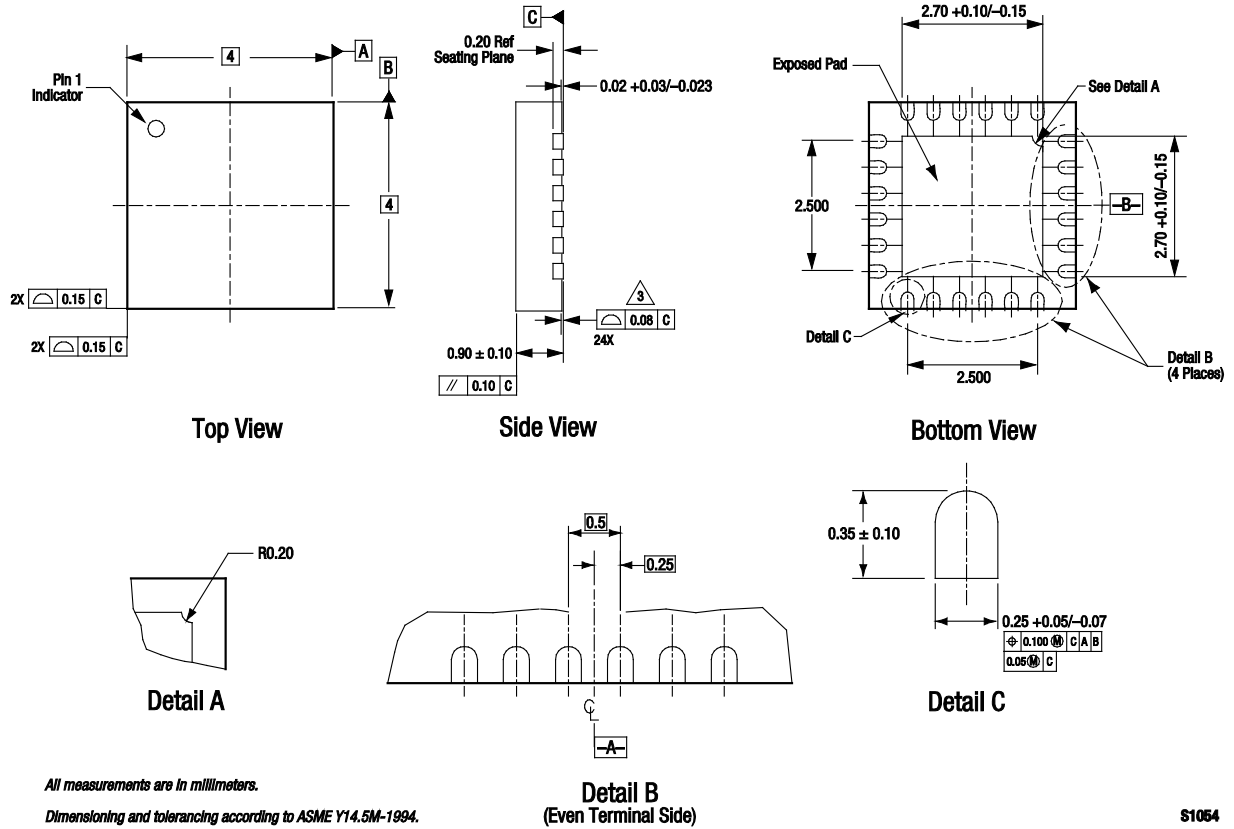
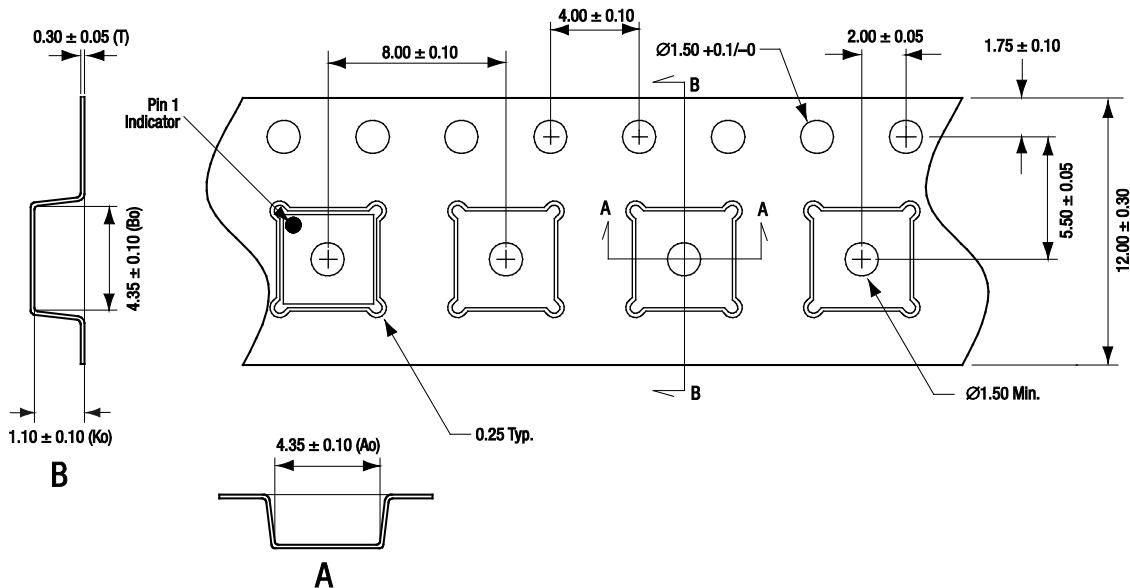

Figure 17. Typical Part Markings



S1064

Figure 18. SKY12347-362LF 24-Pin QFN Package Dimensions



- Notes:**
- Carrier tape material: black conductive polystyrene, non-bakeable
 - Cover tape material: transparent conductive HSA
 - Cover tape size: 9.2 mm width
 - All measurements are in millimeters

S1846

Figure 19. SKY12347-362LF Tape and Reel Dimensions

Ordering Information

Model Name	Manufacturing Part Number	Evaluation Board Part Numbers
SKY12347-362LF Digital Attenuator	SKY12347-362LF	SKY12347-362LF-EVB

Copyright © 2011 Skyworks Solutions, Inc. All Rights Reserved.

Information in this document is provided in connection with Skyworks Solutions, Inc. ("Skyworks") products or services. These materials, including the information contained herein, are provided by Skyworks as a service to its customers and may be used for informational purposes only by the customer. Skyworks assumes no responsibility for errors or omissions in these materials or the information contained herein. Skyworks may change its documentation, products, services, specifications or product descriptions at any time, without notice. Skyworks makes no commitment to update the materials or information and shall have no responsibility whatsoever for conflicts, incompatibilities, or other difficulties arising from any future changes.

No license, whether express, implied, by estoppel or otherwise, is granted to any intellectual property rights by this document. Skyworks assumes no liability for any materials, products or information provided hereunder, including the sale, distribution, reproduction or use of Skyworks products, information or materials, except as may be provided in Skyworks Terms and Conditions of Sale.

THE MATERIALS, PRODUCTS AND INFORMATION ARE PROVIDED "AS IS" WITHOUT WARRANTY OF ANY KIND, WHETHER EXPRESS, IMPLIED, STATUTORY, OR OTHERWISE, INCLUDING FITNESS FOR A PARTICULAR PURPOSE OR USE, MERCHANTABILITY, PERFORMANCE, QUALITY OR NON-INFRINGEMENT OF ANY INTELLECTUAL PROPERTY RIGHT; ALL SUCH WARRANTIES ARE HEREBY EXPRESSLY DISCLAIMED. SKYWORKS DOES NOT WARRANT THE ACCURACY OR COMPLETENESS OF THE INFORMATION, TEXT, GRAPHICS OR OTHER ITEMS CONTAINED WITHIN THESE MATERIALS. SKYWORKS SHALL NOT BE LIABLE FOR ANY DAMAGES, INCLUDING BUT NOT LIMITED TO ANY SPECIAL, INDIRECT, INCIDENTAL, STATUTORY, OR CONSEQUENTIAL DAMAGES, INCLUDING WITHOUT LIMITATION, LOST REVENUES OR LOST PROFITS THAT MAY RESULT FROM THE USE OF THE MATERIALS OR INFORMATION, WHETHER OR NOT THE RECIPIENT OF MATERIALS HAS BEEN ADVISED OF THE POSSIBILITY OF SUCH DAMAGE.

Skyworks products are not intended for use in medical, lifesaving or life-sustaining applications, or other equipment in which the failure of the Skyworks products could lead to personal injury, death, physical or environmental damage. Skyworks customers using or selling Skyworks products for use in such applications do so at their own risk and agree to fully indemnify Skyworks for any damages resulting from such improper use or sale.

Customers are responsible for their products and applications using Skyworks products, which may deviate from published specifications as a result of design defects, errors, or operation of products outside of published parameters or design specifications. Customers should include design and operating safeguards to minimize these and other risks. Skyworks assumes no liability for applications assistance, customer product design, or damage to any equipment resulting from the use of Skyworks products outside of stated published specifications or parameters.

Skyworks, the Skyworks symbol, and "Breakthrough Simplicity" are trademarks or registered trademarks of Skyworks Solutions, Inc., in the United States and other countries. Third-party brands and names are for identification purposes only, and are the property of their respective owners. Additional information, including relevant terms and conditions, posted at www.skyworksinc.com, are incorporated by reference.