

ROTARY SELECTOR SWITCHES (SMD)

CS-32

RoHS compliant

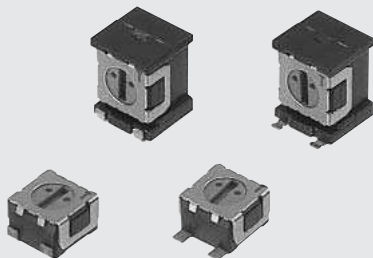

FEATURES

- RoHS compliant
- Optimum for high density board mounting applications
- Compatible with most automatic pick & place machinery
- Protection against dust and washable after soldering
- Top and side setting types are available
- Same dimensions as ST-32 trimmer and conveniently usable as a set

INTERNAL STRUCTURE

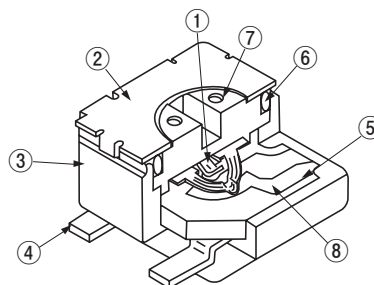

Part name	Material	Flammability
① Wiper	Multi metal alloy	—
② Cover	Stainless steel (SUS 304)	
③ Housing	Epoxy	UL-94V-0
④ Terminal pin	Copper alloy, Sn-Cu-plated	—
⑤ Base element	Ceramic	
⑥ "O" ring	Silicone rubber	UL-94HB
⑦ Rotor	PPS(Polyphenylenesulphide)	UL-94V-0
⑧ Electrode	Ag-Pd cermet	—

PART NUMBER DESIGNATION

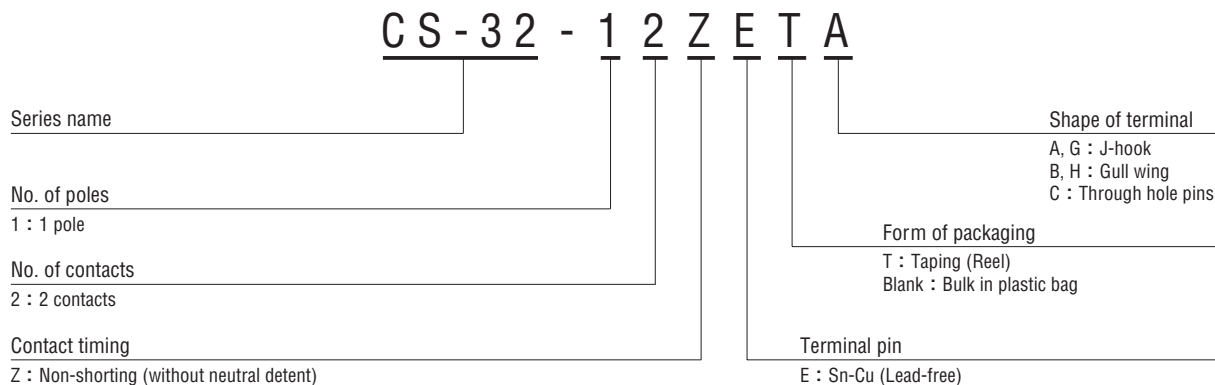

※ Please refer to the LIST OF PART NUMBERS when placing orders.

CS-32 ROTARY SELECTOR SWITCHES (SMD)

SCHEMATICS DIAGRAMS

● 1 pole 2 contacts

Series	Switching specifications	Schematic
CS-32-12ZEA ⤵ 12ZEB ⤵ 12ZEC ⤵ 12ZEG ⤵ 12ZEH		

LIST OF PART NUMBERS

Circuit type		Setting position	Form of packaging	J-hook A, G	Gull wing B, H	Through hole pins C	Pieces in package
1 pole 2 contacts	Whitout neutral detent	Top setting	Taping	CS-32-12ZETA	CS-32-12ZETB		500 pcs. /reel
			Plastic bag	CS-32-12ZEA	CS-32-12ZEB	CS-32-12ZEC	100 pcs. /pack
		Side setting	Taping	CS-32-12ZETG	CS-32-12ZETH		500 pcs. /reel
			Plastic bag	CS-32-12ZEG	CS-32-12ZEH		100 pcs. /pack

※ Verify the above part numbers when placing orders.
 Taping version can be supplied only in reel unit.

CS-32

ROTARY SELECTOR SWITCHES (SMD)

STANDARD SPECIFICATIONS

Circuit type	1 pole 2 contacts
Operating temperature range	-40 ~ 85 °C
Storage temperature range	
Sealing	Washable by "O" ring
Net weight	Approx. 0.05g (A, B) Approx. 0.06g (C) Approx. 0.11g (G, H)

ELECTRICAL CHARACTERISTICS

Contact rating	0.5 VA
Maximum current	100 mA
Maximum voltage	16 V
Contact timing	Non-shorting
Contact resistance	2 Ω maximum
Insulation resistance	100 MΩ (DC500 V) minimum
Dielectric strength	AC250 V, 60 s

MECHANICAL CHARACTERISTICS

No. of positions	2
Adjustment torque	5 mN·m {51 gf·cm} maximum
Stopper strength	20 mN·m {204 gf·cm} minimum
Stepping angle	250° ± 15°
Solderability	Sn-Cu (lead-free): 245 ± 3 °C, 2 ~ 3 s
Soldering heat	Sn-Cu (Lead-free) Flow : 260 ± 3 °C as the temperature in a pot of molten solder, immersion from head of terminal to backside of board, 5 ~ 6 s, two times maximum. Reflow : Peak temperature 255 °C (Please refer to the profile below.) Manual soldering : 350 ± 10 °C, 3 ~ 4 s
Shear (Adhesion)	5 N {0.51 kgf}, 10 s
Substrate bending	Width 90 mm, bend 3 mm, 5 s, 1 time
Pull-off strength	5 N {0.51 kgf}, 10 s

{ } : Reference only

ENVIRONMENTAL CHARACTERISTICS

Vibration	Amplitude 1.5 mm or Acceleration 98 m/s ² , 10-500-10 Hz, 3 directions for 3 times each
Shock	490 m/s ² , 11 ms 6 directions for 3 times each
Load life	50 cycles minimum DC16 V 30 mA
Humidity (Steady state)	40 °C, Relative humidity 90 ~ 95 %, 240 h
High temperature exposure	85 °C, 96 h
Low temperature exposure	-40 °C, 96 h
Thermal shock	-40 (0.5 h) ~ 85 °C (0.5 h), 5 cycles

<Reflow profile for soldering heat evaluation>

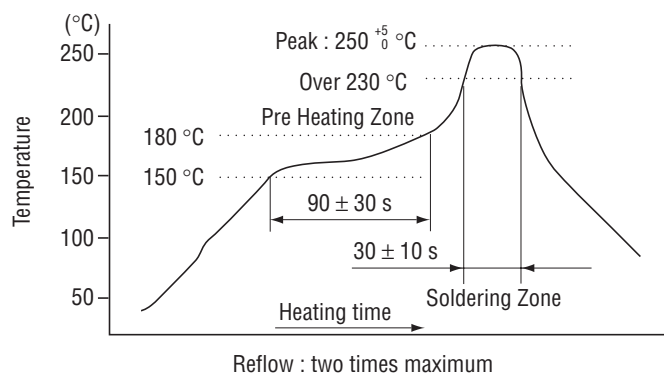

CS-32 ROTARY SELECTOR SWITCHES (SMD)

OUTLINE DIMENSIONS

Unless otherwise specified, tolerance: ± 0.3 (Unit: mm)

CS-32-12ZEA

Production date code &
 Lead-free Identification mark,
 1 digit (Location reversed every 2 years)

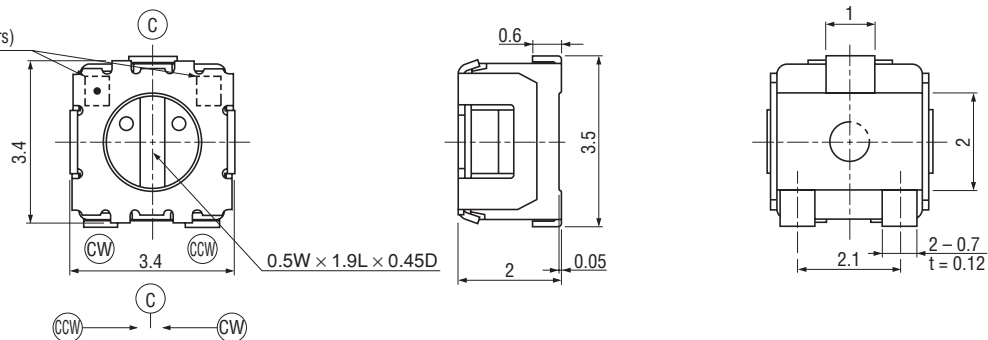

CS-32-12ZEB

Production date code &
 Lead-free Identification mark,
 1 digit (Location reversed every 2 years)

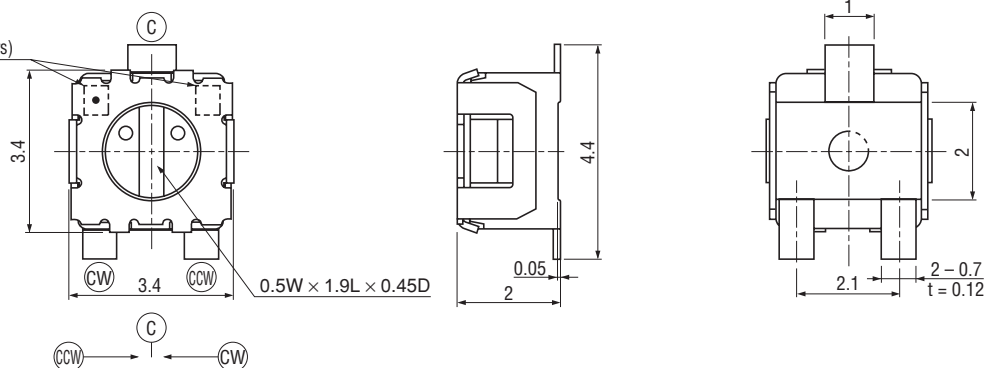

CS-32-12ZEC

Production date code &
 Lead-free Identification mark,
 1 digit (Location reversed every 2 years)

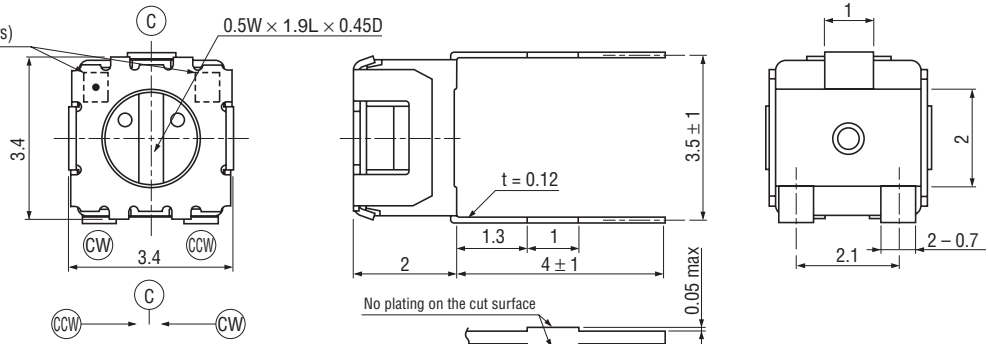

CS-32-12ZEG

Production date code &
 Lead-free Identification mark,
 1 digit (Location reversed every 2 years)

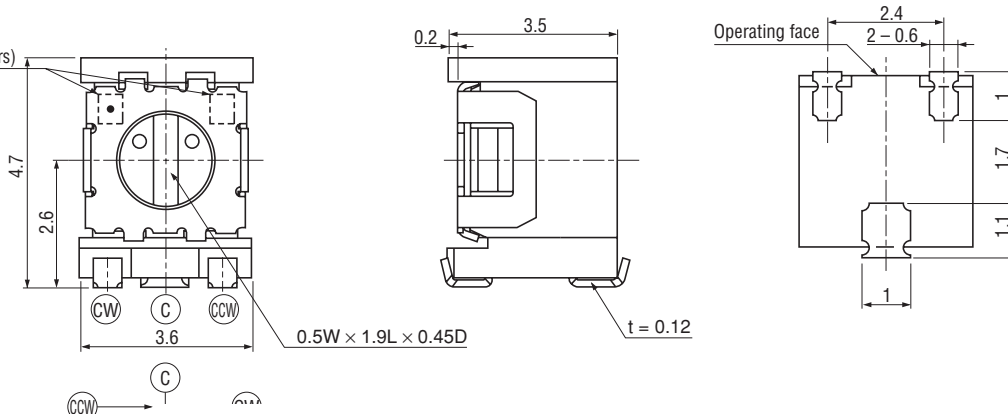

CS-32 ROTARY SELECTOR SWITCHES (SMD)

OUTLINE DIMENSIONS

CS-32-12ZEH

Production date code &
 Lead-free Identification mark,
 1 digit (Location reversed every 2 years)

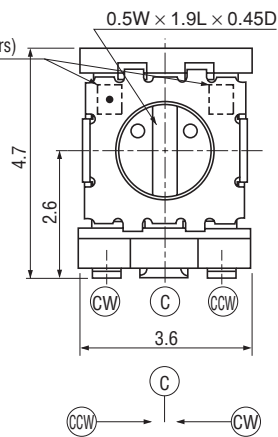

Unless otherwise specified, tolerance: ± 0.3 (Unit: mm)

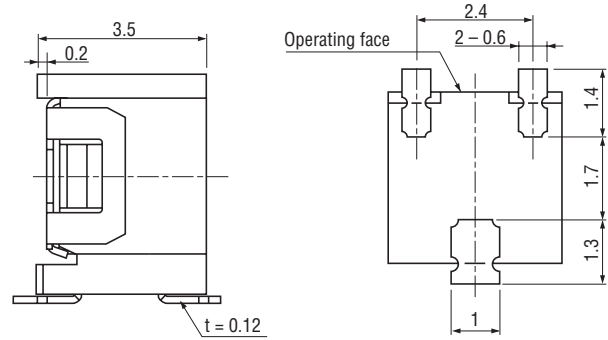

RECOMMENDED P.C.B. PAD OUTLINE DIMENSIONS

CS-32-12ZEA, 12ZEG

CS-32-12ZEB, 12ZEH

(Unit: mm)

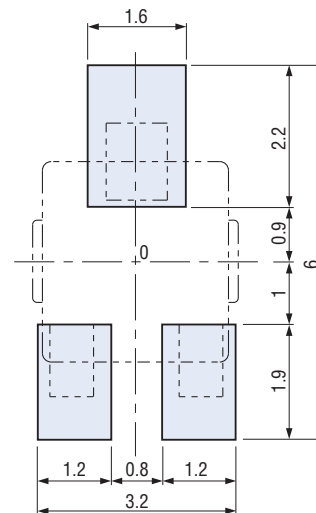
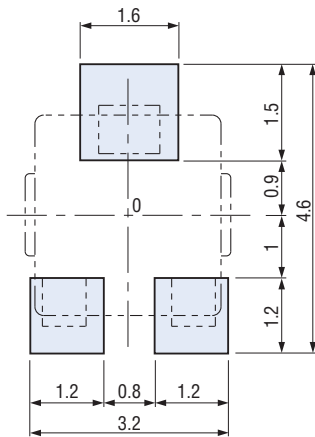

Note 1) The zero point is the center of mounting.
 Note 2) The land patterns conform to EIAJ RC2161.
 Note 3) The land patterns are for reflow soldering.

CS-32 ROTARY SELECTOR SWITCHES (SMD)

PACKAGING SPECIFICATIONS

<Taping packaging specifications>

- Taping version is packaged in 500 pcs. per reel.
 Orders will be accepted for units of 500 pcs., i.e., 500, 1000, 1500 pcs., etc.
- CS-32ZETA and ZETB versions are boxed with 4 reels (2000 pcs.). CS-32ZETG and ZETH versions are boxed with one reel (500 pcs.)

Maximum number of consecutive missing pieces = 2
 Leader length and reel dimension are shown in the dia-grams below:

● Embossed tape dimensions

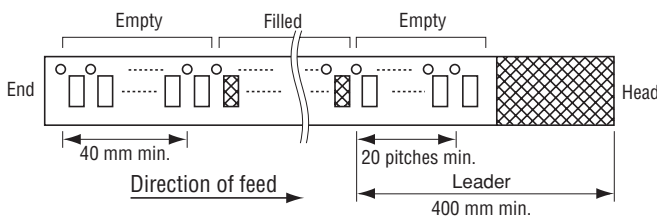

● Reel dimensions

(Unit: mm)
 (Conforms to JIS C 0806-3)
 (In accordance with EIAJ ET-7200A)

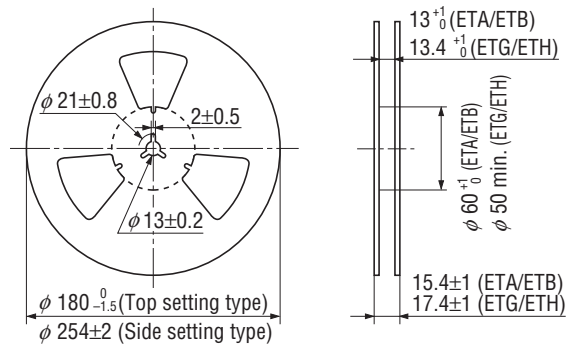

● CS-32-12ZETA/CS-32-12ZETB

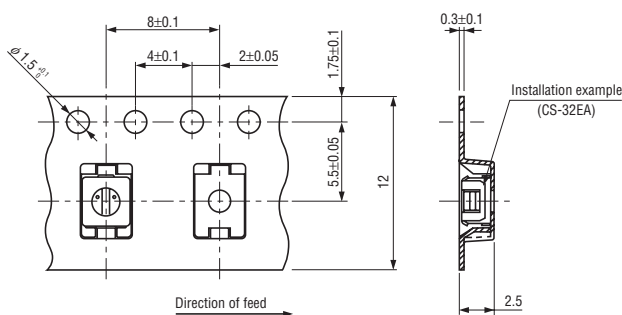

● CS-32-12ZETG/CS-32-12ZETH

(Unit: mm)
 (Conforms to JIS C 0806)

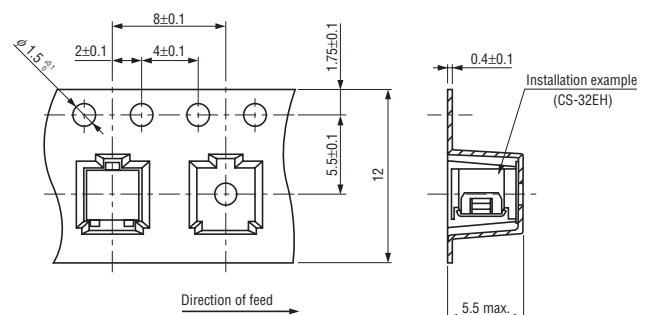

<Bulk pack specifications>

- The smallest unit of bulk pack in a plastic bag is 10 pcs. per pack. Orders will be accepted for unit of minimum 10 pcs., i.e., 10, 20, 30 pcs., etc.
- Boxing of bulk in a plastic bag is performed with 100 pcs. (standard 500 pcs.) per box.