

# HIGH Q CERAMIC WIRE WOUND INDUCTORS

AISC-0805HQ



RoHS/RoHS II Compliant



2.29 x 1.73 x 1.52mm

## FEATURES:

- Higher Q and lower DCR than other 0805 inductors
- Very high SRF – as high as 6 GHz
- Excellent current handling capability – up to 1600mA
- Wide range of Inductance values available for flexible needs
- Tight tolerance of 2% is available.

## APPLICATIONS:

- Widely used in communications applications such as cell phones, cable modems, ADSL, repeaters.
- Bluetooth, W-LAN, GPS, Broadband Network
- Video cameras, liquid crystal television, and other electronic devices
- Suitable for RF circuit

## ELECTRICAL SPECIFICATIONS:

### PARAMETERS

ABRACON P/N:	AISC-0805HQ
Operating temperature:	-40°C to + 125°C in Tape & Reel
Storage temperature in Tape and Reel:	+22°C to +28°C, 80% RH max.

Part Number AISC-0805HQ- Inductance Code	Inductance	Tolerance	Min. Quality Factor	L/Q Test Freq.	Max. DC Resistance	Max. Rated Current	Min. Self- resonant Frequency	Color Code
Units	nH	-	-	MHz	$\Omega$	mA	GHz	
Symbol	L	-	Q	Freq.	DCR	I <sub>r</sub>	S.R.F	
AISC-0805HQ-2N5	2.5	J, K	80	250/1500	0.020	1600	6.00	None
AISC-0805HQ-5N6	5.6	J, K	98	250/1500	0.035	1600	6.00	Brown
AISC-0805HQ-6N2	6.2	J, K	88	250/1000	0.035	1600	4.75	Red
AISC-0805HQ-6N8	6.8	J, K	80	250/1000	0.035	1600	4.40	White
AISC-0805HQ-8N2	8.2	J, K	75	250/1000	0.075	1000	3.00	Gray
AISC-0805HQ-10N	10	J, K	80	250/1000	0.060	1600	3.00	None
AISC-0805HQ-12N	12	J, K	80	250/1000	0.045	1600	3.00	Orange
AISC-0805HQ-15N	15	G, J, K	80	250/1000	0.100	1200	2.80	None
AISC-0805HQ-16N	16	G, J, K	72	250/500	0.060	1500	2.95	Yellow
AISC-0805HQ-18N	18	G, J, K	75	250/500	0.060	1400	2.55	Green
AISC-0805HQ-20N	20	G, J, K	70	250/500	0.055	1400	2.05	Blue
AISC-0805HQ-22N	22	G, J, K	80	250/500	0.100	1200	2.00	None
AISC-0805HQ-27N	27	G, J, K	75	250/500	0.070	1300	2.00	Violet
AISC-0805HQ-30N	30	G, J, K	65	250/500	0.095	1200	1.95	Gray
AISC-0805HQ-39N	39	G, J, K	65	250/500	0.110	1100	1.60	White
AISC-0805HQ-48N	48	G, J, K	65	200/500	0.095	1200	1.40	None
AISC-0805HQ-51N	51	G, J, K	65	200/500	0.120	1000	1.40	Brown

## Test Conditions

1. Inductance, Q: HP4286
2. SRF: HP4287
3. RDC: Micro-Ohm meter (Gom-801G)
4. Definition of Rated Current (I<sub>r</sub>): The current applied to inductor such that the inductance change should be less than 10% to initial value.

ABRACON IS  
ISO 9001:2008  
CERTIFIED

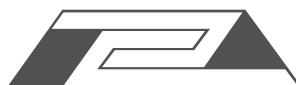

**ABRACON**  
CORPORATION

Visit [www.abracon.com](http://www.abracon.com) for Terms & Conditions of Sale  
30332 Esperanza, Rancho Santa Margarita, California 92688  
tel 949-546-8000 | fax 949-546-8001 | [www.abracon.com](http://www.abracon.com)

Revised: 05.28.13

# HIGH Q CERAMIC WIRE WOUND INDUCTORS

AISC-0805HQ



RoHS/RoHS II Compliant



2.29 x 1.73 x 1.52mm

## PART IDENTIFICATION:

AISC-0805HQ -   -

**Inductance Code**  
Please refer to the Table

**Tolerance Code**  
G: ±2%  
J: ±5%  
K: ±10%

**Packaging**  
T: 2kpcs/reel

## OUTLINE DIMENSIONS:

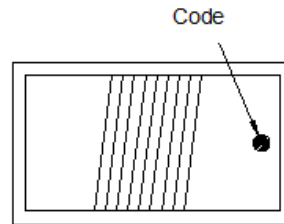
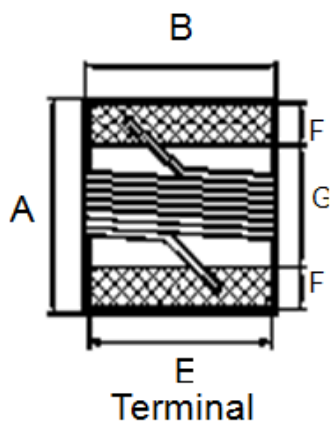

Recommended Land Pattern

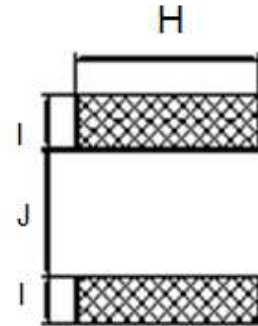

A max.	B max.	C max.	D Ref.	E	F	G	H	I	J
2.29	1.73	1.52	0.51	1.27	0.44	1.02	1.78	1.02	0.76

Dimension: mm

## MATERIALS

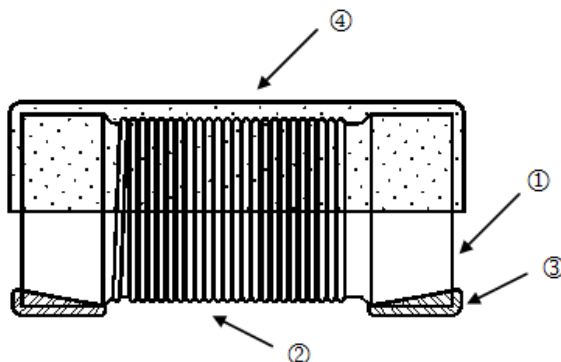

Components	Material
1	Ceramic Core
2	Magnet wire
3	Electrode (Ag/Pd+Ni+Sn)
4	UV Glue



# HIGH Q CERAMIC WIRE WOUND INDUCTORS

AISC-0805HQ

 RoHS/RoHS II Compliant



2.29 x 1.73 x 1.52mm

## REFLOW PROFILE

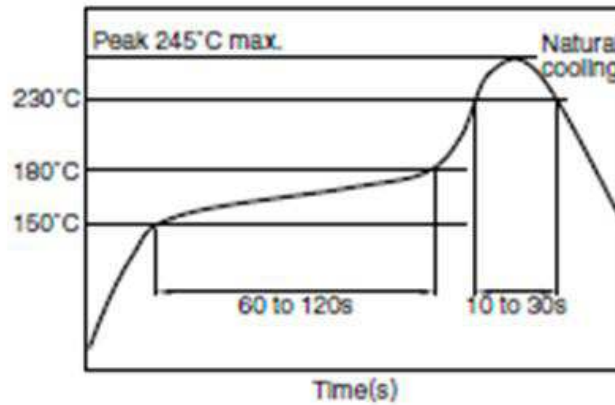

## TAPE & REEL:

T= tape and reel (2,000pcs/reel)

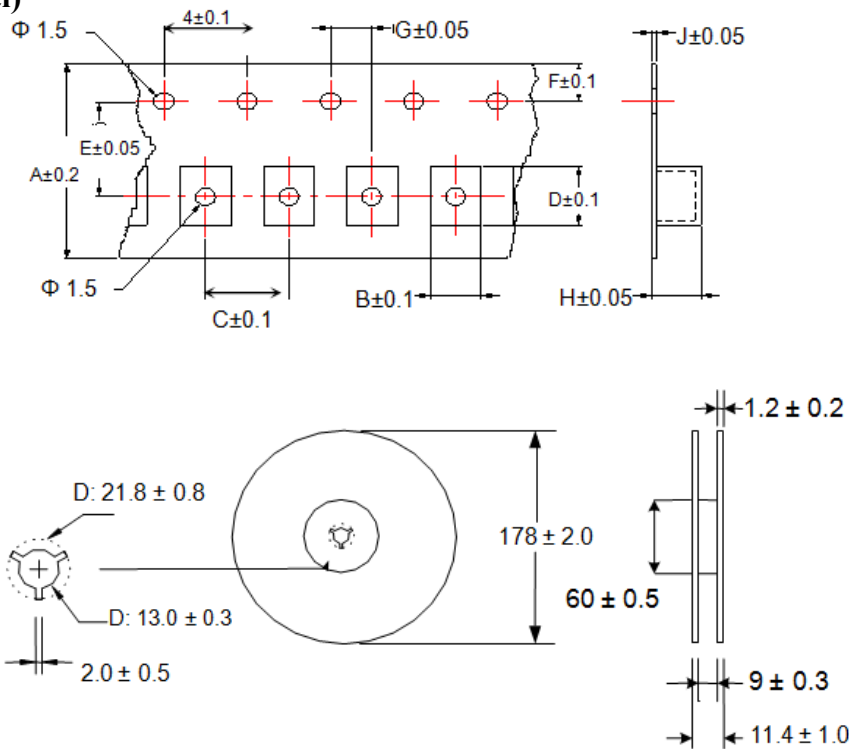

A	B	C	D	E	F	G	H	J
8	1.85	4	2.30	3.5	1.75	2	1.45	0.23

### Storage period

Use the product within 12 months after delivered. Solderability should be checked if this period is exceeded.

Dimension: mm

**ATTENTION:** Abracon Corporation's products are COTS – Commercial-Off-The-Shelf products; suitable for Commercial, Industrial and, where designated, Automotive Applications. Abracon's products are not specifically designed for Military, Aviation, Aerospace, Life-dependant Medical applications or any application requiring high reliability where component failure could result in loss of life and/or property. For applications requiring high reliability and/or presenting an extreme operating environment, written consent and authorization from Abracon Corporation is required. Please contact Abracon Corporation for more information.

ABRACON IS  
ISO 9001:2008  
CERTIFIED



Visit [www.abracon.com](http://www.abracon.com) for Terms & Conditions of Sale **Revised: 05.28.13**  
30332 Esperanza, Rancho Santa Margarita, California 92688  
tel 949-546-8000 | fax 949-546-8001 | [www.abracon.com](http://www.abracon.com)