

# HC49/U, HC51/U Crystal

AB



**RoHS**  
Compliant



11.5 x 5.0 x 13.46mm

## FEATURES:

- High precision availability
- Resistance welded
- Ideal for large pullability application
- Wide frequency range

## APPLICATIONS:

- CPU, Memory
- Computer, printer
- Data communication (1MHz)
- Data input - output machine (1MHz)

## STANDARD SPECIFICATIONS:

Parameters	Minimum	Typical	Maximum	Units	Notes
Frequency Range	1.8432		60.000	MHz	HC49/U
	0.850		1.800	MHz	HC51/U
Operation Mode	Fundamental				0.850MHz – 24.000MHz
	3 <sup>rd</sup> Overtone				24.01MHz – 66.00MHz
	5 <sup>th</sup> Overtone				66.01MHz – 122.00MHz
	7 <sup>th</sup> Overtone				122.01MHz – 160.00MHz
Operating Temperature	0		+70	°C	See options
Storage Temperature	-55		+125	°C	
Frequency Tolerance @+25°C	-50		+50	ppm	See options
Frequency Stability over the operating temperature ( ref. to +25°C)	-100		+100	ppm	See options
Equivalent series resistance (R1)	See table 1 below			Ω	
Shunt capacitance (C0)			7	pF	
Load capacitance (CL)		18		pF	See options
Drive Level		100	1000	μW	
Aging@25°C±3°C			±5	ppm	First year
Insulation Resistance	500			M Ω	@100Vdc±15V
Drive level dependency (DLD), minimum 7 points tested: from 1μW to 500μW.	Change in frequency (Maximum - Minimum) over DLD range < ±10ppm; Change in ESR (Maximum - Minimum) over DLD range < 25% of Max ESR value; Maximum ESR over DLD range < Max ESR value.				

**Table 1**

FREQUENCY (MHz)	Operation Mode	ESR (Ω) max	
1.000-1.799	HC49/U Fundamental	2000	
1.800-1.999		750	
2.000-2.399		550	
2.400-2.999		350	
3.000-3.699		200	
3.700-4.199		100	
4.200-4.899		70	
4.900-5.999		50	
6.000-7.999		40	
8.000-9.999		35	
10.000-12.499		30	
12.50-50.00		25	
24.00-66.00		HC49/U (3rd OT)	40
66.01-122.00		HC49/U (5th OT)	80
122.01-160.00	HC49/U (7th OT)	120	
0.850-0.899	HC51/U Fundamental	1000	
0.900-1.5		800	

ABRACON IS  
ISO 9001:2008  
CERTIFIED



Visit [www.abracon.com](http://www.abracon.com) for Terms & Conditions of Sale  
30332 Esperanza, Rancho Santa Margarita, California 92688  
tel 949-546-8000 | fax 949-546-8001 | [www.abracon.com](http://www.abracon.com)

Revised: 05.02.13

# HC49/U, HC51/U Crystal

AB



RoHS  
Compliant

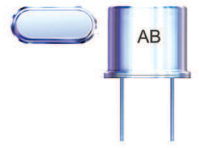

11.5 x 5.0 x 13.46mm

## OPTIONS AND PART IDENTIFICATION:

(Left blank if standard)

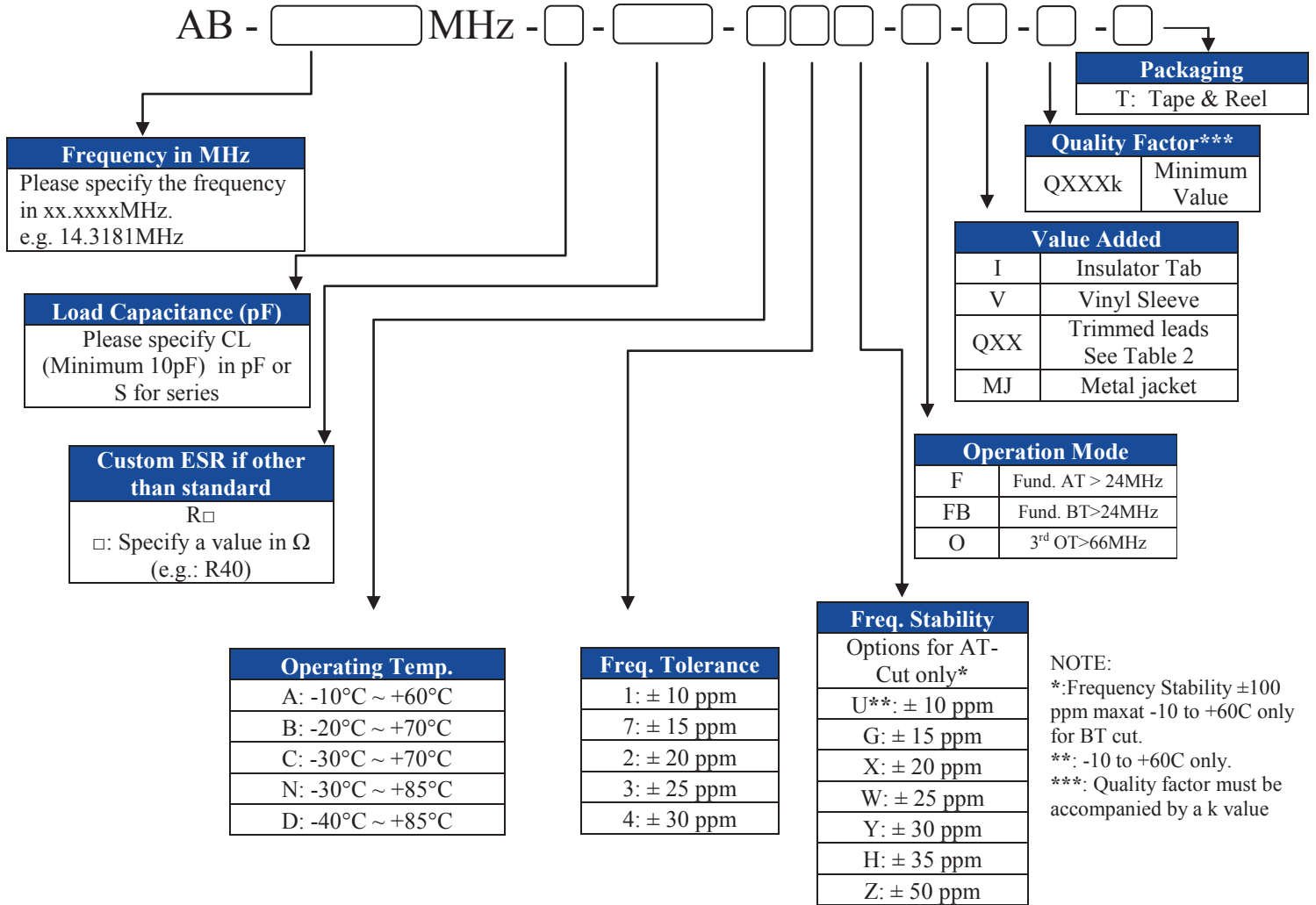

NOTE:  
\*: Frequency Stability ±100 ppm max at -10 to +60C only for BT cut.  
\*\*: -10 to +60C only.  
\*\*\*: Quality factor must be accompanied by a k value

Table 2

CODES	TRIMMED L in(mm)
Q45	0.45 (11.43)
Q40	0.40 (10.16)
Q35	0.35 (8.89)
Q30	0.30 (7.62)
Q25	0.25 (6.35)
Q20	0.20 (5.08)
Q15	0.15 (3.81)
Q10	0.10 (2.54)
Q115	0.115 (2.92)

NOTE: Use appropriate code numbers for other trimmed lengths not listed. (e.g. Q14 for 0.14 inch (3.55 mm))

# HC49/U, HC51/U Crystal

AB



RoHS  
Compliant



11.5 x 5.0 x 13.46mm

## OUTLINE DRAWING:

### HC49U:

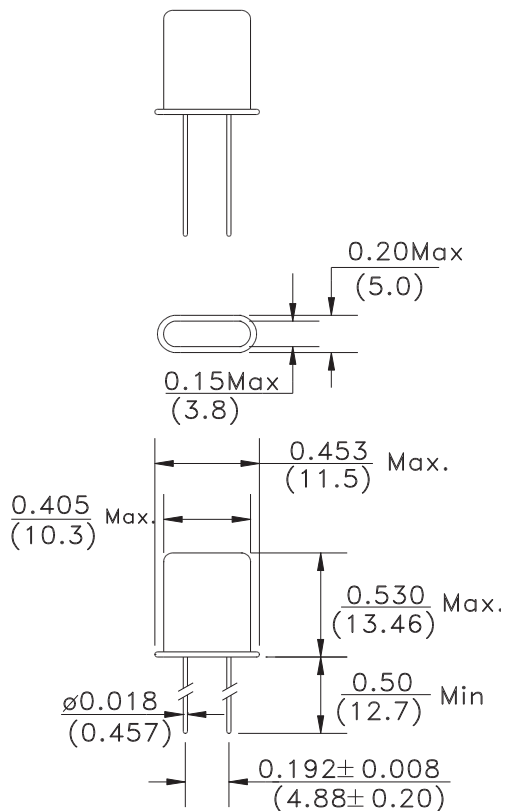

### HC51U:

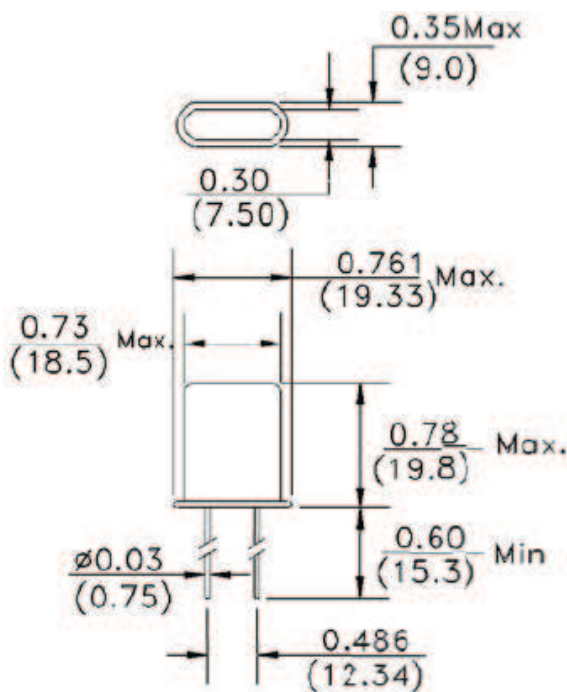

Dimensions: inch (mm)

ABRACON IS  
ISO 9001:2008  
CERTIFIED



**ABRACON**  
CORPORATION

Visit [www.abracon.com](http://www.abracon.com) for Terms & Conditions of Sale  
30332 Esperanza, Rancho Santa Margarita, California 92688  
tel 949-546-8000 | fax 949-546-8001 | [www.abracon.com](http://www.abracon.com)

Revised: 05.02.13

# HC49/U, HC51/U Crystal

AB



RoHS  
Compliant

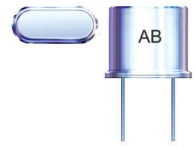

11.5 x 5.0 x 13.46mm

## REFLOW PROFILE:

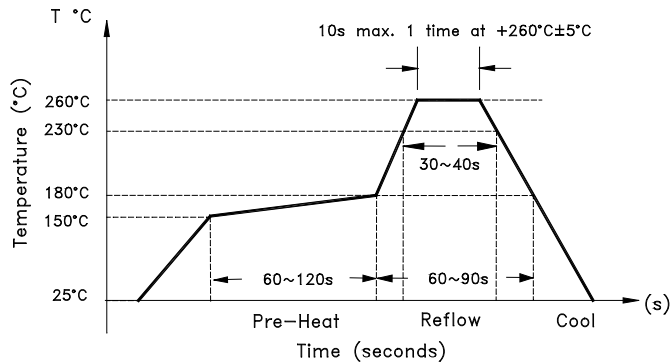

## TAPE & REEL: T 1,000 pcs/reel

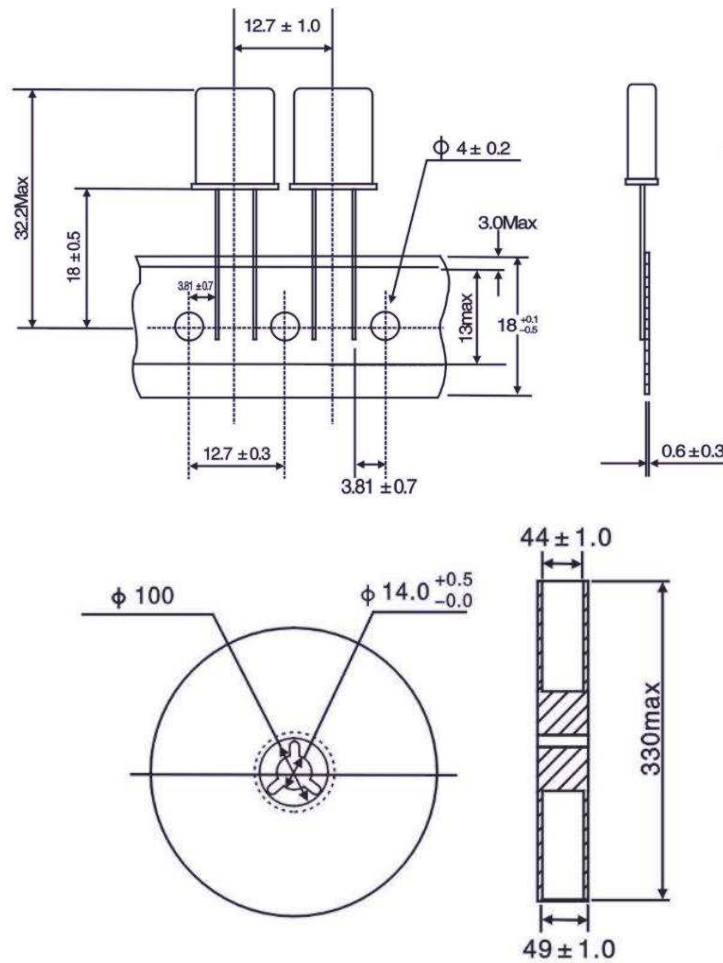

Dimensions: mm

**ATTENTION:** Abracon Corporation's products are COTS – Commercial-Off-The-Shelf products; suitable for Commercial, Industrial and, where designated, Automotive Applications. Abracon's products are not specifically designed for Military, Aviation, Aerospace, Life-dependant Medical applications or any application requiring high reliability where component failure could result in loss of life and/or property. For applications requiring high reliability and/or presenting an extreme operating environment, written consent and authorization from Abracon Corporation is required. Please contact Abracon Corporation for more information.

ABRACON IS  
ISO 9001:2008  
CERTIFIED



Visit [www.abracon.com](http://www.abracon.com) for Terms & Conditions of Sale  
30332 Esperanza, Rancho Santa Margarita, California 92688  
tel 949-546-8000 | fax 949-546-8001 | [www.abracon.com](http://www.abracon.com)

Revised: 05.02.13