

SMD Transient Voltage Suppressor

TV15C5V0-G Thru. TV15C441-G

Working Peak Reverse Voltage: 5.0 - 440 Volts

Power Dissipation: 1500Watts

RoHS Device

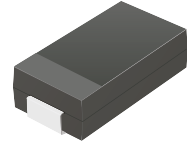

Features

- Glass passivated chip.
- 1500 W peak pulse power capability with a 10/1000 μ s waveform, repetitive rate (duty cycle):0.01%
- Low leakage.
- Uni and Bidirectional unit.
- Excellent clamping capability.
- Very fast response time.

Mechanical Data

- Case: DO-214AB/SMC molded plastic.
- Epoxy: UL 94V-0 rate flame retardant
- Terminals: solderable per MIL-STD-750, method 2026.
- Polarity: Cathode band denoted.
- Weight: Approx. 0.21 grams.

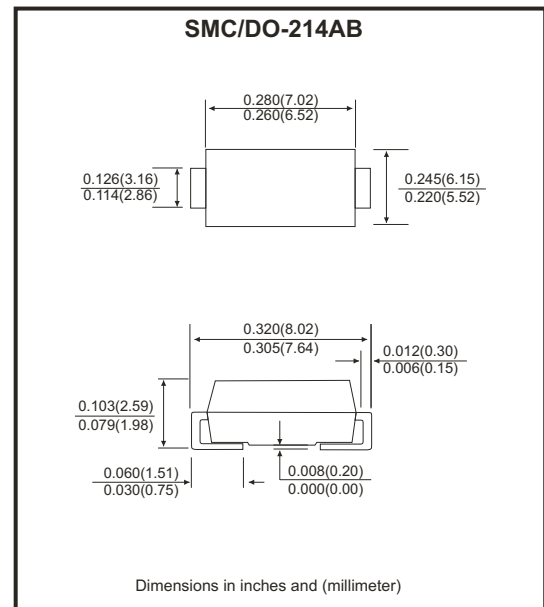

Maximum Ratings and Electrical Characteristics

Rating at 25°C ambient temperature unless otherwise specified.
Single phase, half wave, 60Hz, resistive or inductive load.
For capacitive load, derate current by 20%.

Characteristics	Symbol	Value	Units
Peak power dissipation at 10/1000 μ S waveform (Notes.1)	P _{PPM}	1500	W
Peak pulse current at 10/1000 μ S waveform (Notes.1)	I _{PPM}	See table 1	A
Steady state power dissipation at T _L =75°C	P _D	6.5	W
Peak forward surge current, 8.3ms single half sine-wave superimposed on rated load, uni-directional only (Notes.2)	I _{FSM}	200	A
Maximum instantaneous forward voltage at 100A for uni-directional only (Note.3)	V _F	3.5/5.0	V
Operation junction temperature range	T _J	-55 to +150	°C
Storage temperature range	T _{STG}	-55 to +150	°C

Notes:

1. Non-repetitive current pulse, per Fig. 5 and derated above T_A=25 °C, per Fig. 1
2. Measured on 8.3 ms single half sine-wave or equivalent square wave, duty cycle=4 pulses per minute maximum.
3. V_F<3.5V for devices of V_{BR}<200V and V_F<5.0V for devices of V_{BR}>201V

Ratings and Characteristics Curve (TV15C5V0-G Thru. TV15C441-G)

Fig.1 - Pulse Derating Curve

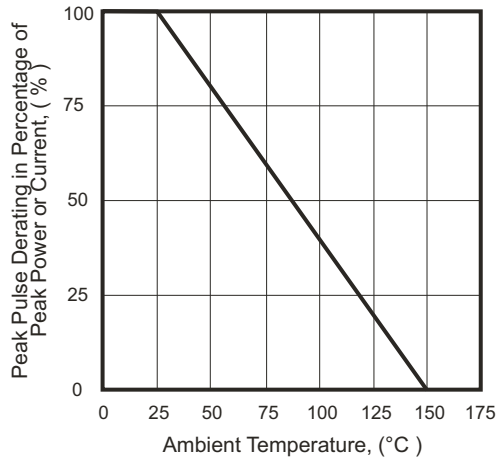

Fig.2 - Max. Non-Repetitive Surge Current

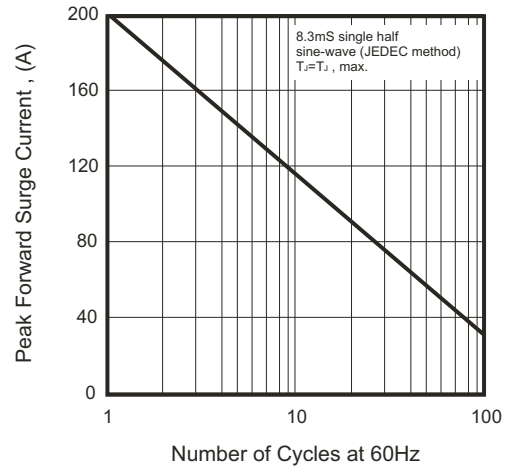

Fig.3 - Steady State Power Derating Curve

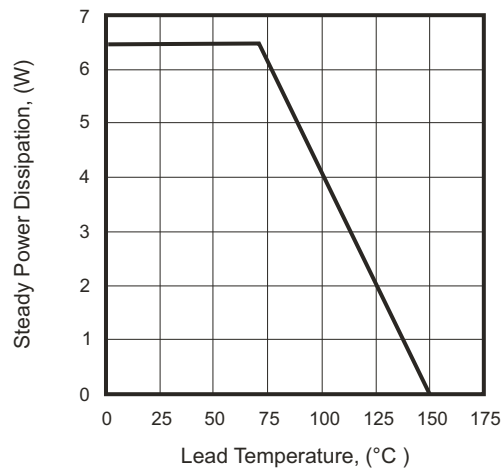

Fig.4 - Peak Pulse Power Rating Curve

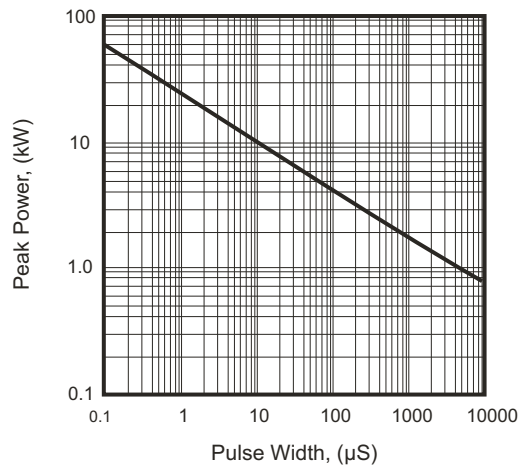

Fig.5- Pulse Waveform

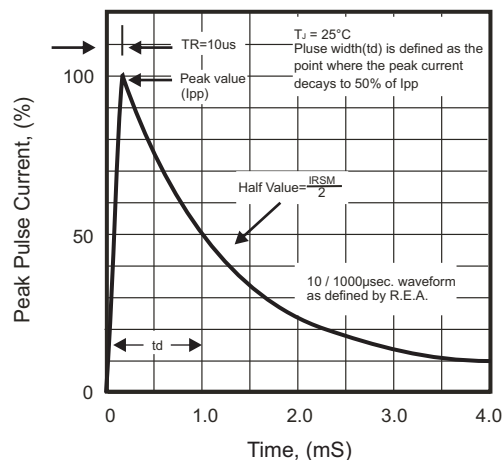
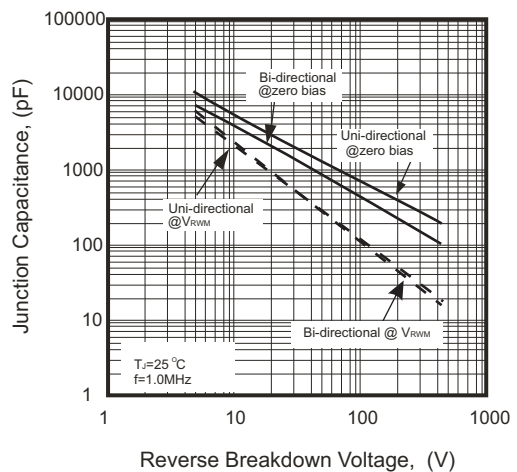

Fig.6 - Typical Junction Capacitance



SMD Transient Voltage Suppressor



Electrical Characteristics (TV15C5V0-G Thru. TV15C441-G)

Part No.	Absolute Maximum Rating(Ta=25°C)					Electrical Characteristic(Ta=25°C)				
	V _{RWM}	V _{BR} Min	V _{BR} Max	I _T	I _{FSM}	MAX V _C	I _R @V _{RWM}	Marking Code		
	(V)	(V)	(V)	(mA)	(A)@8.3ms	(V)	IPP(A)	(μA)	UNI	BI
TV15C5V0J(B)-G	5.00	6.40	7.00	10	200	9.2	163.04	1000	GDE	BDE
TV15C6V0J(B)-G	6.00	6.67	7.37	10	200	10.3	145.63	1000	GDG	BDG
TV15C6V5J(B)-G	6.50	7.22	7.98	10	200	11.2	133.93	500	GDK	BDK
TV15C7V0J(B)-G	7.00	7.78	8.60	10	200	12.0	125.00	200	GDM	BDM
TV15C7V5J(B)-G	7.50	8.33	9.21	1	200	12.9	116.28	100	GDP	BDP
TV15C8V0J(B)-G	8.00	8.89	9.83	1	200	13.6	110.29	50	GDR	BDR
TV15C8V5J(B)-G	8.50	9.44	10.40	1	200	14.4	104.17	20	GDT	BDT
TV15C9V0J(B)-G	9.00	10.00	11.10	1	200	15.4	97.40	10	GDV	BDV
TV15C100J(B)-G	10.0	11.10	12.30	1	200	17.0	88.24	5	GDY	BDY
TV15C110J(B)-G	11.0	12.20	13.50	1	200	18.2	82.42	1	GDZ	BDZ
TV15C120J(B)-G	12.0	13.30	14.70	1	200	19.9	75.38	1	GEE	BEE
TV15C130J(B)-G	13.0	14.40	15.90	1	200	21.5	69.77	1	GEG	BEG
TV15C140J(B)-G	14.0	15.60	17.20	1	200	23.2	64.66	1	GEK	BEK
TV15C150J(B)-G	15.0	16.70	18.50	1	200	24.4	61.48	1	GEM	BEM
TV15C160J(B)-G	16.0	17.80	19.70	1	200	26.0	57.69	1	GEP	BEP
TV15C170J(B)-G	17.0	18.90	20.90	1	200	27.6	54.35	1	GER	BER
TV15C180J(B)-G	18.0	20.00	22.10	1	200	29.2	51.37	1	GET	BET
TV15C190J(B)-G	19.0	21.10	23.30	1	200	30.8	48.73	1	GEB	BEB
TV15C200J(B)-G	20.0	22.20	24.50	1	200	32.4	46.30	1	GEV	BEV
TV15C220J(B)-G	22.0	24.40	26.90	1	200	35.5	42.25	1	GEX	BEX
TV15C240J(B)-G	24.0	26.70	29.50	1	200	38.9	38.56	1	GEZ	BEZ
TV15C260J(B)-G	26.0	28.90	31.90	1	200	42.1	35.63	1	GFE	BFE
TV15C280J(B)-G	28.0	31.10	34.40	1	200	45.4	33.04	1	GFG	BFG
TV15C300J(B)-G	30.0	33.30	36.80	1	200	48.4	30.99	1	GFK	BFK
TV15C330J(B)-G	33.0	36.70	40.60	1	200	53.3	28.14	1	GFM	BFM
TV15C360J(B)-G	36.0	40.00	44.20	1	200	58.1	25.82	1	GFP	BFP
TV15C400J(B)-G	40.0	44.40	49.10	1	200	64.5	23.26	1	GFR	BFR
TV15C430J(B)-G	43.0	47.80	52.80	1	200	69.4	21.61	1	GFT	BFT
TV15C450J(B)-G	45.0	50.00	55.30	1	200	72.7	20.63	1	GFV	BFV
TV15C480J(B)-G	48.0	53.30	58.90	1	200	77.4	19.38	1	GFX	BFX
TV15C510J(B)-G	51.0	56.70	62.70	1	200	82.4	18.20	1	GFZ	BFZ
TV15C540J(B)-G	54.0	60.00	66.30	1	200	87.1	17.22	1	GGE	BGE
TV15C580J(B)-G	58.0	64.40	71.20	1	200	93.6	16.03	1	GGG	BGG
TV15C600J(B)-G	60.0	66.70	73.70	1	200	96.8	15.50	1	GGK	BGK
TV15C640J(B)-G	64.0	71.10	78.60	1	200	103.0	14.56	1	GGM	BGM
TV15C700J(B)-G	70.0	77.80	86.00	1	200	113.0	13.27	1	GGP	BGP
TV15C750J(B)-G	75.0	83.30	92.10	1	200	121.0	12.40	1	GGR	BGR
TV15C780J(B)-G	78.0	86.70	95.80	1	200	126.0	11.90	1	GGT	BGT
TV15C800J(B)-G	80.0	88.80	97.60	1	200	129.6	11.57	1	GGB	BGB
TV15C850J(B)-G	85.0	94.40	104.00	1	200	137.0	10.95	1	GGV	BGV
TV15C900J(B)-G	90.0	100.00	111.00	1	200	146.0	10.27	1	GGX	BGX
TV15C101J(B)-G	100.0	111.00	123.00	1	200	162.0	9.26	1	GGZ	BGZ
TV15C111J(B)-G	110.0	122.00	135.00	1	200	177.0	8.47	1	GHE	BHE
TV15C121J(B)-G	120.0	133.00	147.00	1	200	193.0	7.77	1	GHG	BHG
TV15C131J(B)-G	130.0	144.00	159.00	1	200	209.0	7.18	1	GHK	BHK
TV15C141J(B)-G	140.0	155.00	171.00	1	200	226.8	6.61	1	GHB	BHB
TV15C151J(B)-G	150.0	167.00	185.00	1	200	243.0	6.17	1	GHM	BHM
TV15C161J(B)-G	160.0	178.00	197.00	1	200	259.0	5.79	1	GHP	BHP

Company reserves the right to improve product design , functions and reliability without notice.

REV:E

SMD Transient Voltage Suppressor



Electrical Characteristics (TV15C5V0-G Thru. TV15C441-G)

Part No.	Absolute Maximum Rating(Ta=25°C)					Electrical Characteristic(Ta=25°C)				
	V _{RWM}	V _{BR} Min	V _{BR} Max	I _T	I _{FSM}	MAX V _C	I _R @V _{RWM}	Marking Code		
	(V)	(V)	(V)	(mA)	(A)@8.3ms	(V)	IPP(A)	(uA)	UNI	BI
TV15C171J(B)-G	170.0	189.00	209.00	1	200	275.0	5.45	1	GHR	BHR
TV15C181J(B)-G	180.0	200.00	220.00	1	200	291.6	5.14	1	GHT	BHT
TV15C191J(B)-G	190.0	211.00	232.00	1	200	307.8	4.87	1	GHV	BHV
TV15C201J(B)-G	200.0	224.00	247.00	1	200	324.0	4.60	1	GHW	BHW
TV15C221J(B)-G	220.0	246.00	272.00	1	200	356.0	4.20	1	GHX	BHX
TV15C251J(B)-G	250.0	279.00	309.00	1	200	405.0	3.70	1	GHZ	BHZ
TV15C301J(B)-G	300.0	335.00	371.00	1	200	486.0	3.10	1	GJE	BJE
TV15C351J(B)-G	350.0	391.00	432.00	1	200	567.0	2.60	1	GJG	BJG
TV15C401J(B)-G	400.0	447.00	494.00	1	200	648.0	2.30	1	GJK	BJK
TV15C441J(B)-G	440.0	492.00	543.00	1	200	713.0	2.10	1	GJM	BJM

Note:

- 1) Suffix J denotes 5% tolerance devices,
- 2) Suffix B after part number to specify Bi-directional devices.
- 3) For Bi-Directional devices having V_R of 10 volts and under, the I_R limit is double.

Reel Taping Specification

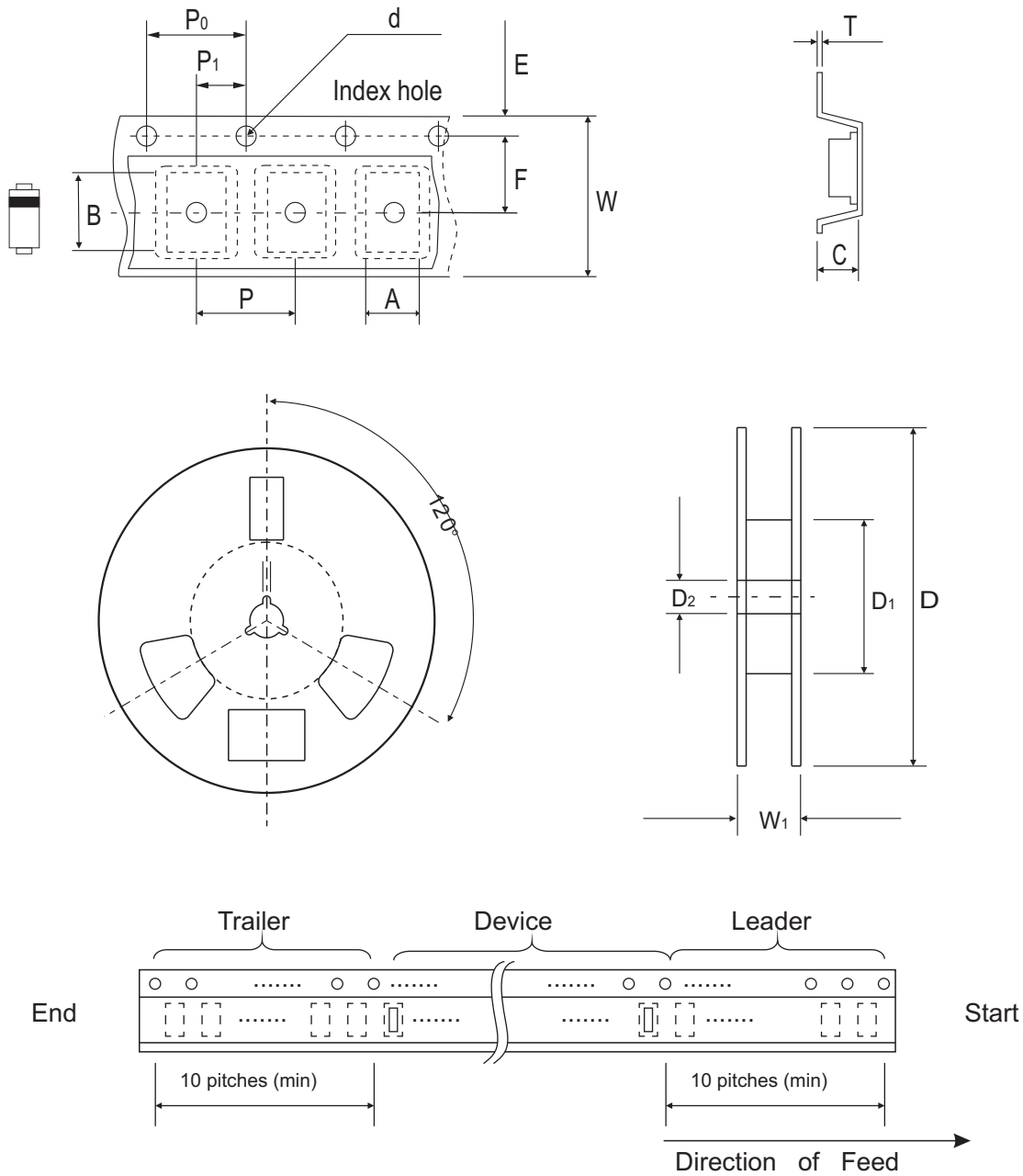

DO-214AB (SMC)	SYMBOL	A	B	C	d	D	D1	D2
	(mm)	6.05 ± 0.10	8.31 ± 0.10	3.29 (max)	1.55 ± 0.10	330.00	50.00 (min)	13.00 ± 0.20
	(inch)	0.238 ± 0.004	0.327 ± 0.004	0.130 (max)	0.061 ± 0.004	13.000	1.969 (min)	0.512 ± 0.008

DO-214AB (SMC)	SYMBOL	E	F	P	P0	P1	W	W1
	(mm)	1.75 ± 0.10	7.50 ± 0.10	8.00 ± 0.10	4.00 ± 0.10	2.00 ± 0.10	16.00 ± 0.30	22.40 (max)
	(inch)	0.069 ± 0.004	0.295 ± 0.004	0.315 ± 0.004	0.157 ± 0.004	0.079 ± 0.004	0.630 ± 0.012	0.882 (max)

Marking Code

1. C: COMCHIP
2. O: Package

O	PKG
A	SMA
B	SMB
C	SMC

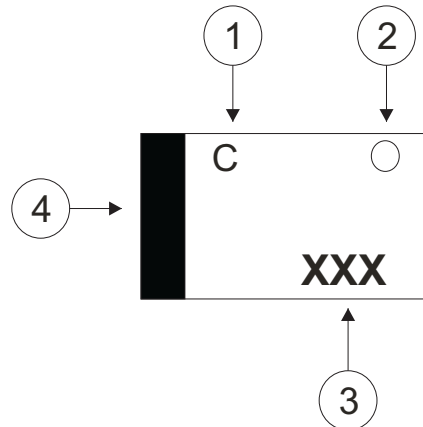

3. XXX: Marking code (see Page.3~5)
4. : Cathod Band

Suggested PAD Layout

SIZE	DO-214AB(SMC)	
	(mm)	(inch)
A	8.13	0.320
B	4.69 MAX	0.185 MAX
C	1.52 MIN	0.06 MIN
D	3.20 MIN	0.126 MIN

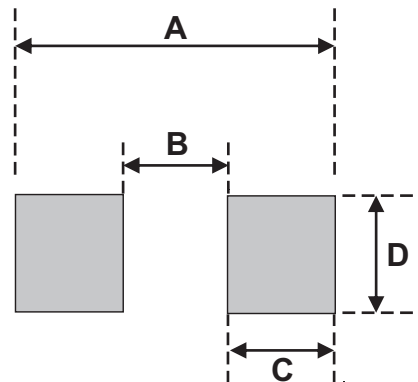

Standard Packaging

Case Type	REEL PACK	
	REEL (pcs)	Reel Size (inch)
DO-214AB (SMC)	3,000	13