

KBP2005G-G Thru. KBP210G-G

Reverse Voltage: 50 to 1000V

Forward Current: 2.0 Amp

RoHS Device

Features

- Ideal for printed circuit board.
- High case dielectric strength.
- High temperature soldering guaranteed
260°C/10 seconds at 5 lbs. (2.3kg) tension.

Mechanical Data

- Case: Molded plastic body over passivated junctions.
- Terminals: Plated leads solderable per MIL-STD-750, Method 2026.
- Epoxy: UL 94V-0 rate flame retardant.
- Polarity: Polarity symbols marked on case.
- Mounting position: Any

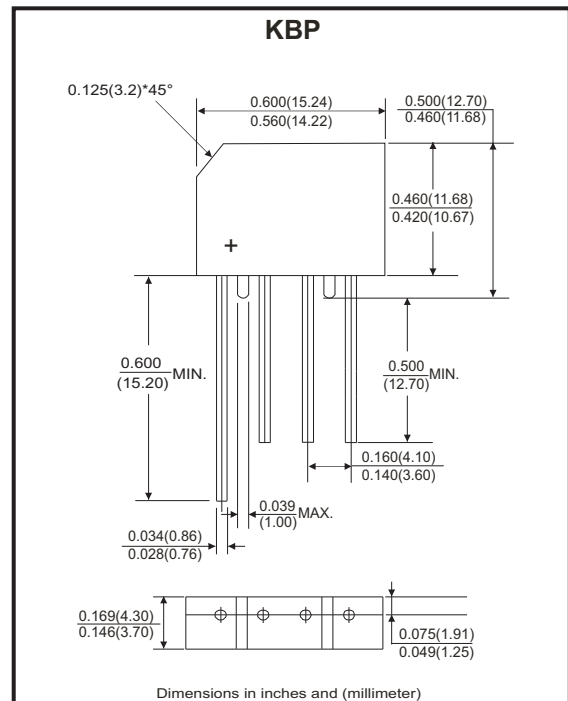

Maximum ratings and electrical characteristics

Rating at 25°C ambient temperature unless otherwise specified.
Single phase, half wave, 60Hz, resistive or inductive load.
For capacitive load, derate current by 20%

Parameter	Symbol	KBP 2005G-G	KBP 201G-G	KBP 202G-G	KBP 204G-G	KBP 206G-G	KBP 208G-G	KBP 210G-G	Unit
Maximum Reverse Peak Repetitive Voltage	V_{RRM}	50	100	200	400	600	800	1000	V
Maximum RMS Voltage	V_{RMS}	35	70	140	280	420	560	700	V
Maximum DC Blocking Voltage	V_{DC}	50	100	200	400	600	800	1000	V
Maximum Average Forward Rectified Output Current at $T_A = 55^\circ\text{C}$	$I_{F(AV)}$	2.0							A
Peak Forward Surge Current, 8.3ms Single Half Sine-Wave Super Imposed On Rated Load @ $T_J = 150^\circ\text{C}$	I_{FSM}	60							A
Maximum Instantaneous Forward Voltage Drop Per Leg at 2.0A	V_F	1.1							V
Maximum DC Reverse Current $T_A = 25^\circ\text{C}$ At Rated DC Blocking Voltage Per Leg $T_A = 125^\circ\text{C}$	I_R	5.0 500							μA
Typical Thermal Resistance Per Leg (Note 1)	$R_{\theta JA}$ $R_{\theta JL}$	30 11							$^\circ\text{C/W}$
Rating For Fusing ($t < 8.3$ ms)	I^2t	15							A^2s
Typical Junction Capacitance Per leg at 4.0A, 1MHz	C_J	25							pF
Operating Junction Storage Temperature Range	T_J, T_{STG}	-55 to +150							$^\circ\text{C}$

Note: 1. Thermal resistance from junction to ambient and from junction to lead mounted on P.C.B. with, 0.47*0.47"(12*12mm) copper pads.

Company reserves the right to improve product design, functions and reliability without notice.

REV:A

Rating and Characteristics Curves (KBP2005G-G Thru. KBP210G-G)

Fig.1 - Derating Curve Output Rectified Current

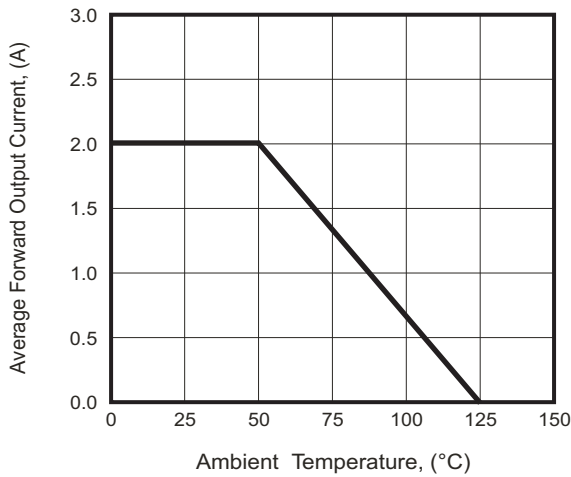

Fig.2 - Non-Recurrent Surge Rating

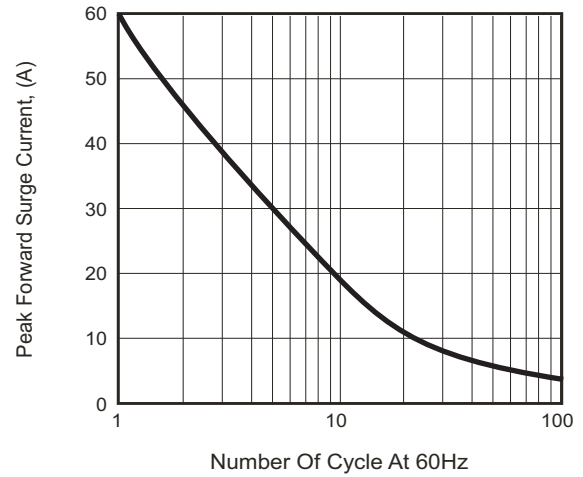

Fig.3 - Typical Forward Characteristics

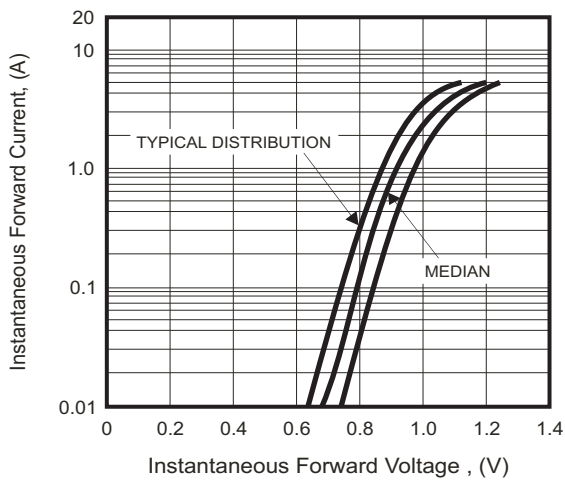
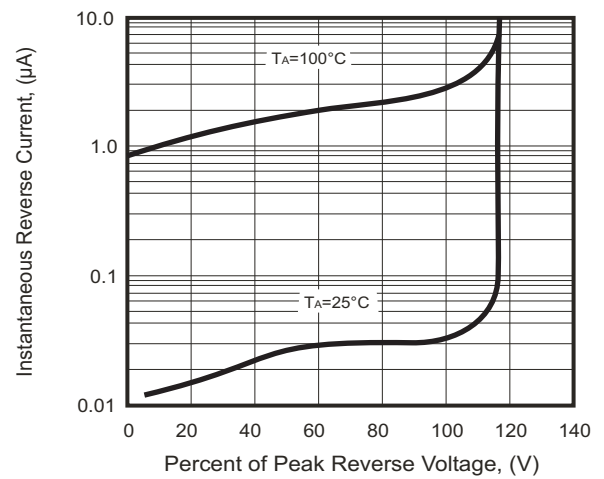
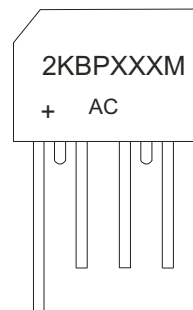

Fig.4 - Typical Reverse Characteristics



Marking Code

Part Number	Marking code
KBP2005G-G	2KBP005M
KBP201G-G	2KBP01M
KBP202G-G	2KBP02M
KBP204G-G	2KBP04M
KBP206G-G	2KBP06M
KBP208G-G	2KBP08M
KBP210G-G	2KBP10M



XX / XXX = Product type marking code

Standard Packaging

Case Type	BULK PACK	
	BOX (pcs)	CARTON (pcs)
KBP	700	7,000