

REVISIONS				
P	LTR	DESCRIPTION	DATE	DWN APVD
C		LOGO CHANGE	07APR2013	PP KZ

MECHANICAL:

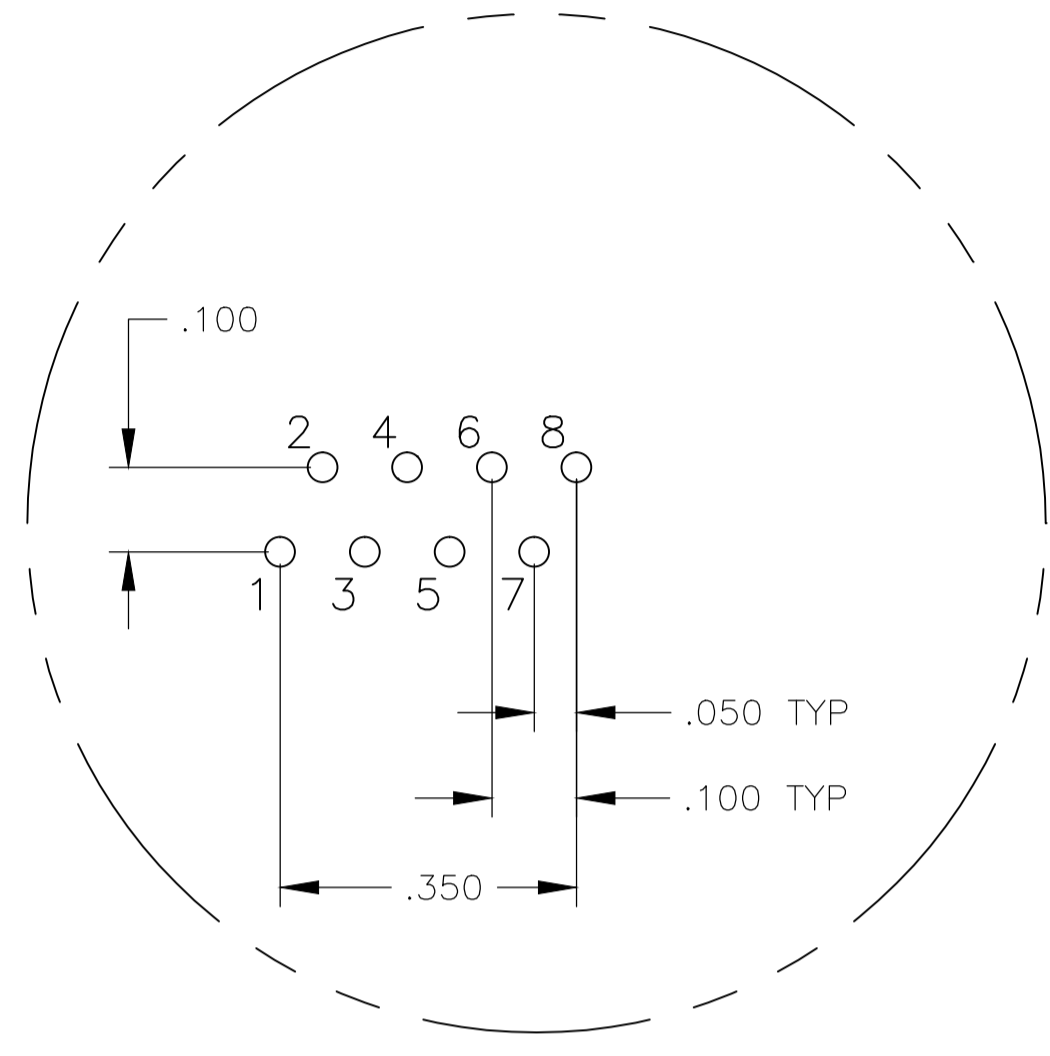
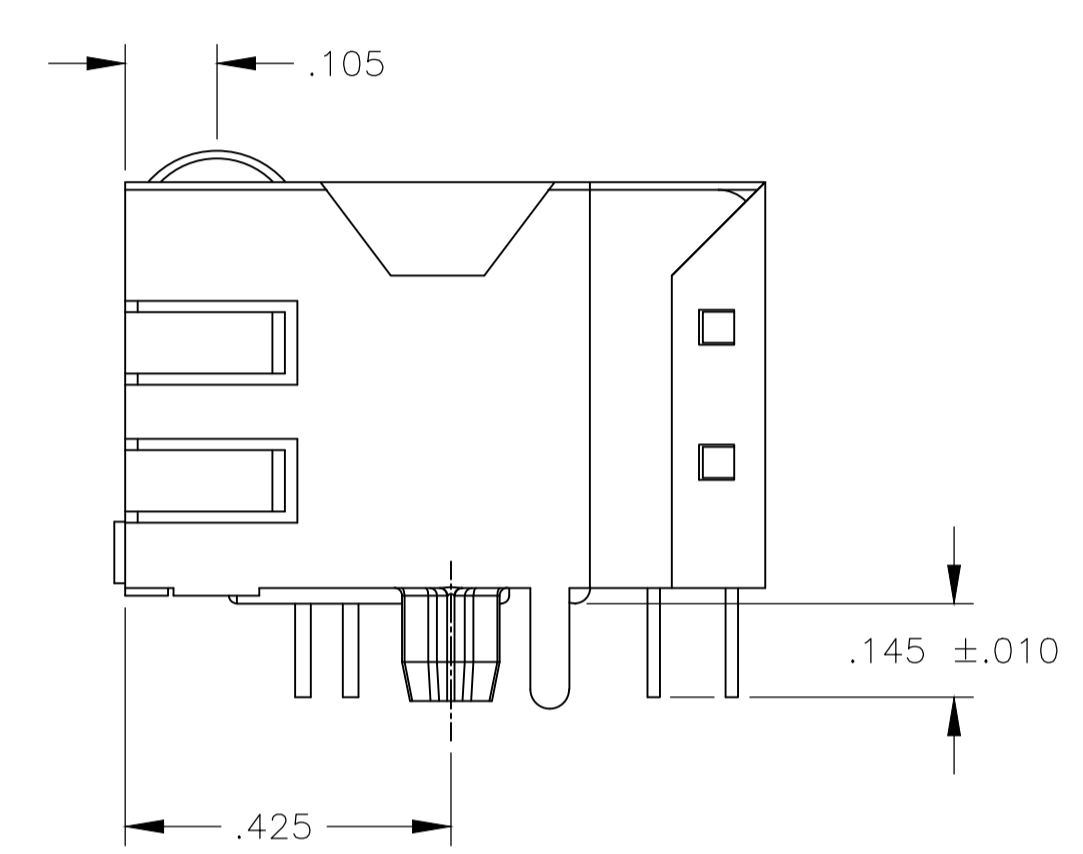
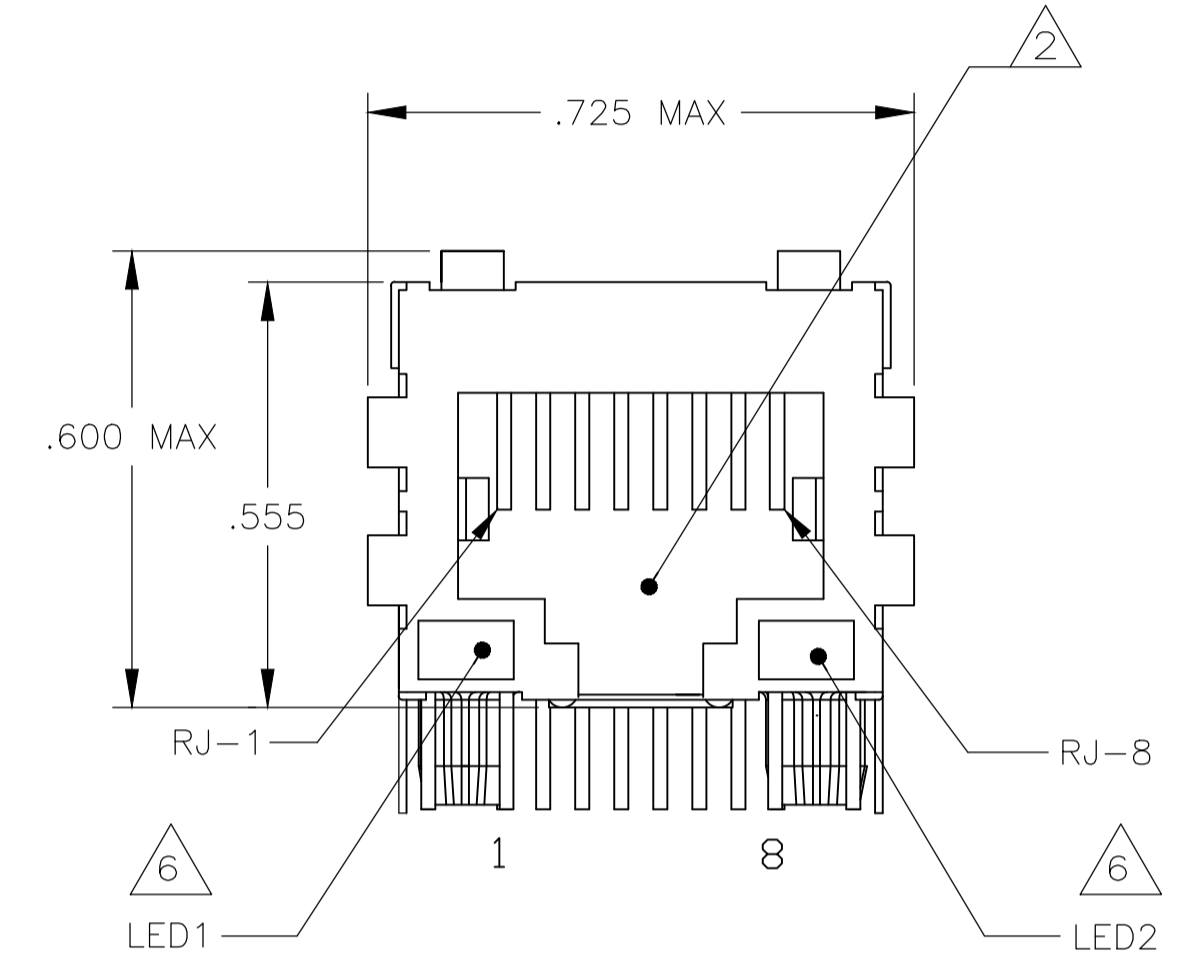
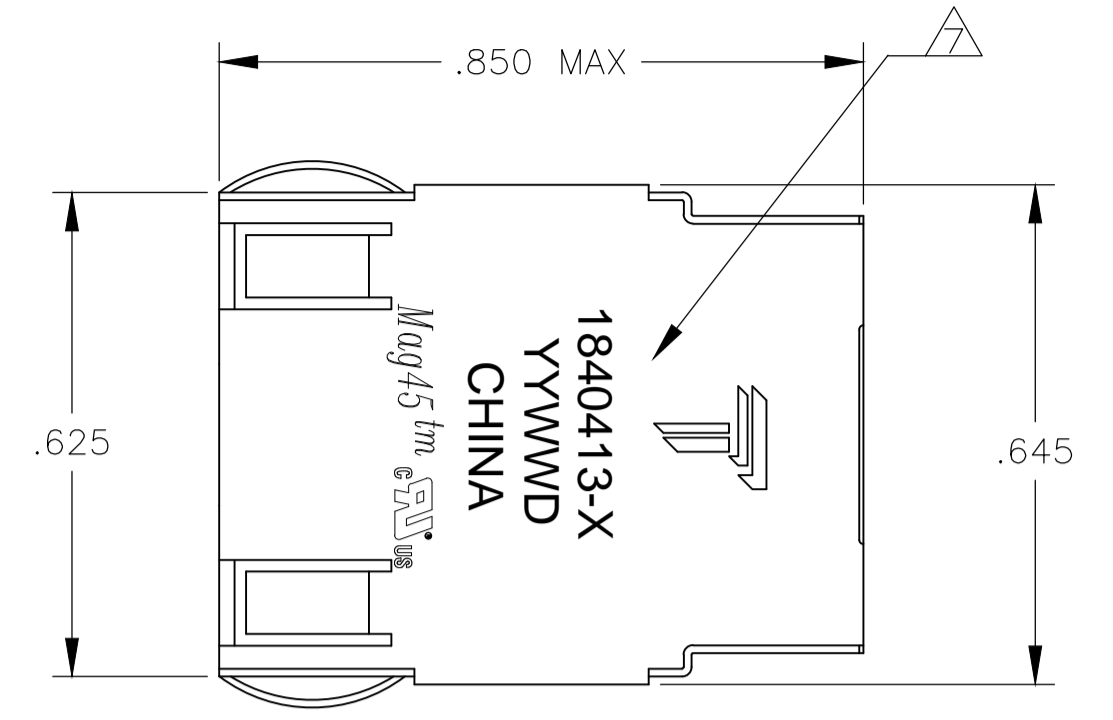

Pin Designations

ELECTRICAL:

326P10 10/100 Base-T CIRCUIT

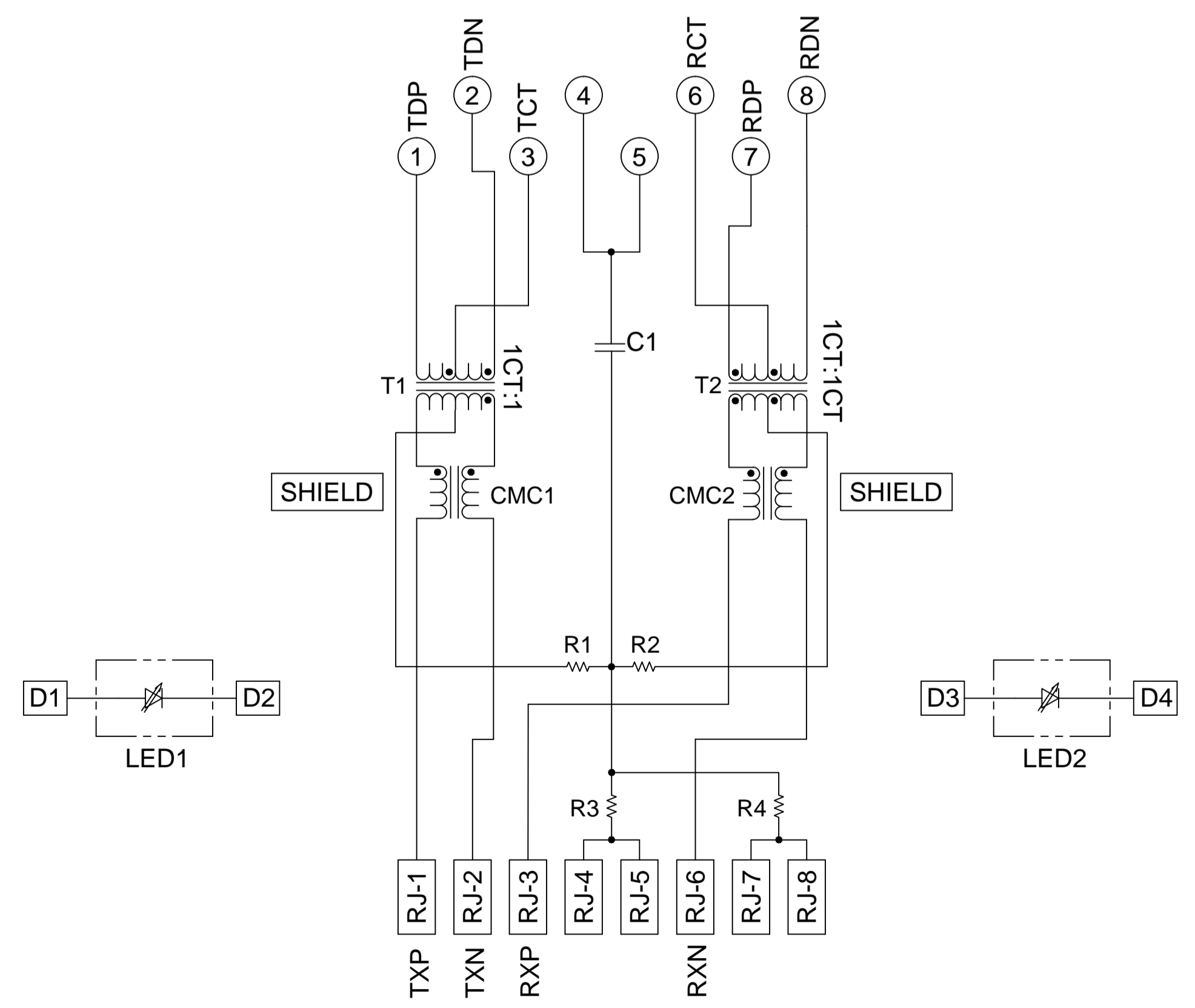

C1=1000 pF, 2kV CAPACITOR
 R1-R4=75 OHMS, 5%, 1/16 W RESISTORS

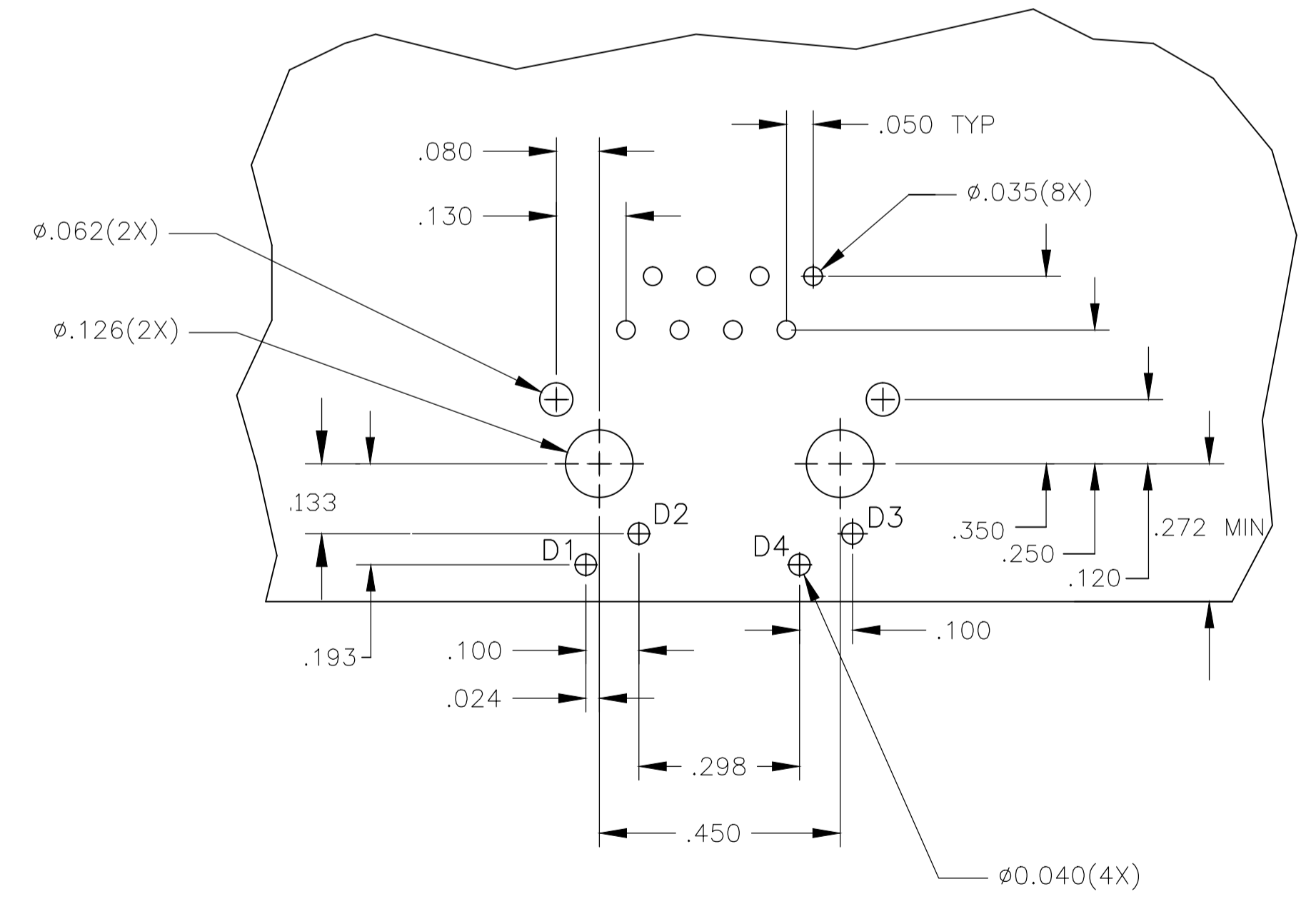

Suggested PCB Layout (Component Side)

MATERIALS:

- HOUSING - THERMOPLASTIC PET POLYESTER FLAMMABILITY RATING UL 94V-0.
- SHIELD - .010" THICK, C26800 BRASS PREPLATED WITH 30uinch MIN SEMI-BRIGHT NICKEL; SOLDER TABS POST-DIPPED WITH 100uinch MIN SAC SOLDER
- MOD JACK CONTACTS - .0157" x .018" THICK, PHOSPHOR BRONZE, 50uinch MIN OVERALL NICKEL UNDERPLATE, WITH SELECT 50uinch MIN HARD GOLD FINISH PLATE.
- LIGHT EMITTING DIODE(LED) - DIFFUSED EPOXY LENS, .020" x .020" CARBON STEEL WIREFRAME LEADS PREPLATED WITH 80 uINCH SILVER OVER 40 uINCH NICKEL UNDERPLATE OVER 40uINCH COPPER UNDERPLATE; POST-PLATED WITH 100 uINCH MIN MATTE TIN AND/OR SAC SOLDER DIP OR PURE TIN SOLDER DIP.

RJ45 JACK CAVITY CONFORMS TO FCC RULES AND REGULATIONS PART 68, SUB PART F.

MAGNETICS

- APPLICATION: 10/100 BASE-T
- IMPEDANCE: 100 OHMS
- TURNS RATIO (CHIP:CABLE): TX = 1:1, RX = 1:1
- OPEN CIRCUIT INDUCTANCE (OCL): 350uH MIN @100kHz, 0.1VRMS, 8mADC BIAS FROM 0°C TO 70°C, TX AND RX
- PERFORMANCE @ 25°C:
 - INSERTION LOSS (IL): 1.1dB MAX FROM 0.5MHz TO 100MHz
 - RETURN LOSS (RL): 18dB MIN FROM 0.5MHz TO 30MHz
 - 18-20LOG(f/30)dB MIN FROM 30.1MHz TO 60MHz
 - 12dB MIN FROM 60.1MHz TO 80MHz
 - CROSSTALK ATTENUATION: 35dB MIN FROM 0.5MHz TO 40MHz
 - 33-20LOG(f/50)dB MIN FROM 40.1MHz TO 100MHz
 - COMMON MODE REJECTION RATIO (CMRR): 30dB MIN FROM 0.5MHz TO 100MHz
- ISOLATION VOLTAGE: COMPLIES WITH IEEE802.3 2002, PARA 23.5.1.1, ITEM b.

OPERATING TEMPERATURE: FROM 0°C TO +70°C.

THE MAGNETICS ARE SYMMETRICAL, AND SUPPORTS AUTO-MDI/MDIX.

LED IS DRIVEN WITH CONSTANT CURRENT AT APPROX 20mA.
 LED COLOR: DOMINANT WAVELENGTH (λ D): GREEN 568 nm TYP. at IF=20mA
 FORWARD VOLTAGE (VF): GREEN 2.2V TYP. at IF=20mA
 DOMINANT WAVELENGTH (λ D): YELLOW 588 nm TYP. at IF=20mA
 FORWARD VOLTAGE (VF): YELLOW 2.1V TYP. at IF=20mA

TRP CONNECTOR LOGO, PART NUMBER, DATE CODE, COUNTRY OF ORIGIN AND AGENCY APPROVAL MARKING IN APPROXIMATE LOCATION SHOWN.

THE PART IS RECOMMENDED FOR WAVE SOLDERING PROCESS, PREHEAT TEMPERATURE IS 120°C TO 160°C, 120 SECONDS TO 180 SECONDS, PEAK WAVE SOLDERING TEMPERATURE IS 260°C MAX, 10 SECONDS MAX.

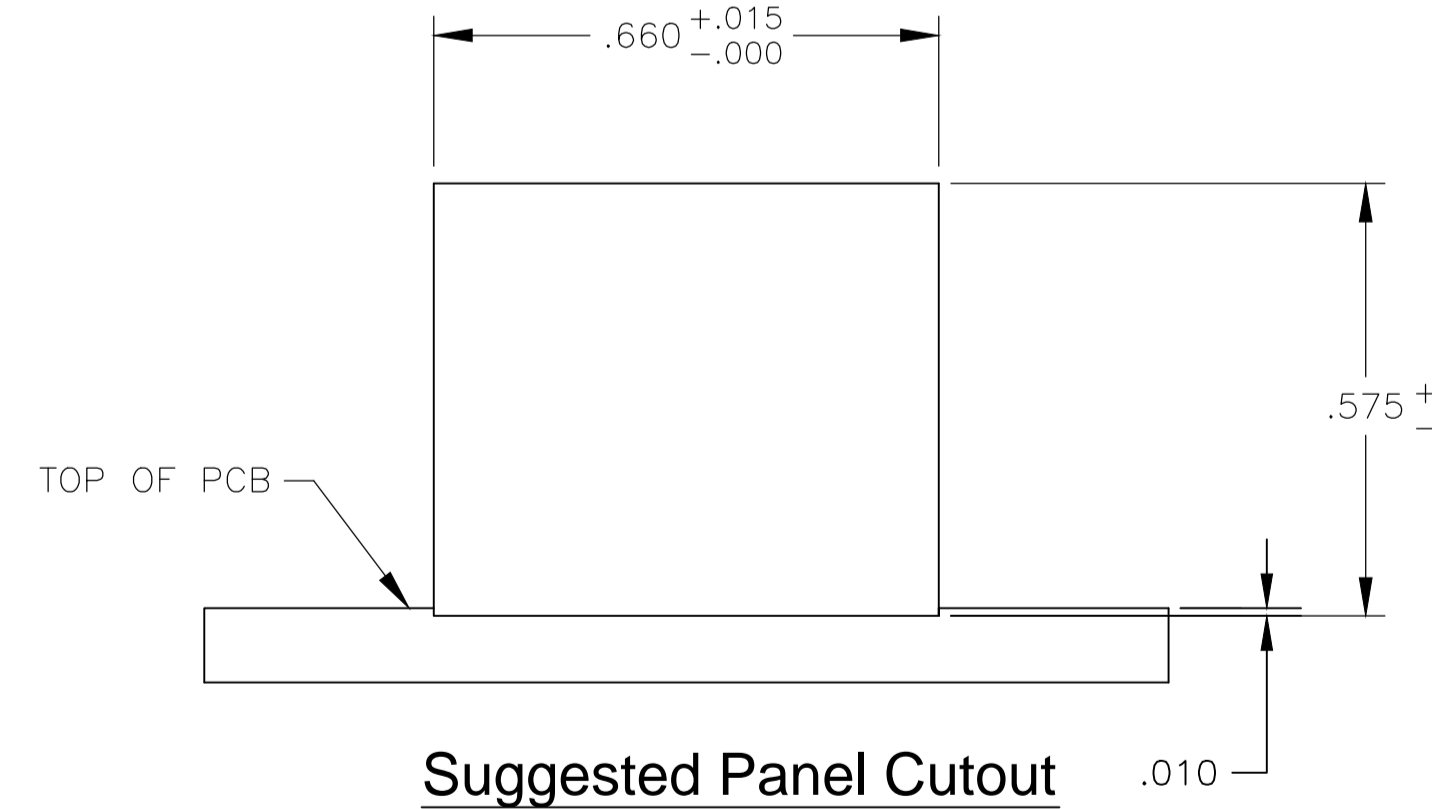

Suggested Panel Cutout

GREEN	YELLOW	1840413-8
LED1	LED2	PART NUMBER

THIS DRAWING IS A CONTROLLED DOCUMENT.		DWN: CLOUD ZENG 4JUL2006	TRP connector Dongguan China
DIMENSIONS: INCHES		CHK: MICHAEL ZHANG 4JUL2006	
TOLERANCES UNLESS OTHERWISE SPECIFIED:		APVD: TEDDY XIONG 4JUL2006	PRODUCT SPEC: 108-2100 APPLICATION SPEC: 1X1 MAG45(TM), 10/100 ETHERNET SCHEMATIC, 326P10 MAGNETIC CIRCUIT, SHIELDED, DECOUPLING CAPACITOR, WITH LEADS
0 PLC ± - 1 PLC ± .010 2 PLC ± .005 3 PLC ± .005 4 PLC ± - ANGLES ± -		NAME: 108-2100 SIZE: A1 CAGE CODE: 00779 DRAWING NO: C=1840413	
MATERIAL		WEIGHT	RESTRICTED TO
CUSTOMER DRAWING		SCALE: NTS	SHEET 1 OF 1 REV C